



Raptor 1100 Wood Chipper

User Manual

[Revision 1.0]

READ THIS MANUAL CAREFULLY BEFORE USE – FAILURE TO DO SO MAY RESULT IN INJURY, PROPERTY DAMAGE AND MAY VOID WARRANTY. • KEEP THIS MANUAL FOR FUTURE REFERENCE. • Products covered by this manual may vary in appearance, assembly, inclusions, specifications, description, and packaging.



The product is NOT supplied with engine oil, although traces of oil from the manufacturing process may be present. It is essential to add adequate engine oil of the correct type to the engine before use.
Failure to add engine oil will void the product warranty.

Safety

Safety messages are designed to alert you to possible dangers or hazards that could cause death, injury or equipment or property damage if not understood or followed. Safety messages have the following symbols:



You **WILL** be **KILLED** or **SERIOUSLY INJURED** if you do not follow instructions.



You **CAN** be **KILLED** or **SERIOUSLY INJURED** if you do not follow instructions.



You **CAN** be **INJURED** if you do not follow instructions or equipment damage may occur.

It is vital that you read and understand this user manual before using the product, including safety warnings, and any assembly and operating instructions. Keep the manual for future reference.

Safety precautions and recommendations detailed here must be fully understood and followed to reduce the risk of injury, fire, explosion, electrical hazard, and/or property damage.

Safety information presented here is generic in nature – some advice may not be applicable to every product. The term "equipment" refers to the product, be it electrical mains powered, battery powered or combustion engine powered.

- **Before Use** - If you are not familiar with the safe operation/handling of the equipment or are in any way unsure of any aspect of suitability or correct use for your application, you should complete training conducted by a person or organization qualified in safe use and operation of this equipment, including fuel/electrical handling and safety.
- Do NOT operate the equipment in flammable or explosive environments, such as in the presence of flammable liquids, gases, or dust. The equipment may create sparks or heat that may ignite flammable substances.
- Keep clear of moving parts.
- Equipment may be a potential source of electric shock or injury if misused.
- Do NOT operate the equipment if it is damaged, malfunctioning or is in an excessively worn state.
- Do NOT allow others to use the equipment unless they have read this manual and are adequately trained.
- Keep packaging away from children - risk of suffocation! Operators must use the equipment correctly. When using the equipment, consider conditions and pay due care to persons and property.

General Work Area Safety

- Work areas should be clean and well lit.
- Do not operate the equipment if bystanders, animals etc are within operating range of the equipment or the general work area.
- If devices are provided for connecting dust extraction / collection facilities, ensure these are connected and used properly. Dust collection can reduce dust-related hazards.

General Personal Safety

- Wear appropriate protective equipment when operating, servicing, or when in the operating area of the equipment to help protect from eye and ear injury, poisoning, burns, cutting and crush injuries. Protective equipment such as safety goggles, respirators, non-slip safety footwear, hard hat, hearing protection etc should be used for appropriate equipment / conditions. Other people nearby should also wear appropriate personal protective equipment. Do not wear loose clothing or jewellery, which can be caught in moving parts. Keep hair and clothing away from the equipment.
- Stay alert and use common sense when operating the equipment. Do not over-reach. Always maintain secure footing and balance.
- Do not use the equipment if tired or under the influence of drugs, alcohol, or medication.
- This equipment is not intended for use by persons with reduced physical, sensory, or mental capabilities.

General Fuel Safety

- Petrol/fuel/gasoline is extremely flammable – keep clear of naked flames or other ignition sources.
- Do not spill fuel. If you spill fuel, wipe it off the equipment immediately – if fuel gets on your clothing, change clothing.
- Do NOT smoke near fuel or when refuelling.
- Always shut off the engine before refuelling.
- Do NOT refuel a hot engine.
- Open the fuel cap carefully to allow any pressure build-up in the tank to release slowly.
- Always refuel in well-ventilated areas.
- Always check for fuel leakage. If fuel leakage is found, do not start, or run the engine until all leaks are fixed.

General Carbon-Monoxide Safety

- Using a combustion engine indoors **CAN KILL IN MINUTES**. Engine exhaust contains carbon-monoxide – a poison you cannot smell or see.
- Use combustion engines **OUTSIDE** only, and far away from windows, doors, and vents.

General Equipment Use and Care

- Keep packaging away from children and pets, potential risk of suffocation or choking.
- The equipment is designed for domestic use only.
- Handle the equipment safely and carefully.
- Before use, inspect the equipment for misalignment or binding of moving parts, loose components, damage, or any other condition that may affect its operation. If damaged, have the equipment repaired by an authorised service centre or technician before use.
- Prevent unintentional starting of the equipment - ensure equipment and power switches are in the OFF position before connecting or moving equipment. Do not carry equipment with hands or fingers touching any controls. Remove any tools or other items that are not a part of the equipment from it before starting or switching on.
- Do not force the equipment. Use the correct equipment for your application. Equipment will perform better and be safer when used within its design and usage parameters.
- Use the equipment and accessories etc. in accordance with these instructions, considering working conditions and the work to be performed. Using the equipment for operations different from those intended could result in hazardous situations.
- Always keep equipment components (engines, hoses, handles, controls, frames, housings, guards etc) and accessories (cutting tools, nozzles, bits etc) properly maintained. Keep the equipment clean and, where applicable, properly lubricated.
- Store the equipment out of reach of children or untrained persons. To avoid burns or fire hazards, let the equipment cool completely before transporting or storing. Never place or store the equipment near flammable materials, combustible gases, or liquids etc.
- The equipment is not weather-proof, and should not be stored in direct sunlight, at high ambient temperatures or locations that are damp or humid.
- Do not clean equipment with solvents, flammable liquids, or harsh abrasives.
- For specific equipment safety use and care, see Equipment Safety.

General Electrical Safety

- Inspect electrical equipment, extension cords, power bars, and electrical fittings for damage or wear before each use. Repair or replace damaged equipment immediately.
- Ensure all power sources conform to equipment voltage requirements and are disconnected before connecting or disconnecting equipment.
- When wiring electrically powered equipment, follow all electrical and safety codes.
- Always use a Residual Current Device (RCD) (GFCI) / Earth Leakage Circuit Breaker / Safety Switch when operating this item (electrical items only).
- High voltage / high current power lines may be present. Use extreme caution to avoid contact or interference with power lines. Electrical shock can be fatal.

General Electrical Safety

- Electrically grounded equipment must have an approved cord and plug and be connected to a grounded electrical outlet.
- Do NOT bypass the ON/OFF switch and operate equipment by connecting and disconnecting the electrical cord.
- Do NOT use equipment that has exposed wiring, damaged switches, covers or guards.
- Do NOT use electrical equipment in wet conditions or in damp locations.
- Do NOT use electrical cords to lift, move or carry equipment.
- Do NOT coil or knot electrical cords, and ensure electrical cords are not trip hazards.

General Service Information

- The equipment must be serviced or repaired at authorised service centres by qualified personnel only.
- Replacement parts must be original equipment manufacturer (OEM) to ensure equipment safety is maintained.
- Do NOT attempt any maintenance or repair work not described in this manual.
- After use, the equipment and components may still be hot – allow the equipment to cool and disconnect spark plugs and/or electrical power sources and/or batteries from it before adjusting, changing accessories, or performing repair or maintenance.
- Do NOT adjust while the equipment is running.
- Perform service-related activities in suitable conditions, such as a workshop.
- Replace worn, damaged or missing warning/safety labels immediately.

Child Choking Hazard!



• WARNING: CHOKING HAZARD - CHILDREN UNDER 8 YRS. CAN CHOKE OR SUFFOCATE ON SMALL PARTS. ADULT SUPERVISION REQUIRED.

- Carefully inspect anything a baby or child could gain access to, including this product & packaging.
- Dangers include anything of a size that could become stuck or lodged in a baby or child's airway.
- Dangers include things like raw, hard fruit and vegetable pieces, large pieces of meat, bones or sausage skins, popcorn, nuts, hard lollies and corn chips, small magnets and batteries, coins, beads, marbles and small uninflated balloons, broken toys and smaller toys, buttons, keys, and coins. But there are also many more.
- Pay particular attention to accessories, nuts, bolts, screws, washers, caps, covers, loose parts, parts that could be removed or break off, pieces of packaging, staples, tape etc.
- In the case of any doubt, secure the item of concern in an appropriate manner, or completely remove the possibility of access by a baby or child.

HAZARDOUS COMPONENTS!

- **BE AWARE THAT THE EQUIPMENT MAY INCLUDE HAZARDOUS COMPONENTS, SUCH AS BLADES, HOT SURFACES AND MOVING PARTS.**
- **MOVING BLADES CAN CAUSE SERIOUS INJURY AND EVEN DEATH IF USED IMPROPERLY OR WITHOUT SUFFICIENT PPE.**
- **DO NOT USE THIS EQUIPMENT ON UNEVEN SURFACES AND ALWAYS MAINTAIN GOOD BALANCE WHEN USING THIS EQUIPMENT. FAILURE TO DO SO MAY CAUSE SERIOUS INJURY.**
- **MAINTAIN A SECURE GRIP OF THE TRIGGER ASSEMBLY AT ALL TIMES.**



Running combustion engines in confined areas CAN KILL IN MINUTES. Engine exhaust fumes contain carbon-monoxide – a deadly gas that you cannot smell or see.



NEVER run a combustion engine in confined areas EVEN IF windows and doors are open. ONLY run petrol engines OUTDOORS and away from doors, windows, and vents.

Do not operate the equipment in hazardous locations, such as where there may be a risk of fire or explosions from flammable liquids, gases or dust.

















Do not operate the equipment in confined areas where exhaust gases, smoke or fumes could reach dangerous concentrations. Do not refuel a combustion engine while it is running or hot. Never smoke while refuelling combustion engines or handling flammable substances.

For generators, the electrical output is potentially lethal and must only be connected to a fixed electrical installation by an appropriately licensed person.

Be aware that the equipment may include hazardous components, such as blades, hot surfaces and moving parts. Handle any flammable substance with extreme caution.

Symbols

The rating plate on your machine may include the following symbols. These indicate important information or safety instructions:

 <p>Read these instructions carefully before use.</p>	 <p>Wear eye protection. Wear hearing protection.</p>	 <p>Wear protective gloves.</p>	 <p>Wear safety footwear</p>	 <p>Do not remove or tamper with guards or safety devices.</p>
 <p>Do not touch hot parts during or after operation. Serious burns may occur.</p>	 <p>No smoking, sparks, or open flames near the machine.</p>	 <p>Never operate the machine in an enclosed area. Risk of carbon monoxide poisoning.</p>	 <p>Keep hands away from moving parts.</p>	 <p>Beware of thrown objects.</p>
 <p>Keep hands away from the hopper inlet during operation.</p>	 <p>Exhaust fumes contain carbon monoxide. Exposure can cause unconsciousness or death. Use only outdoors or in well-ventilated areas.</p>	 <p>Turn off the engine before performing any maintenance.</p>	 <p>Keep a safe distance of at least 24 m.</p>	 <p>Do not chip branches larger than what is stated in the product's online listing.</p>
 <p>Do not allow children to operate the machine.</p>	 <p>Do not refuel while the engine is running.</p>			

Understand Your Machine

- Read this manual and all labels affixed to the machine to understand its limitations and potential hazards. Familiarise yourself thoroughly with the controls and their proper use. Know how to stop the machine and disengage the controls quickly in an emergency.
- Do not attempt to operate the machine until you are confident in how to use and maintain the engine safely, and how to avoid accidental injury or damage.
- If the unit is to be used by someone other than the original purchaser—or if loaned, rented, or sold—always provide this manual and ensure the operator receives appropriate safety training beforehand. The user is responsible for preventing accidents or injuries to themselves, others, and property.
- Do not force the machine. Use the correct tool for your task. The right machine will perform more efficiently and safely at the rate for which it was designed.

Personal Safety

- Never allow children to operate the machine.
- Keep children, pets, and bystanders away from the work area. Stay alert and shut off the machine if anyone enters the area. Supervise children closely at all times.
- Do not operate the machine under the influence of drugs, alcohol, or medication that may impair your ability to operate it safely.
- Dress appropriately: wear heavy long trousers, boots, and gloves. Avoid loose clothing, short pants, or jewellery. Tie back long hair above shoulder level. Loose items can become caught in moving parts.
- Protect your eyes, face, and head from debris. Always wear safety goggles or glasses with side shields.
- Wear appropriate hearing protection.
- Keep hands and feet away from all moving parts and pinch points during operation. Moving parts can cause serious injury.
- Do not touch parts that may be hot after use. Allow all parts to cool before performing maintenance, adjustments, or servicing.
- Stay alert and use common sense during operation.
- Do not overreach. Never operate the machine barefoot or in sandals. Wear protective footwear with good grip to ensure stability on slippery surfaces.
- Maintain proper footing and balance at all times for better control in unexpected situations.

Inspect Your Machine

- Always inspect the machine before use. Ensure all guards are fitted and in good condition. Check that all nuts, bolts, and fasteners are securely tightened.
- Never operate the machine if it is damaged or in poor mechanical condition. Replace any missing, worn, or broken parts before use.
- Inspect for fuel leaks and ensure the machine is in safe working order.
- Do not use the machine if the engine switch fails to turn it on or off. A petrol-powered machine that cannot be controlled via the engine switch is hazardous and must not be used.
- Check that all tools, keys, and adjusting wrenches are removed from the machine area before starting. A tool left attached to a rotating part can cause serious injury.
- Avoid accidental starting. Ensure the engine switch is in the OFF position before transporting or servicing the machine. Servicing or moving the unit with the switch on increases the risk of accidental injury.
- Stop operation immediately if the machine vibrates abnormally. Unusual vibration is a warning sign of a mechanical issue. Turn off the engine and investigate the cause before resuming use.

Engine Safety

- This machine is equipped with an internal combustion engine. Do not use it on or near dry grassland, bushland, or forested areas unless the exhaust system is fitted with a spark arrester that complies with applicable local regulations.
- In some regions, spark arresters are legally required. Similar laws may apply in other areas. If fitted, the spark arrester must be kept in proper working condition by the operator.
- Never start or run the engine in an enclosed space. Exhaust fumes contain carbon monoxide—an odourless, deadly gas. Operate the machine only in well-ventilated outdoor areas.
- Do not modify the engine to exceed its designed speed. The engine's maximum speed is preset by the manufacturer and is within safe operating limits.
- When operating the chipper in dry conditions, keep a Class B fire extinguisher nearby as a precaution.

Fuel Safety

- Petrol is highly flammable, and its vapours can ignite or explode. Follow these precautions to reduce the risk of serious injury:
- Refuel only in a clean, well-ventilated outdoor area using an approved fuel container.
- Never smoke or allow open flames, sparks, or ignition sources near the fuel area or during operation.
- Do not refuel indoors.
- Always stop the engine and let it cool before refuelling. Never remove the fuel cap or add fuel while the engine is running or still hot.
- Never operate the machine if the fuel system has known leaks.
- Loosen the fuel cap slowly to release pressure safely.
- Do not overfill the tank. Leave at least 12 mm (½") of space below the filler neck to allow for fuel expansion.
- Secure all fuel caps tightly and wipe away any spilt fuel before starting the engine.
- If fuel is spilled, do not start the engine. Move the machine away from the spill and wait until the fumes have fully dispersed.
- If fuel contacts your skin or clothing, wash the area thoroughly and change clothes immediately.
- Store fuel in containers specifically approved for petrol.
- Store fuel in a cool, well-ventilated area, away from sparks, flames, or ignition sources.
- Never store fuel or a machine with fuel in the tank inside a building where vapours may reach ignition sources (e.g. water heaters, furnaces, clothes dryers). Allow the engine to cool before storing it in any enclosure.

Specific Safety Rules

Identify hazards and take steps to prevent accidents and reduce risk. Potential hazards include moving parts, ejected debris, the machine's weight, and the surrounding environment.

Before Starting

- Inspect the work area thoroughly. Keep it clean and free from debris to prevent tripping.
- Operate only on flat, level ground.
- Before starting the chipper shredder:
 - Ensure the feed hopper and cutting chamber are empty and free of debris.
 - Check the engine oil level.
 - Confirm all nuts and bolts are securely tightened.
 - Check tyre pressure.

Operation Safety

- Never place any part of your body where it could be harmed during assembly, operation, maintenance, repair, or transport.
- Keep bystanders and pets at least 23 metres (75 feet) away. Stop the machine immediately if anyone approaches.
- Do not put hands, feet, or any body part into the chipper hopper, discharge chute, or near any moving part while the machine is operating.
- Keep the discharge area clear of people, animals, structures, and objects. Debris can be thrown at high speed. Wind may alter the discharge direction—stay aware.
- If you need to push material into the hopper, use a small stick—never your hands.

Raptor 1100 Wood Chipper

- Stand clear of the hopper and discharge chute to avoid injury from kickback or bounced material.
- Do not reach inside the feed hopper beyond the rubber flap while the machine is running.
- Keep flammable materials away from the hot engine.
- Do not tilt the machine while the engine is running.
- Never operate the chipper without the feed hopper and discharge chute securely attached.

Operating Zone

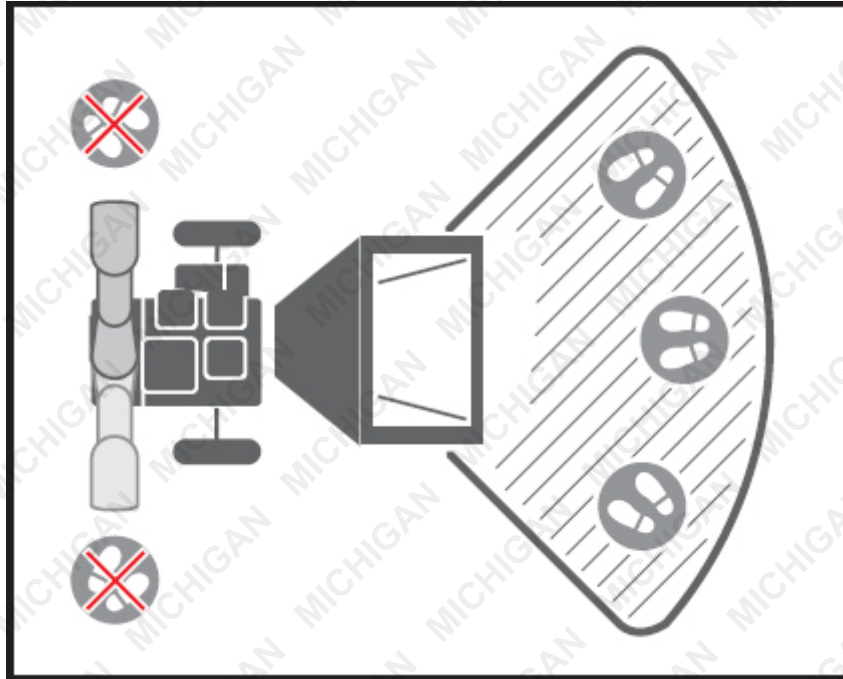

Feeding Materials

- Feed only clean material. Avoid soil, sand, grit, stones, metal, and similar foreign matter, as these will damage the chipper knives. Root balls and dead wood will also dull the blades quickly.
- Avoid feeding pine needles, flax, or cabbage tree leaves—stringy material can wrap around the rotor shaft and work its way into the bearings.
- Short, stubby wood pieces tend to bounce or spin in the hopper. Feed them with longer branches to assist movement through the chute.
- Prune branches to suit the machine's capabilities as you become more familiar with its operation.
- This machine is self-feeding—do not force materials into the blades. Let the machine pull branches through at its own pace.
- Allow the machine to reach full operating speed before feeding the next load.

Unclogging

- Do not let processed material build up in the discharge area. It may block proper ejection and cause dangerous kickback.
- Never attempt to clear blockages while the engine is running. Turn off the engine, wait until all moving parts have stopped, then remove the obstruction.
- After clearing a clog, inspect the machine for damage and ensure all parts are secure before restarting.
- Whenever leaving the operating position or handling built-up debris:
 - Shut off the engine.
 - Switch the engine to OFF.
 - Wait for all parts to stop before proceeding.
- Before opening the cutting disk housing, ensure the engine is off, the disk is at a full stop, and the belt drive is disengaged.

Moving

- Move the machine at least 3 metres away from the refuelling area before starting the engine.
- This chipper shredder is designed for manual movement only. Do not tow it on public roads or highways.
- Always stop the engine before moving the machine. Watch for sharp objects that may damage the tyres.

Machine Use and Care

- Stabilise the machine during maintenance, cleaning, adjustment, or accessory installation to prevent movement.
- Use the correct machine for your application. Forcing the wrong tool compromises safety and efficiency.
- Do not alter the engine governor or run the engine above its designed speed. The governor ensures safe operation.
- Avoid running the engine at high speed when not in use.

Raptor 1100 Wood Chipper

- Keep hands and feet away from rotating parts. The cutting knives can cause severe injury or throw debris.
- Do not touch hot surfaces such as the engine or muffler. Allow the machine to cool before performing maintenance.
- If unusual noise or vibration occurs:
 - Shut off the engine immediately.
 - Disconnect the spark plug wire.
 - Inspect and repair the fault before restarting.
 - Use only manufacturer-approved accessories. Unauthorised parts may cause injury.
- Keep the engine and muffler clear of grass, leaves, oil, and grease to prevent fire hazards.
- Do not hose down the machine. Keep handles dry and clean. Wipe the unit after each use.
- Dispose of fuel, oil, and other waste responsibly, in accordance with local environmental regulations.
- Store the machine safely out of reach of children. Do not allow untrained users to operate it.

Maintaining Your Machine

- Keep plastic and rubber components away from corrosive chemicals.
- Do not cover the machine while the muffler is still hot.
- Do not adjust or tamper with factory-sealed components. Only qualified technicians may service regulated engine parts.
- Check for misalignment, binding, wear, or damage to moving parts. Repair or replace faulty components before use.
- Regular maintenance is critical—many accidents are caused by poorly maintained equipment.

Engine Safety

- Important Safety Information: Most engine-related accidents can be avoided by following the safety instructions in this manual and on the engine itself. Below are common hazards and key ways to protect yourself and others.

Owner Responsibilities

- This engine is designed for safe and reliable operation when used correctly.
- Read and understand this manual before use. Failure to do so may lead to personal injury or equipment damage.
- Know how to stop the engine quickly, and familiarise yourself with all controls before operation.
- Never allow untrained individuals to operate the engine.
- Keep children and pets away from the work area. Children must not operate the engine under any circumstances.

Refuelling Safety

- **⚠️ PETROL IS HIGHLY FLAMMABLE AND ITS VAPOURS CAN EXPLODE.**
- Refuel outdoors in a well-ventilated area, with the engine turned OFF.
- Do not smoke or allow sparks or flames near petrol.
- Always use an approved fuel container for storage.
- If fuel is spilled, wipe the area dry before starting the engine.

Hot Exhaust Warning

- The muffler gets extremely hot during operation and remains hot after shutdown. Do not touch the muffler until it has cooled completely.
- Allow the engine to cool before storing indoors.
- Maintain at least 1 metre (3 feet) of clearance from walls and other objects to ensure adequate ventilation and prevent fire hazards.
- Keep flammable materials away from the engine at all times.

Carbon Monoxide Hazard

- **⚠️ EXHAUST GASES CONTAIN POISONOUS CARBON MONOXIDE.**
- Do not inhale exhaust fumes.
- Never run the engine indoors or in an enclosed, unventilated area.

Recycling and Disposal























This symbol indicates that the product must not be disposed of with regular household waste. To help prevent potential harm to the environment or human health from improper disposal, recycle it responsibly to support the sustainable reuse of resources.

To dispose of your used device, use appropriate return or collection systems, or consult your local council or retailer for environmentally safe recycling options.

DANGER	
<p>Using an engine or wood/charcoal/gas fuelled appliance indoors CAN KILL YOU IN MINUTES. Engine exhaust and wood/charcoal/gas fumes contain carbon monoxide. This is a poison you cannot see or smell.</p>	
<p>NEVER use inside a building, home, garage, boat, caravan or tent EVEN IF doors and windows are open.</p>	<p>Only use OUTSIDE and far away from windows, doors, and vents.</p>
<p>Avoid other hazards - READ MANUAL BEFORE USE.</p>	
<p>GENERAL:</p> <ul style="list-style-type: none"> • Do not operate in a hazardous location. Such areas include where there is a risk of explosion of petrol fumes, leaking gas or explosive dusts. • Do not operate in a confined area where exhaust gases or wood/charcoal/gas fumes could reach dangerous concentrations. <p>PRODUCTS FEATURING AN ENGINE</p> <ul style="list-style-type: none"> • Follow all warnings in the section titled "GENERAL". • Explosion hazard - never smoke while refuelling. • Take care not to spill fuel. When refuelling the engine, ensure that the engine has been allowed to cool. Prevent spilling of fuel as this may also ignite with a hot engine. • Never refuel while engine is running. <p>GENERATORS</p> <ul style="list-style-type: none"> • Follow all warnings in the sections titled "GENERAL" and "PRODUCTS FEATURING AN ENGINE". • The output of this generator is potentially lethal. The generator should not be connected to a fixed electrical installation except by an appropriately licensed person. • Not weatherproof – protect your machine. This machine is not weatherproof and should not be exposed to direct sunlight, high ambient temperature, damp conditions, wet conditions or high humidity conditions. 	

Safety Symbols

The product may have safety warning labels attached to it, explained below. Understand the symbols on your product and their meanings. If any stickers become unreadable, unattached etc., replace them.

 <p>Flammable Material Hazard Flammable liquids, gases, or substances etc may present. Avoid ignition sources and open flames. Danger of fire.</p>	 <p>Read User Manual Read and fully understand product safety warnings, operation, procedures etc before using the product.</p>	 <p>Use Hand Protection Wear appropriate hand protection and take due care as the product or use of the product may present hand hazards.</p>	 <p>Carbon-Monoxide Hazard Do not use the product in confined areas or without adequate ventilation. Carbon-monoxide poisoning can be fatal.</p>
 <p>Electrocution / Electrical Shock Hazard High voltage or high current electricity may be present or required by the product. Take due care when handling electrical products, cables, plugs and leads. Electrical shock can be fatal.</p>	 <p>Toxic Fumes / Dust Hazard Using the product or by-products from use may produce fumes, smoke or particles that could be harmful if inhaled. Wear appropriate breathing protection and have adequate ventilation.</p>	 <p>Explosive Material Hazard Combustible liquids, gases, or substances etc may be present. Avoid ignition sources and open flames. Danger of explosion.</p>	 <p>Cutting / Amputation Hazard The product may have blades, edges or mechanical devices that can cause severe cut injury to fingers, limbs etc. Take due care when handling and using the product.</p>
 <p>Crush Hazard The product may have blades, edges or mechanical devices that can cause severe crush injury to fingers, limbs etc. Take due care when handling and using the product.</p>	 <p>Single Operator Only The product must be operated by a single person only. More than one person operating the product may introduce additional hazards.</p>	 <p>Use Face Protection Wear appropriate full-face protection and take due care as the product or use of the product may present face and eye hazards.</p>	 <p>Use Foot Protection Wear appropriate foot protection and take due care as the product or use of the product may present foot hazards.</p>
 <p>Use Eye / Ear / Head Protection Wear appropriate eye and / or ear and / or head protection and take due care as the product or use of the product may present eye, hearing, and head hazards.</p>	 <p>Running Hazard Do not run on or near the product as doing so may present a fall hazard.</p>	 <p>Diving Hazard Do not dive into the product as doing so may present a neck / head injury hazard.</p>	 <p>Adult Supervision Required Always supervise children and other users of a product to prevent drowning or injury.</p>
 <p>Skin Penetration / Puncture Hazard The product may produce pressure, emit liquids or objects that can cause severe injury to fingers, limbs, blood etc. Take due care when handling and using the product.</p>	 <p>Hot Surface Hazard Be aware that the product may produce high temperatures and hot surfaces that can cause burn injuries.</p>	 <p>Flying Debris Hazard Be aware that the product or use of the product may present hazards produced by flying debris. Wear appropriate clothing and protective devices.</p>	 <p>Moving Parts Hazard Be aware that the product contains or uses mechanical devices that move or rotate. Always wait for moving parts to stop fully before handling the product, adjusting, maintenance etc.</p>















 <p>Carbon-Monoxide Hazard Do not use the product in confined areas or without adequate ventilation. Carbon-monoxide poisoning can be fatal.</p>	 <p>Pull Hazard Be aware that the product contains or uses mechanical devices that can pull in objects and can cause severe injury to fingers, limbs etc. Take due care when handling and using the product.</p>	 <p>Slope / Fall Injury Hazard Be aware that using the product on sloping surfaces or in slippery conditions may present additional dangers from falls and contact with blades, moving parts, hot surfaces etc.</p>	 <p>"Slam Dunk" Warning Do NOT attempt "slam dunk" manoeuvres as this may result in severe injury due to falling, product breakage or collapse etc.</p>
 <p>Electrocution / Electrical Shock Hazard - Outdoor High voltage or high current electricity may be present or required by the product. Do NOT use in rain, damp, or wet conditions. Electrical shock can be fatal.</p>	 <p>Electrocution / Electrical Shock Hazard - Disconnect High voltage or high current electricity may be present or required by the product. Always disconnect the product from the electrical supply before handling the product, adjusting, maintenance etc.</p>	 <p>Power Line Electrocution Hazard High voltage / high current power lines may be present. Use extreme caution to avoid contact or interference with power lines. Electrical shock can be fatal.</p>	 <p>"Kick-Back" Hazard High level of "kick-back" hazard that can cause the machine to suddenly rotate towards operator. Kick-back injury can be fatal.</p>
 <p>Winch Operator Position Hazard Do NOT stand between winch and load. Do NOT use winch to move people.</p>	 <p>Winch Lift Hazard Do NOT LIFT load vertically. Use machine to PULL only.</p>	 <p>Cable Hazard Ensure that load bearing cable is not kinked or knotted.</p>	 <p>Winch Cable Hazard Ensure that there is a minimum number of cable coils on winching mechanism.</p>
 <p>Winch Hook Hazard Carry hook to load – do NOT throw or run.</p>	 <p>Flash / Blinding Hazard Wear appropriate eye protection for welding. Direct exposure to weld arcs may cause permanent eye injury.</p>	 <p>Laser Hazard Laser may be in use – do NOT look directly at laser or allow others to.</p>	 <p>Choking Hazard Children under 8 yrs. Can choke or suffocate on small parts. Adult supervision required.</p>



Table of Contents

Safety 2

 Safety Symbols 9

Contents Supplied 13

Assembly 15

 Support Leg 15

 Wheels 16

 Hopper 19

 Discharge Chute 21

 Emergency Stop Handle 21

 Feed Tray 22

 Emergency Stop Switch 22

 Guard Net for Discharge Outlet 23

 Emergency Stop Wire Connection 24

Know Your Wood Chipper 25

Wood Chipper Operation 27

 Adding Oil to the Engine 27

 Adding Petrol to the Engine 27

 Starting the Engine 28

 Operating the Chipper Shredder 28

 Emergency Stop 30

 Idle Speed 31

 Stopping the Engine 31

 Transporting 31

Wood Chipper Maintenance 32

 Preventive Maintenance 32

 Regular Maintenance Checklist 33

 Greasing the Outside Bearing 33

 Greasing the Inside Bearing 34

 Knife and Wear Plate Inspection 36

 Knife Removal and Replacement 36

 Wear Plate Removal and Replacement 38

 V-Belt Inspection and Adjustment 41

 V-Belt Tensioning 42

 V-Belt Replacement 44

 Lubrication 45

Engine Maintenance 46

 The Importance of Maintenance 46

 Engine Maintenance Safety 46



Raptor 1100 Wood Chipper







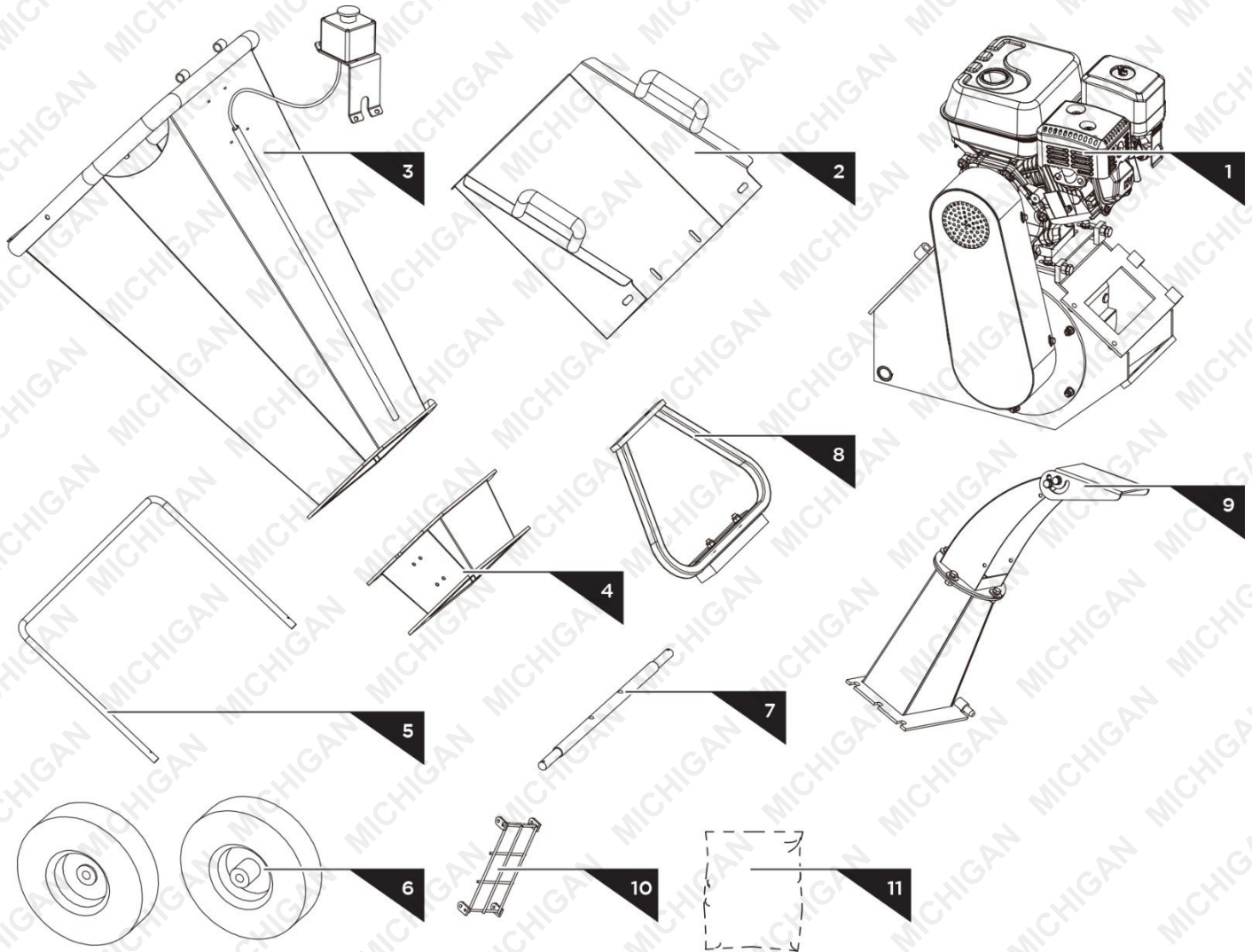



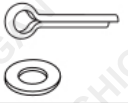

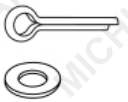
Engine Maintenance Schedule.....	47
Refueling.....	48
Engine Oil Level Check.....	49
Engine Oil Change.....	50
Reduction Gear Oil.....	51
Engine Oil Recommendations.....	51
Air Filter Inspection.....	52
Air Cleaner Service.....	53
Sediment Cup Cleaning.....	55
Spark Plug Service.....	56
Idle Speed Adjustment.....	57
Spark Arrester Service (Optional Equipment).....	57
Storage.....	59
Troubleshooting.....	60
Specifications.....	62

Contents Supplied

The wood chipper is partially assembled and shipped in secure packaging. After unpacking, ensure all components listed below are included.



No.	Name
1	Main Machine
2	Feed Tray
3	Feed Hopper – Upper
4	Feed Hopper – Lower
5	Emergency Stop Handle
6	Wheels
7	Wheel Shaft
8	Support Leg
9	Discharge Chute
10	Guard Net for Discharge Outlet
11	Hardware bag (see image below for contents)

	M10 × 35	× 2	A
	3 × 35	× 1	B
	Ø16	× 1	
	M8 × 50	× 2	C
	3 × 35	× 1	D
	Ø16	× 1	
	M8 × 25	× 4	E
	M8	× 2	F
	M8	× 2	G
	3 × 35	× 2	H
	M8 × 45	× 2	I
	M8 × 20	× 3	
	M6 × 14	× 4	J
	M6 × 14	× 4	K

Assembly

Support Leg

1. Align the two holes in the support leg with the corresponding holes in the drive housing weldment.
2. Secure the support leg using:
 - 2 × M10 × 35 mm bolts
 - 4 × flat washers
 - 2 × spring washers
 - 2 × nuts

Ensure all fasteners are tightened securely.

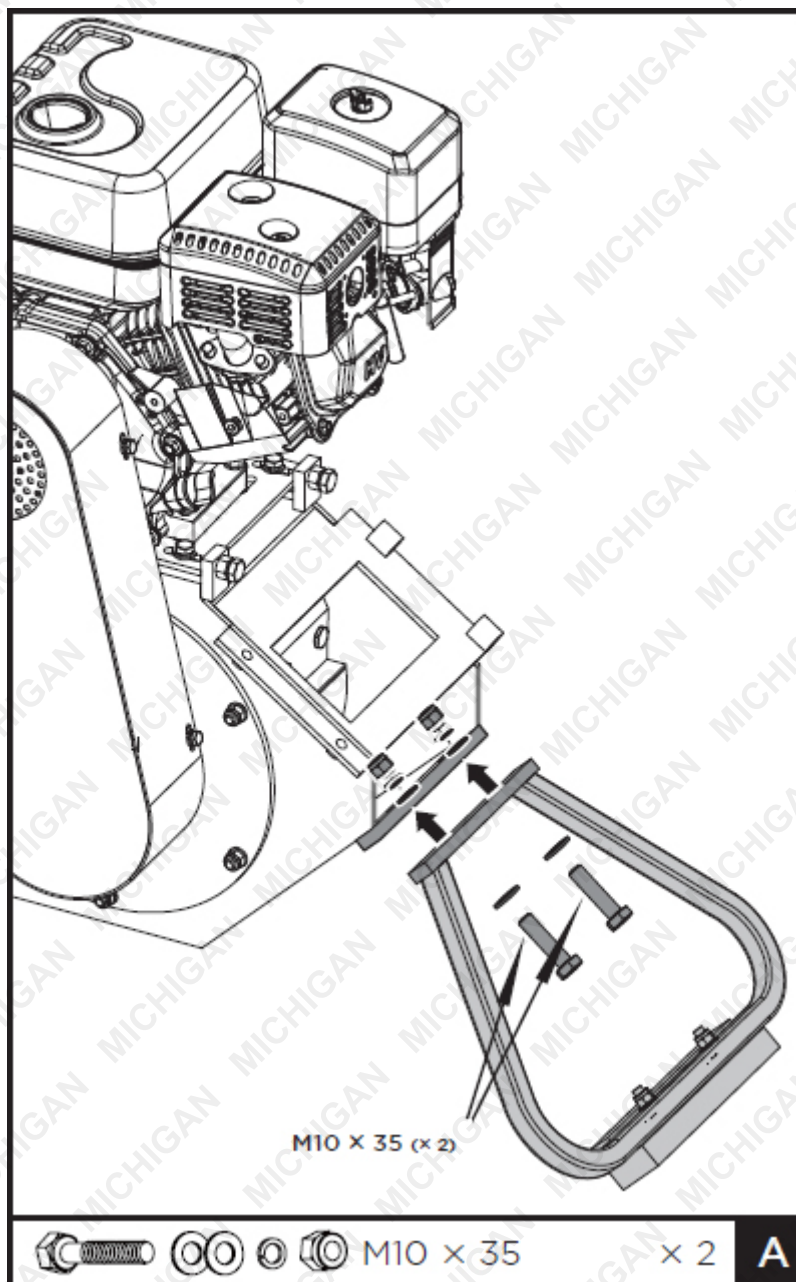

Wheels

1. Install the first wheel:

- a. Slide one wheel onto the axle.
- b. Place a flat washer against the wheel.
- c. Insert a cotter pin through the axle hole and bend the ends to secure it.

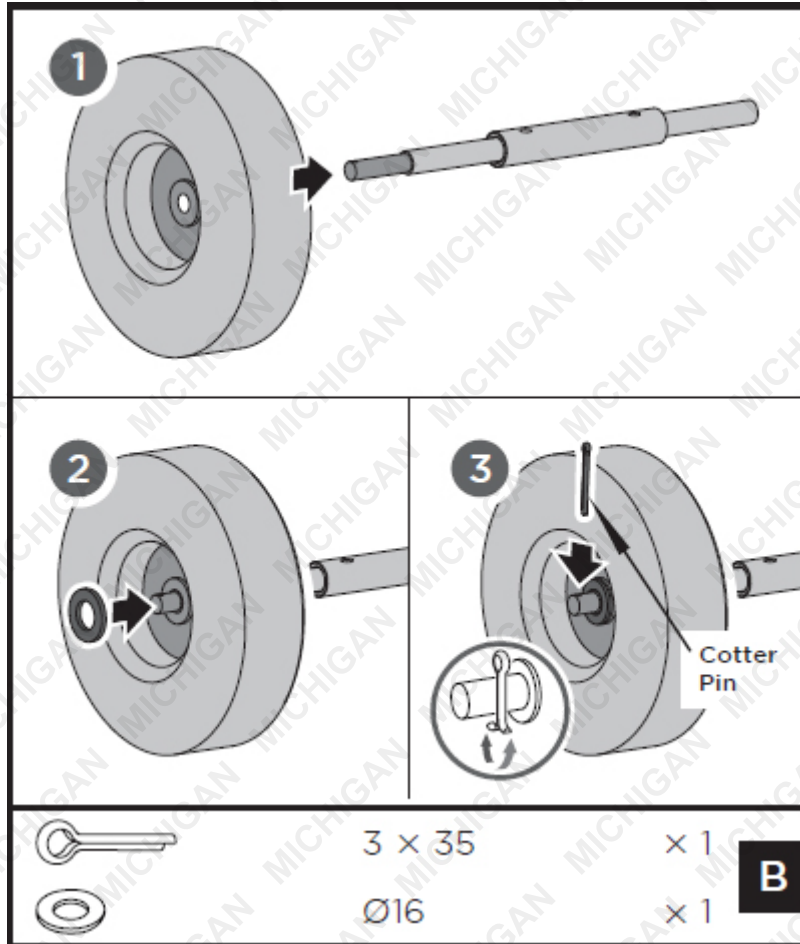

2. Attach the axle assembly:

- a. Insert the wheel axle into the axle sleeve.
- b. Align the holes in the axle and sleeve.
- c. Secure using:
 - 2 × M8 × 50 mm bolts
 - 4 × flat washers
 - 2 × spring washers
 - 2 × nuts

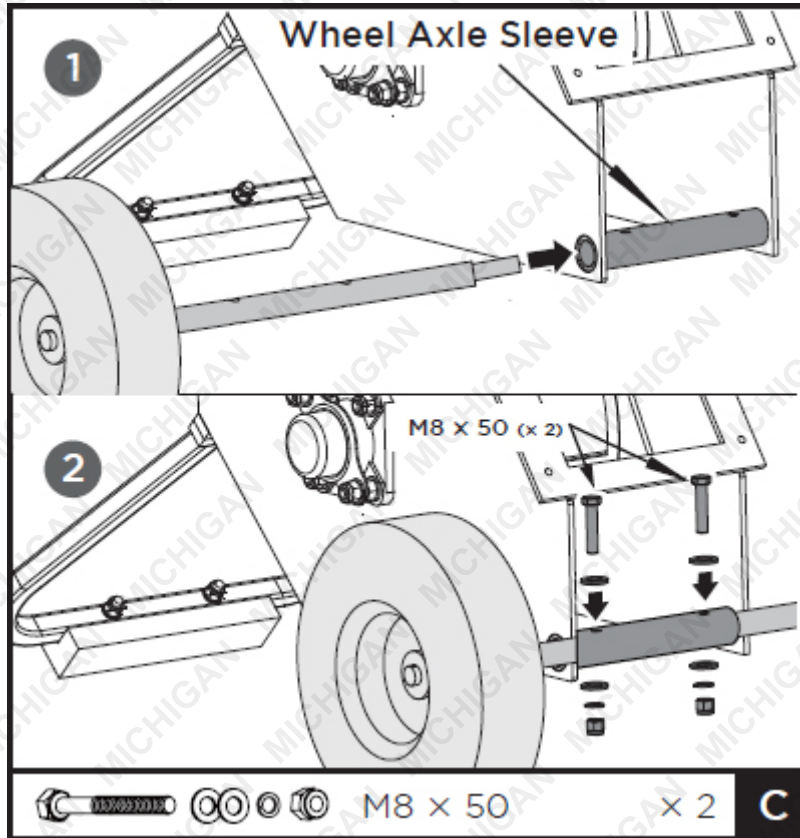

3. Install the second wheel:

- a. Slide the remaining wheel onto the axle.
- b. Place a flat washer against the wheel.
- c. Insert a cotter pin through the axle hole and bend the ends to secure it.

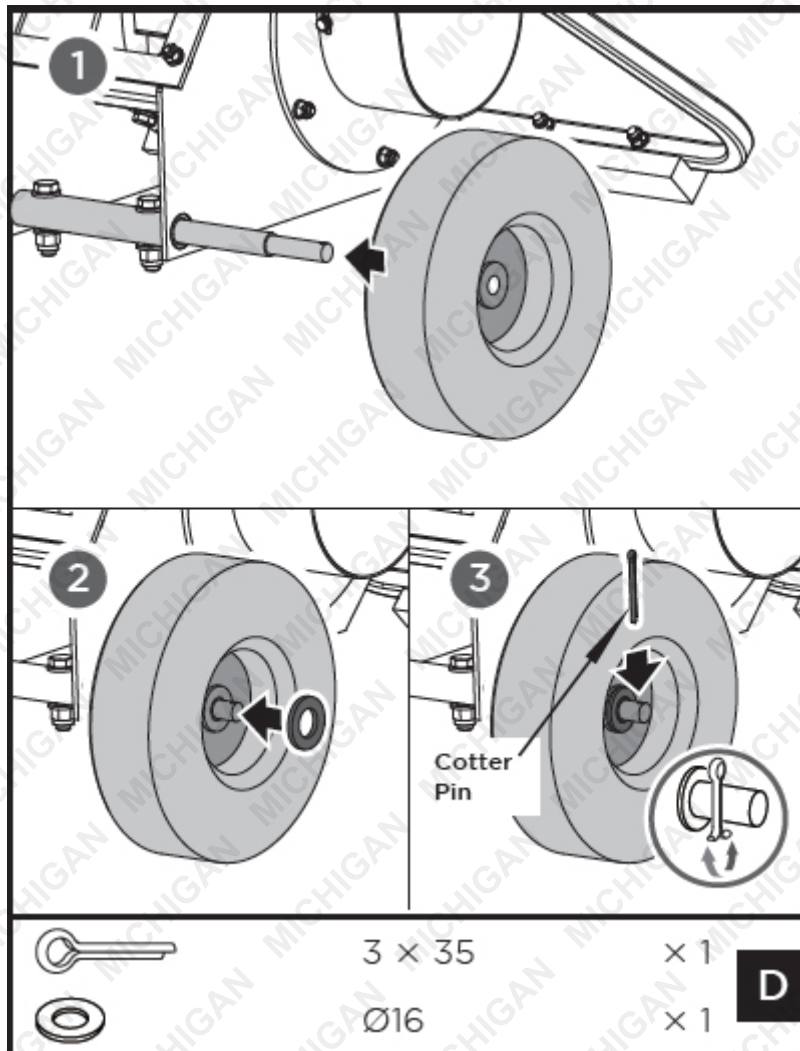

Hopper

1. Install the lower feed hopper:

- a. Position the lower feed hopper onto the machine.
- b. Secure it using the appropriate bolts, washers, and nuts.

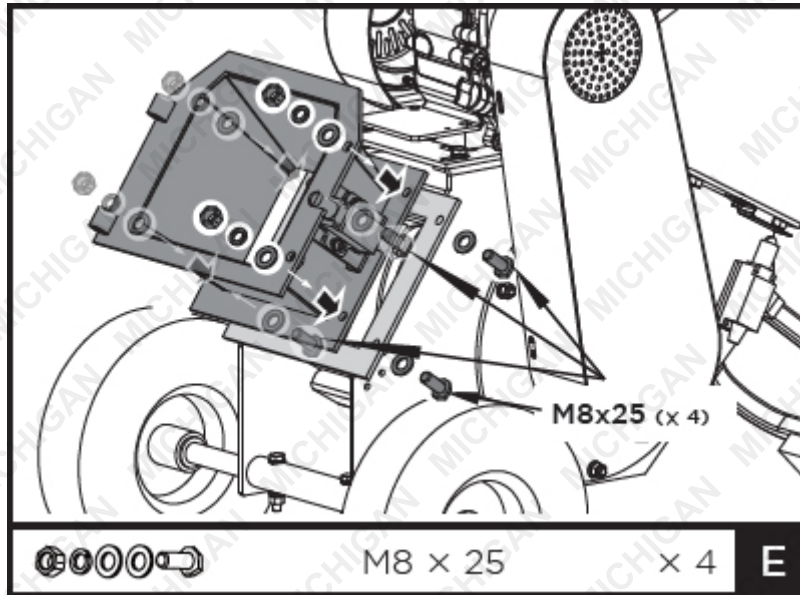

2. **Attach the upper feed hopper:**

- a. Slide the hinge pins of the upper feed hopper fully into the bushings on the lower hopper.
- b. Close the upper hopper onto the lower hopper and secure with washers and nuts.

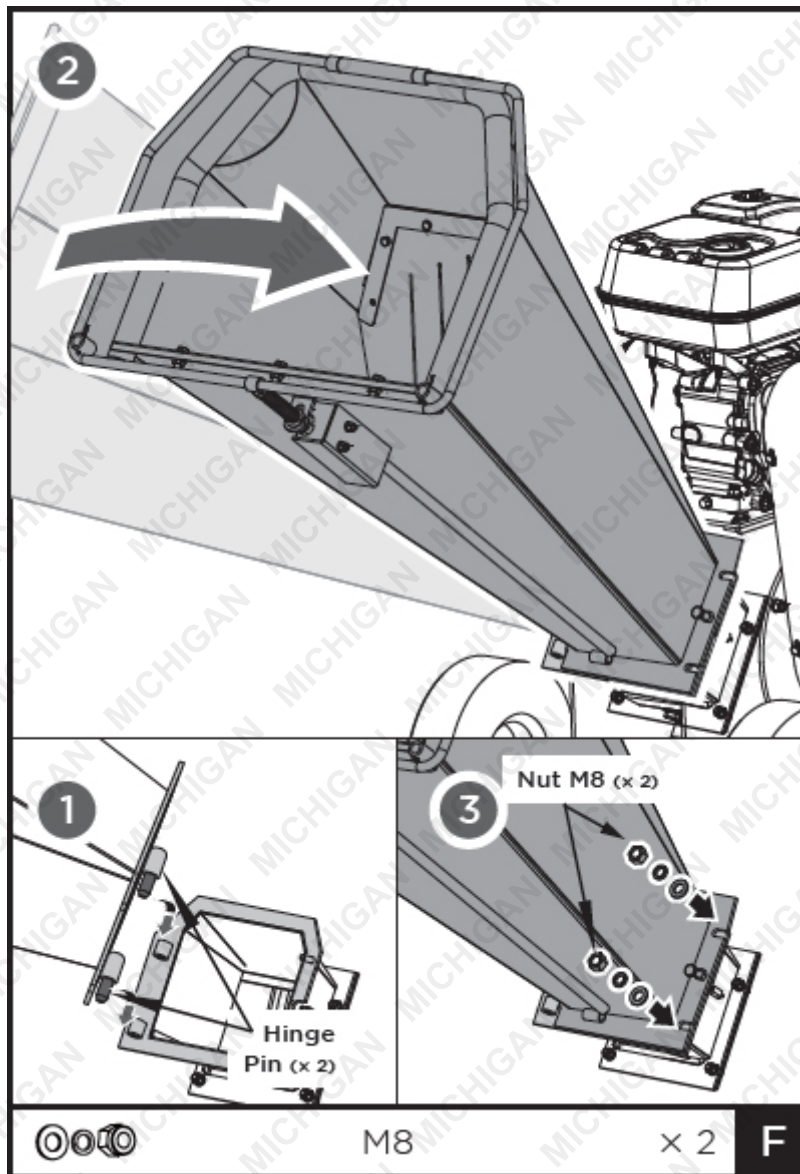

Tip: It is recommended to have another person assist you in lifting and supporting the hopper until it is securely fastened to the chipper.

Discharge Chute

1. Slide the hinge pins of the discharge chute fully into the bushings on the drive housing weldment.
2. Close the chute onto the machine and secure it using washers and knobs.

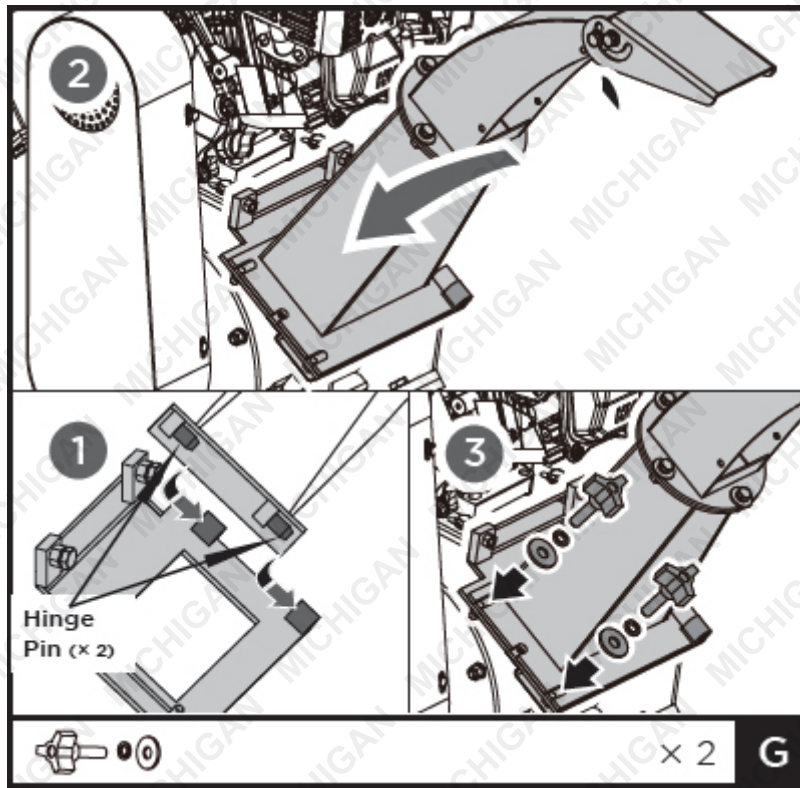

Emergency Stop Handle

1. Insert both ends of the U-shaped emergency stop handle into the sockets on the hopper.
2. Secure each end with a cotter pin.

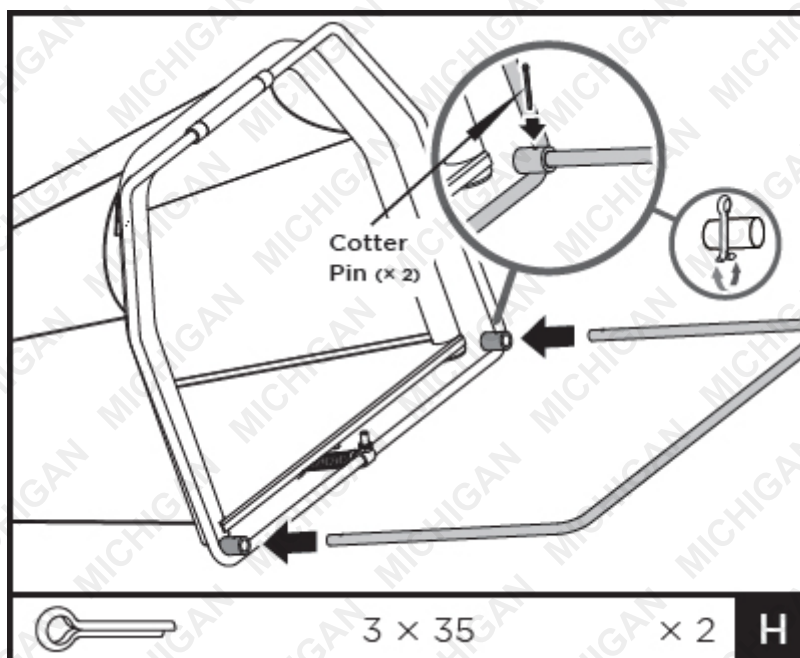

Feed Tray

Attach the feed tray to the feed hopper using the appropriate bolts, washers, and nuts.

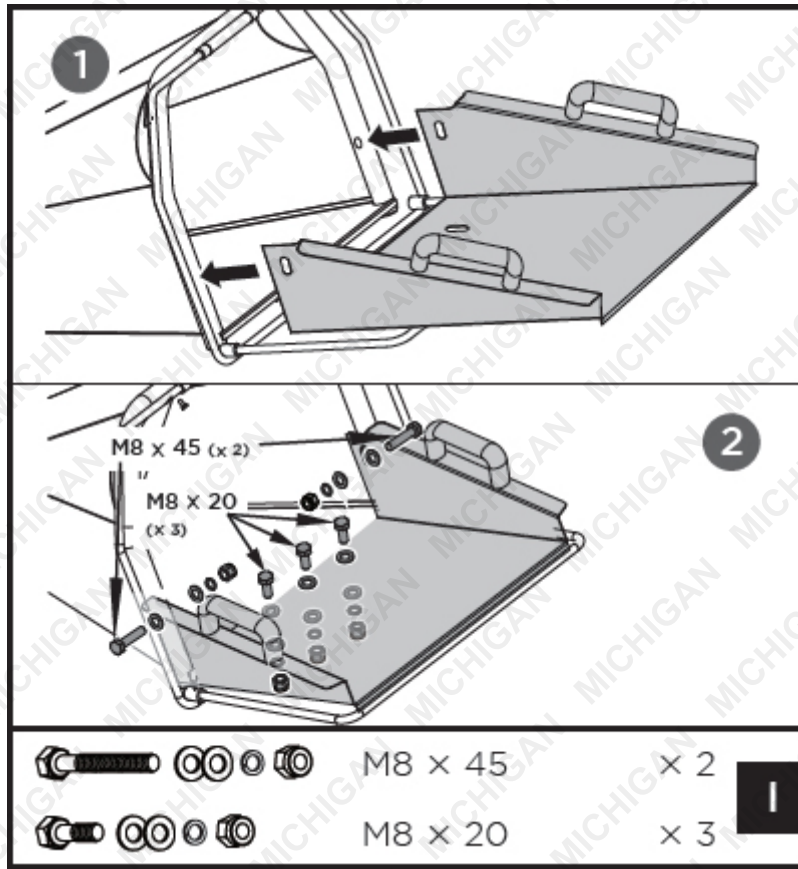

Emergency Stop Switch

1. Position the emergency stop switch on the feed hopper, aligning the mounting holes.
2. Secure it using four M6 x 12 mm bolts and washers.

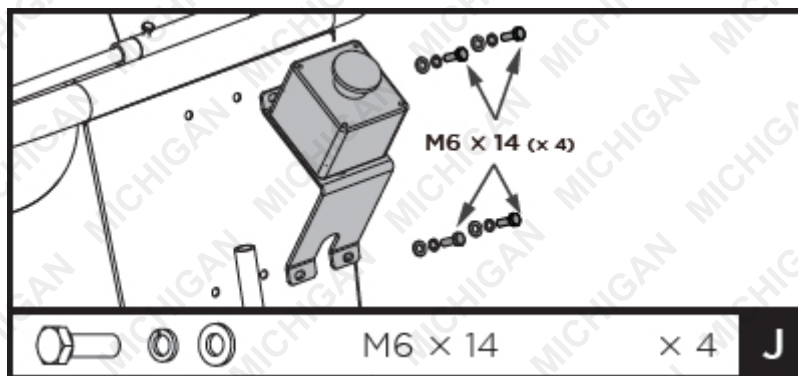

Guard Net for Discharge Outlet

1. Attach the guard net to the front opening of the upper discharge chute.
2. Align the holes and secure it with four M6 × 14 mm bolts and washers.

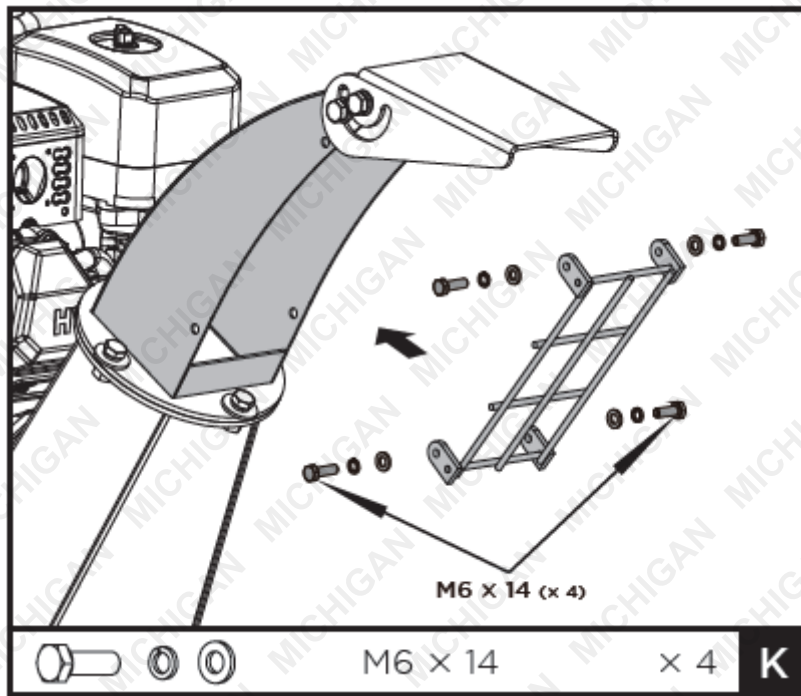

Emergency Stop Wire Connection

⚠ WARNING! EMERGENCY STOP

ENSURE THE EMERGENCY STOP WIRE IS PROPERLY CONNECTED. FAILURE TO DO SO MAY CAUSE DEATH OR SERIOUS INJURY.

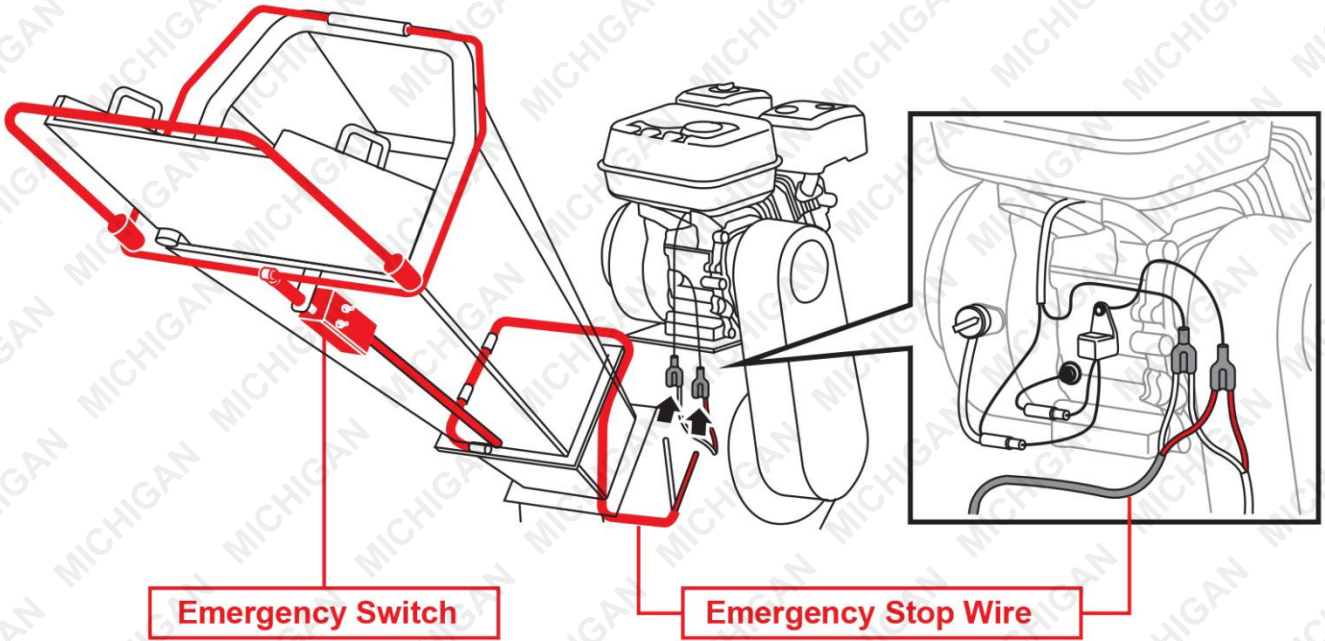

EMERGENCY STOP



Emergency Stop Handle

Know Your Wood Chipper

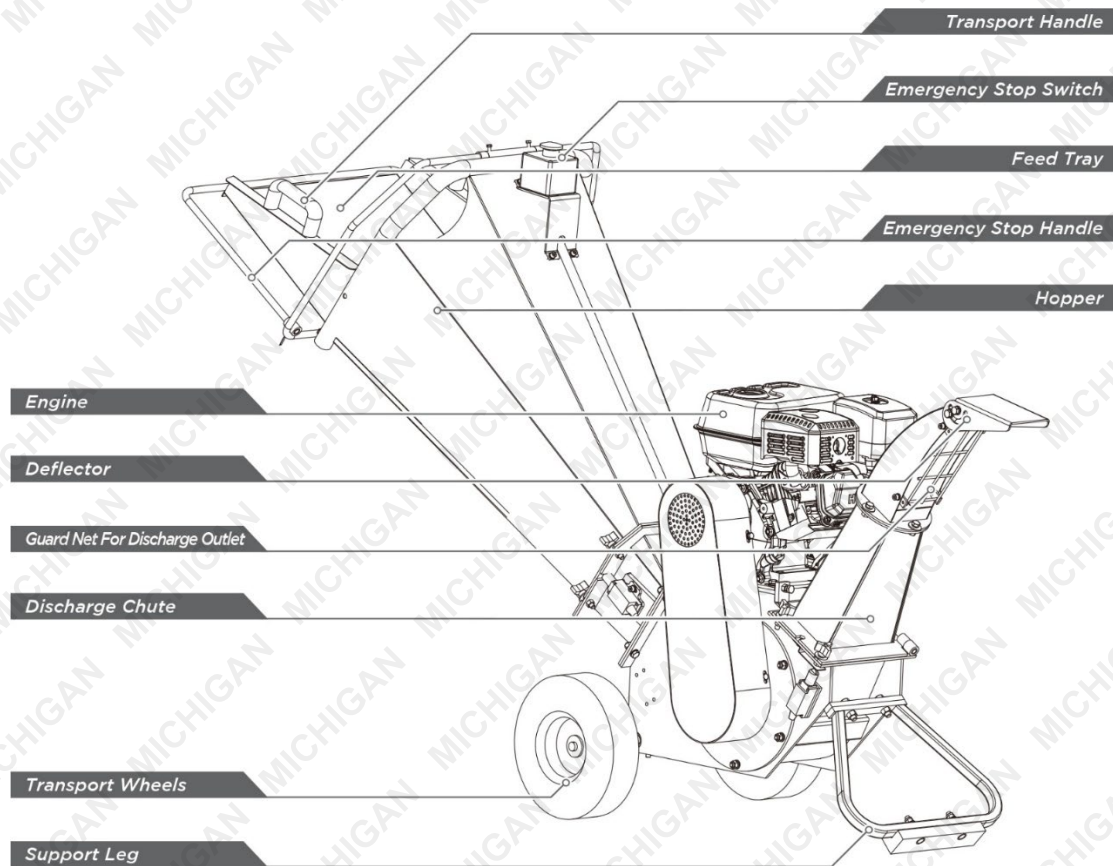

Feed Hopper

This is the entry point for materials to be chipped. Insert branches and debris into the feed hopper for processing.

Discharge Chute

Chipped materials exit through the discharge chute. A deflector can be attached to help control the direction of discharge.

Transport Handle

Use the transport handles to move or reposition the machine as needed.

Transport Wheels

To move the chipper:

1. Grip the handles at the top of the hopper.
2. Tilt the machine backwards until it rests securely on the wheels, then roll it to the desired location.

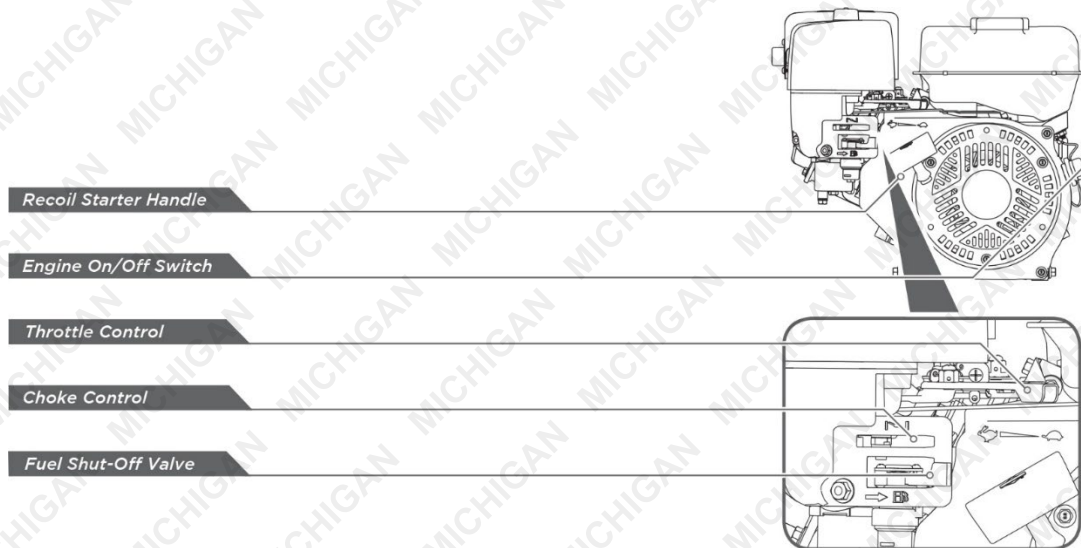

Engine On/Off Switch

This switch controls the engine's operation:



- OFF – The engine will not start or run.
- ON – The engine is ready to start and operate.

Recoil Starter Handle

Pull the recoil starter handle to start the engine manually.



Fuel Shut-Off Valve

The fuel shut-off valve has two positions:

- **CLOSED** () – Use this position when servicing, transporting, or storing the unit.
- **OPEN** () – Use this position to operate the unit.



Choke Control

Assists with starting the engine by regulating airflow to the carburettor. The control slides between:

- **CHOKE CLOSED** () – For cold starting.
- **CHOKE OPEN** () – For normal operation after the engine warms up.

Throttle Control

Regulates engine speed and shuts off the engine when moved to the STOP position. It has three settings:

- **FAST** () – For normal operation.
- **SLOW** () – For idle or low-speed operation.
- **STOP** – Shuts off the engine.

Wood Chipper Operation

Important: The engine is shipped without oil. Do not start the engine until oil has been added.

Adding Oil to the Engine

1. Place the chipper on a flat, level surface.
2. Remove the oil fill cap/dipstick.
3. Using a funnel, add engine oil until it reaches the FULL mark on the dipstick.

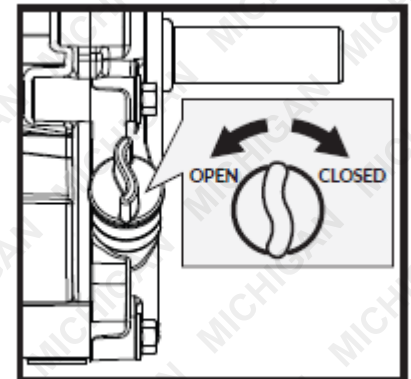

Do not overfill. Check the engine oil level daily and top up as needed.

Adding Petrol to the Engine

⚠ DANGER: Petrol is highly flammable and explosive. Mishandling fuel can result in burns or serious injury. Use extreme caution when handling petrol.

Only refuel outdoors. Never fill the fuel tank indoors or in an enclosed space—petrol vapours can ignite and cause an explosion.

1. Ensure the engine is switched off and has been allowed to cool for at least 2 minutes before refuelling.
2. Remove the fuel filler cap and fill the tank with unleaded petrol.

Important: Do not overfill the tank.

This machine may contain evaporative emissions control components designed to function only when the fuel tank is filled to the recommended level. Overfilling can:

Damage the emissions control system permanently.

Prevent fuel expansion by eliminating the required vapour gap.

Use a portable petrol container with a proper dispensing spout to fill the tank. Do not use a funnel or any device that obstructs your view of the fuel level.

3. Reinstall and tighten the fuel cap securely.
4. Wipe away any spilled fuel immediately.

Starting the Engine

⚠ WARNING: Do not allow the starter cord to retract rapidly (kickback). Sudden pullback may cause serious injuries such as sprains, bruises, fractures, or broken bones.

1. Turn the engine switch to the ON position.



2. Open the fuel shut-off valve.

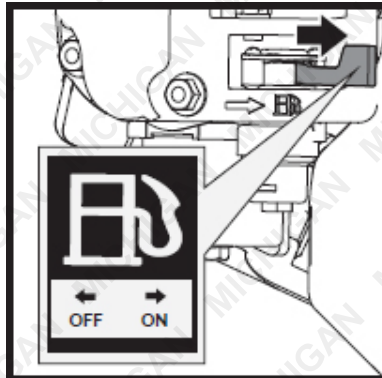

3. Set the choke lever to the CLOSED position.

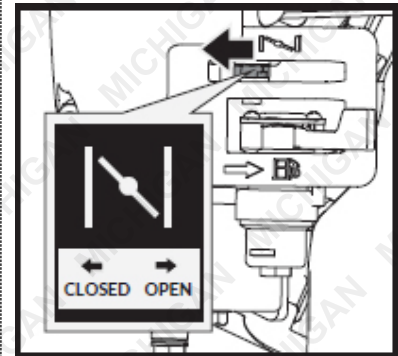

Note: If the engine is already warm, choking may not be necessary.

4. Move the throttle lever slightly toward the FAST setting.

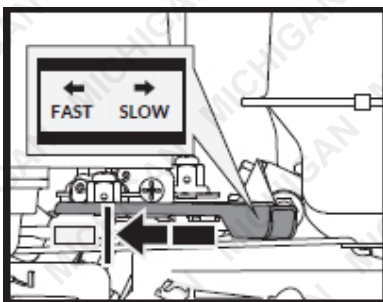

5. Start the engine:
 - a. Pull the recoil starter slowly until resistance increases (compression stroke).
 - b. Allow the starter cord to return to its home position.
 - c. Pull sharply and firmly to start the engine. Repeat if necessary.

6. Once the engine starts:
 - a. Gradually open the choke fully.
 - b. Set the throttle to the FAST position before beginning operation.

Operating the Chipper Shredder

Before You Begin

- After the engine has warmed up, move the throttle lever to the FAST position to increase engine speed.
- Ensure the machine is on a level and stable surface to reduce vibration.
- Do not operate the machine on concrete or other hard surfaces to avoid damage or instability.

Note: The engine is equipped with an oil alert system. It will not start if the oil level is too low, and may shut off if operated on a steep incline.

Suitable Materials

The chipper shredder can handle a variety of dry or green organic materials, including:

- Branches (refer to the product listing for max branch diameter)
- Stalks, vines, and leaves
- Roots and vegetable matter
- Maximum chipping capacity may vary depending on wood type and hardness.

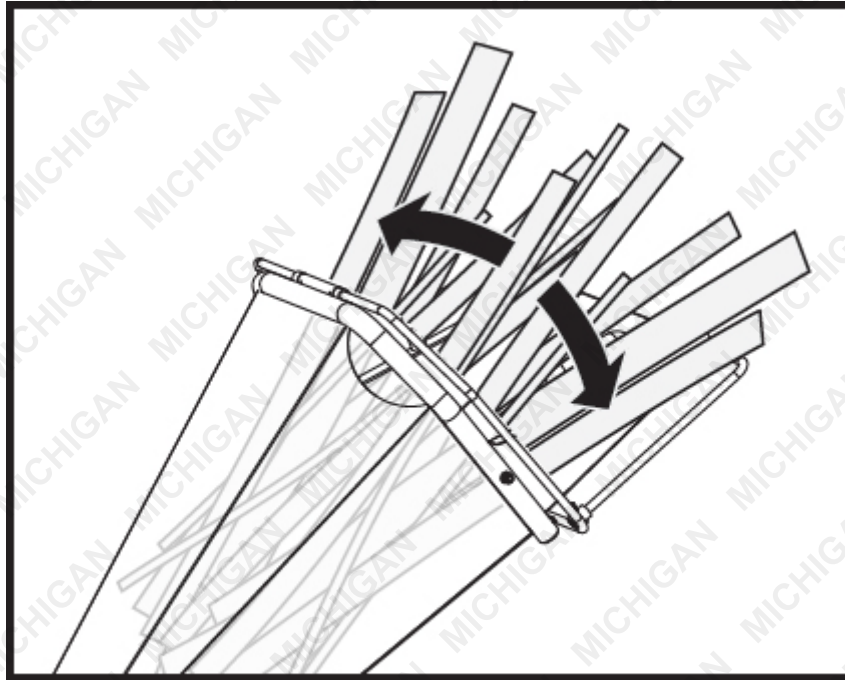

Feeding Tips

- Insert branches cut-end first, leaving the bushy ends on. This helps guide the limb through the hopper and reduces kickback or bouncing.
- Rotate branches while feeding to improve chipping performance.
- Pre-cut side branches if needed to promote self-feeding.
- Always chip freshly cut material where possible. Dry wood can become springy, dulling blades faster.
- Keep a wooden stick (approx. 25 mm × 600 mm) handy to help feed short, leafy, or brushy material and keep the hopper clear.
- Do not force material into the machine. If it struggles to chip, the knives may need replacing.

Preventing Overload

- Do not overload the feed hopper. If the engine speed drops:
 - Stop feeding material immediately.
 - Wait for the engine to return to full speed before resuming.

Raptor 1100 Wood Chipper

- Avoid feeding large amounts of soft, wet, or fibrous material continuously. Feed these intermittently with branches to prevent clogging.

If stringy material wraps around the rotor shaft, stop the machine and remove it to prevent bearing damage.

In Case of Clogging or Stalling

If the machine stalls due to overload or clogging:

1. Turn the engine switch OFF.
2. Wait for the cutting disk to stop completely and the belt drive to disengage.
3. Allow the engine to cool down fully.
4. Open the discharge chute or feed hopper and remove all material.
5. Once cleared, close and lock all access points.
6. Switch the engine back ON and restart the unit.

As material discharges, move the chipper away from the pile to prevent backup into the chute.

Deflector Use

- Do not position the deflector vertically - this reduces airflow and may cause blockages.
- Always maintain a clear discharge path to ensure efficient operation.

Shutting Down the Machine

To stop the chipper:

1. Move the throttle control lever to IDLE.
2. Turn the engine switch to the OFF position.
3. Wait for the machine to come to a complete stop.

Emergency Stop

- Check the emergency stop switch before each use. Failure to ensure its proper function may result in serious injury or death.
- The emergency stop wire must be routed around the left side of the hopper (as viewed from the operator's position).

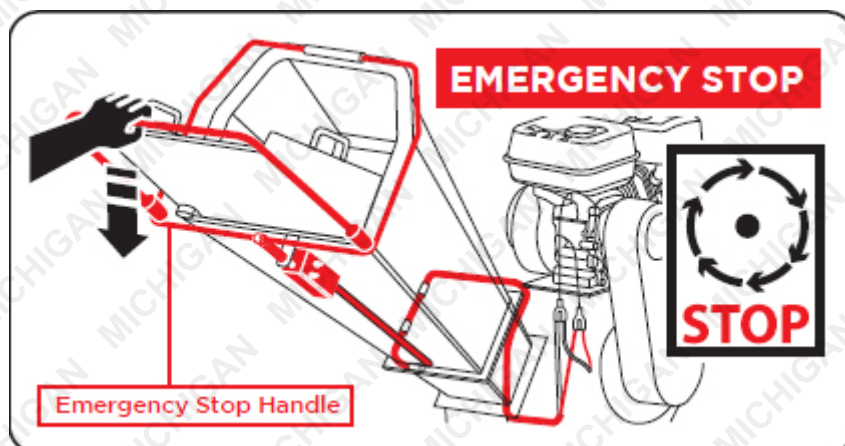



Idle Speed

- Set the throttle control lever to the SLOW position when the chipper is running but not actively chipping.
- Running the engine at idle:
 - Reduces engine wear
 - Conserves fuel
 - Minimises noise

Stopping the Engine

To stop the engine in an emergency: Simply turn the engine switch to OFF.

Normal Shutdown Procedure

1. Move the throttle lever to the SLOW () position.
2. Let the engine idle for 1–2 minutes to cool gradually.
3. Turn the engine switch to OFF.
4. Turn the fuel shut-off valve to OFF ()

⚠ Do not stop the engine suddenly under heavy load and high speed. This may cause internal engine damage. Do not use the choke control to stop the engine. Doing so may cause backfire or engine damage.

After Stopping

- Wait for all moving parts to come to a complete stop.
- Allow the engine to cool completely.
- If performing maintenance or storage:
 - Remove the spark plug.
 - Clean out the machine's interior and discharge chute thoroughly.

Storage Positioning: Place the machine on solid, level ground during use and storage. Secure the unit to the ground with bolts to prevent tipping or movement.

Transporting

This chipper is equipped with large wheels for easy manual movement.

To transport the unit:

1. Ensure the oil tank cap is securely tightened.
2. Grip the transport handles firmly.
3. Tilt the chipper slightly backward until it rests on its wheels.
4. Move the unit carefully to the desired location.

⚠ Note: This machine is designed for manual transport only. Do not tow it with a vehicle or move it on public roads.

Wood Chipper Maintenance

ATTENTION: Surface corrosion will occur on metal surfaces over time and the rate of oxidation depends on factors such as proximity to the ocean and humidity or condensation of water vapour on metal surfaces. To mitigate this, WD40 can be used to remove surface corrosion then, when applied periodically, it will prevent rust from forming.

Regular maintenance will help ensure the long life and reliable performance of your wood chipper.

Preventive Maintenance

1. Shut down the engine and allow it to cool completely.
2. Move the throttle lever to the SLOW position.
3. Remove the spark plug wire and secure it away from the spark plug.
4. Inspect the general condition of the chipper:
 - Look for loose bolts or screws,
 - Check for misalignment or binding in moving parts,
 - Examine for cracks, wear, or damage that could affect safe operation.
5. Clean the machine thoroughly using a soft brush, vacuum, or compressed air.
6. Lubricate all moving parts with a high-quality, lightweight machine oil.

Bearing Maintenance

- The chipper has two bearings—one outside and one inside the housing.
- These are greased during assembly, but:
 - Apply grease after the first few hours of use.
 - One or two pumps of grease is sufficient.
 - Do not over-grease—excess lubrication can damage the bearings.

Final Steps

Once all maintenance is complete, reconnect the spark plug wire securely.

⚠ Important Cleaning Note: Never use a pressure washer to clean the chipper. Water may enter tight areas and damage spindles, pulleys, bearings, or the engine.

⚠ Always wait until the engine and all moving parts have come to a complete stop. Remove the spark plug wire and wait at least 5 minutes before performing any maintenance tasks.



Regular Maintenance Checklist

The table below outlines the recommended maintenance intervals under normal operating conditions.

⚠ Note: If operating in extremely dirty or dusty environments, perform maintenance more frequently than listed.

Procedure	Before Each Use	After First 15 Minutes	Every 25 Hours	Every 100 Hours
Check engine oil level	✓	✓		
Check general equipment condition	✓	✓		
Check blades	✓	✓		
Check belts	✓	✓		
Check emergency stop switch			✓	
Check tyre pressure			✓	
Clean engine exterior and cooling fins			✓	
Change engine oil			✓	
Replace air filter			✓	
Replace spark plug				✓

Greasing the Outside Bearing

1. Remove the plastic oil plug to access the grease port.
2. Apply grease to the outside bearing through the filling hole.

Use only a small amount—one or two pumps is sufficient.

3. Reinstall and tighten the plastic oil plug after greasing.

⚠ Do not over-grease. Excess grease can damage the bearing and affect performance.

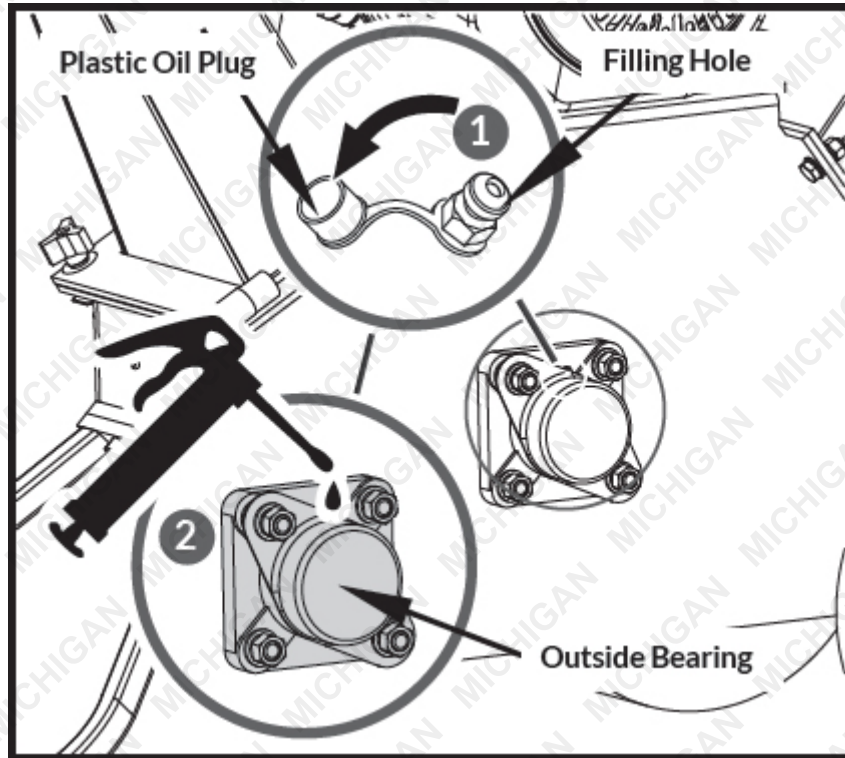

Greasing the Inside Bearing

1. Unscrew the four M6 × 2 bolts to remove the belt cover.

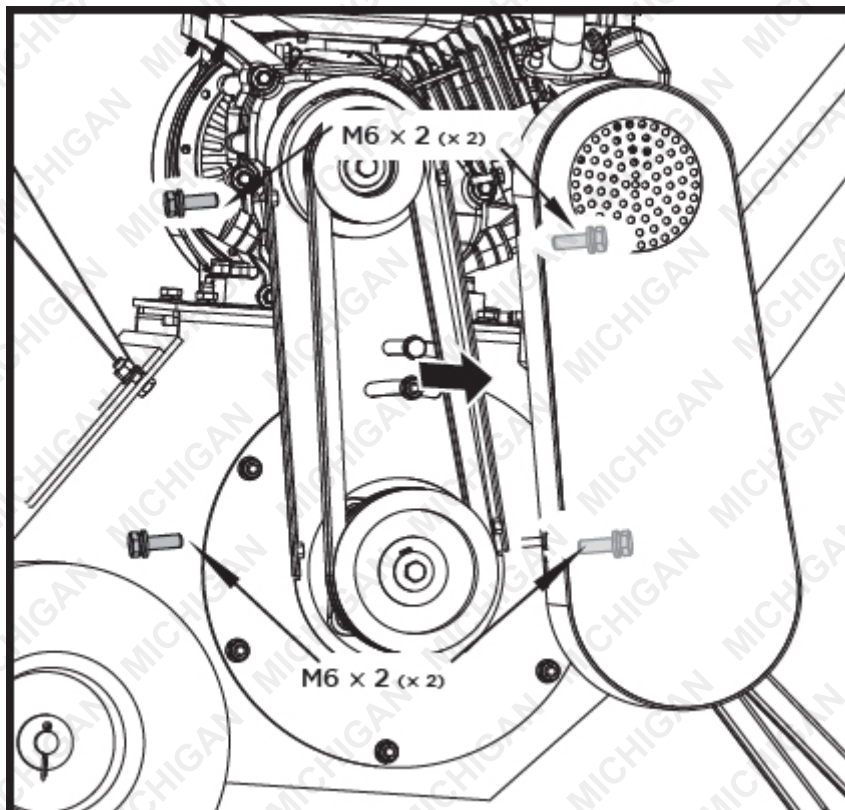

2. Apply grease to the inside bearing through the appropriate grease point.

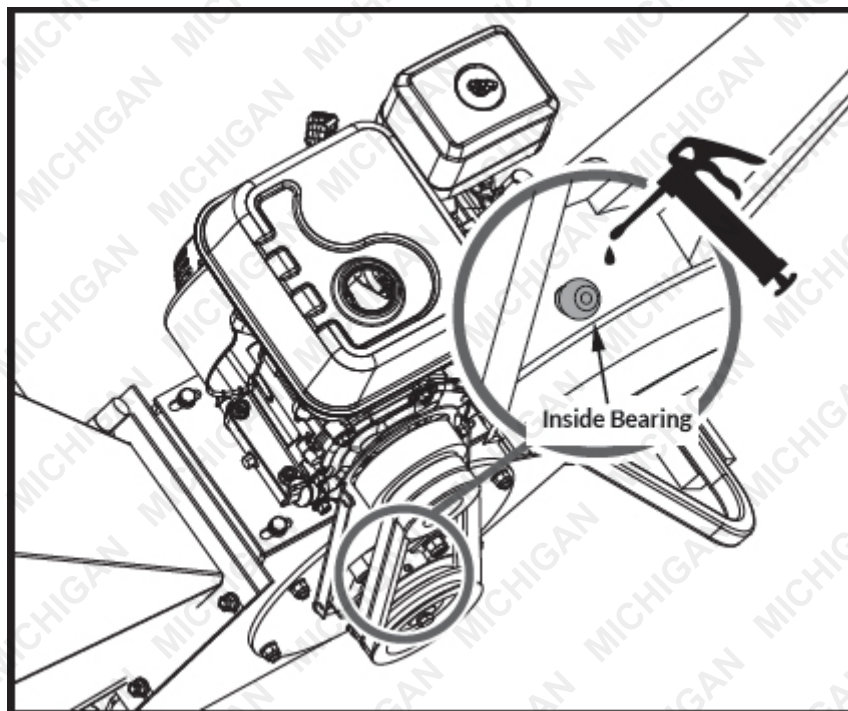

Be careful not to over-grease—one or two pumps is sufficient.

If the Machine Strikes a Foreign Object or Vibrates Excessively

If the cutting disk hits a foreign object or the machine begins to make unusual noises or vibrations:

1. Immediately switch the engine OFF and allow the cutting disk to come to a complete stop.
2. Perform the following checks:
 - Inspect for damage.
 - Repair or replace any damaged parts.
 - Check for loose parts and tighten them securely to ensure safe operation.
3. If the cutting disk becomes jammed with branches:
 - a. Open the bearing cover.
 - b. Use a wrench to manually rotate the disc shaft to free the obstruction.

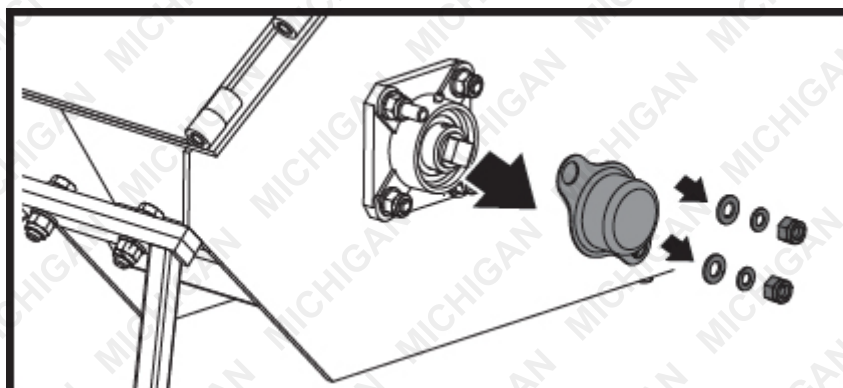

⚠ Always ensure the engine is switched OFF and cannot start accidentally during inspection or repair.

Knife and Wear Plate Inspection

Regular inspection of the chipping knives and wear plate is essential for maintaining peak performance.

- Ensure the knives remain sharp and the wear plate edge is crisp.
- Dull knives or a rounded wear plate will reduce chipping efficiency, increase vibration, and place undue strain on the machine.
- Excessive vibration caused by worn components can lead to mechanical damage and make operation more difficult and unsafe.

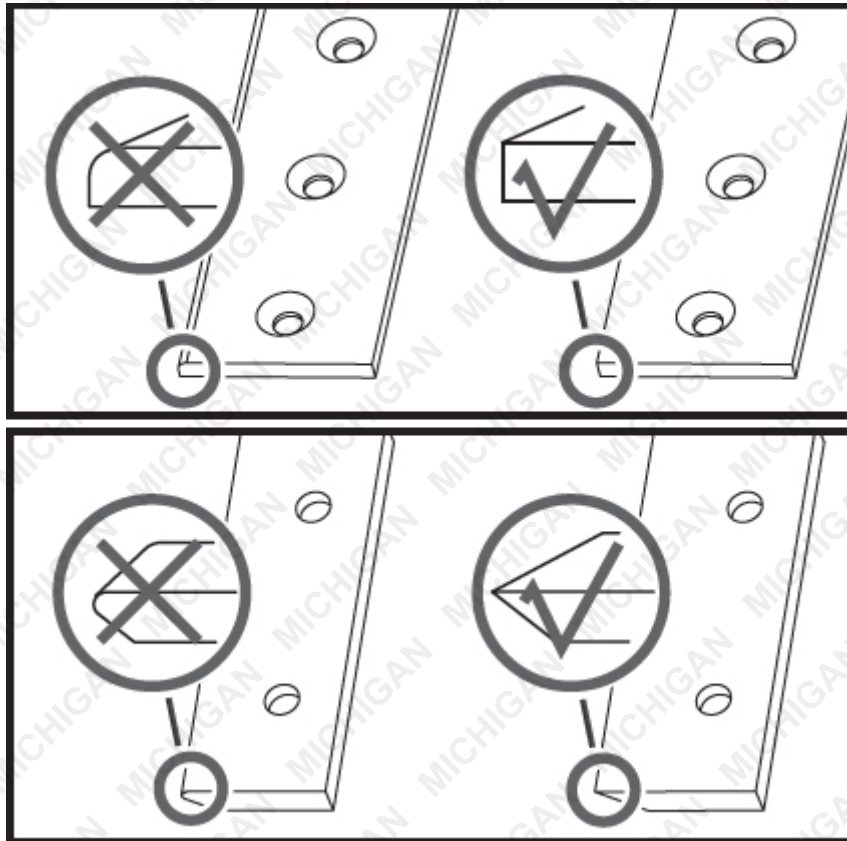

*** Tip: Check the knives and wear plate periodically as part of your routine maintenance schedule and replace or sharpen as needed.**

Knife Removal and Replacement

This chipper shredder is equipped with two reversible chipper knives mounted on the cutting disc.

Over time, knives may become dull or develop visible nicks, reducing the chipper's ability to self-feed. Dull knives can result in:

- Material needing to be pushed manually
- Long, unchipped strips being discharged
- Excessive vibration

Each knife is case-hardened and reversible:

- When one edge becomes rounded or dull, you can reverse the knife.

Raptor 1100 Wood Chipper

- When both edges are worn, the knife must be replaced.

Knife Replacement Procedure

1. Remove the two M8 nuts and open the feed hopper.

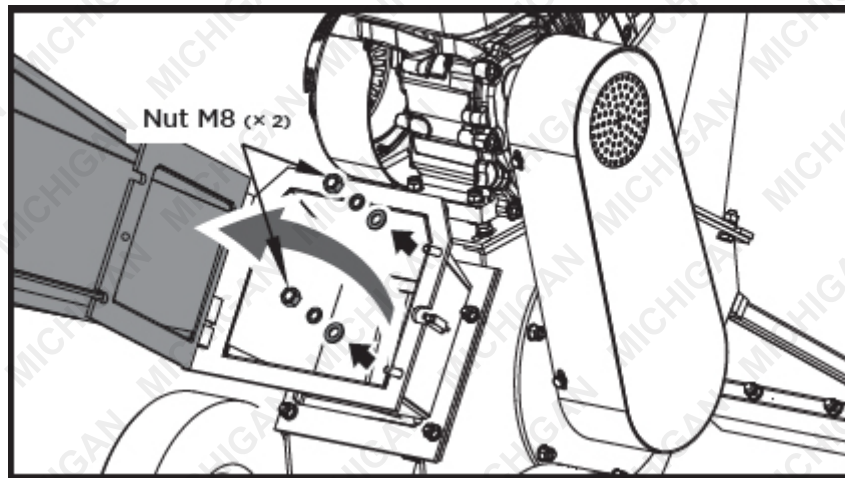

2. Rotate the cutting disc by hand until a knife is visible through the hopper opening.
3. Carefully remove the bolts securing the knife.

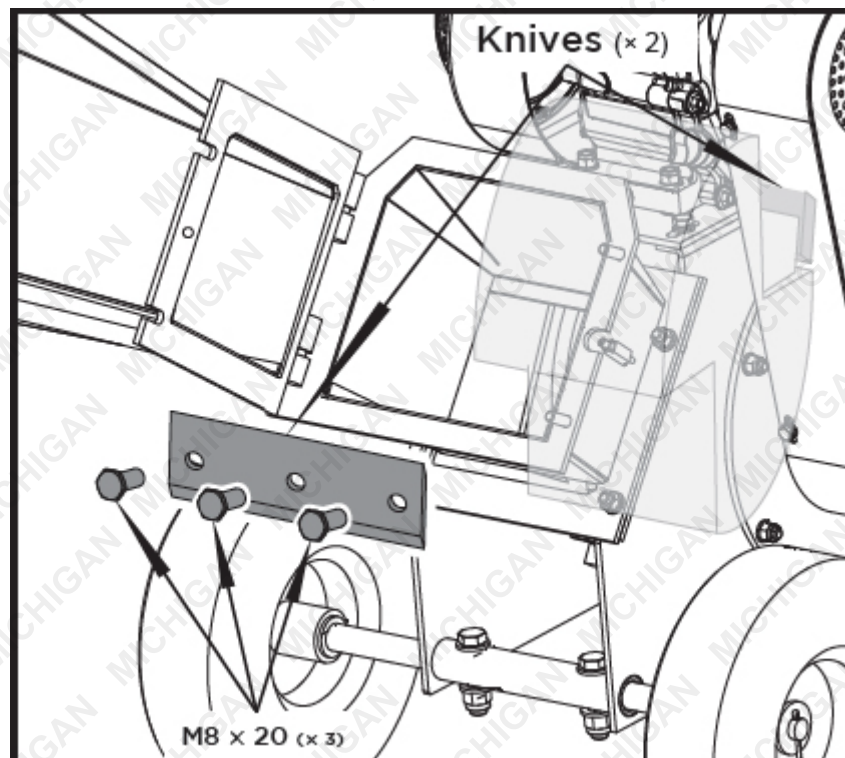

⚠ Wear protective gloves when working near sharp edges.

4. Remove the dull or damaged knife and inspect the cutting disc slot:
 - Ensure the mounting surface is clean and free from debris.
 - The replacement knife must sit flush against the disc.

Raptor 1100 Wood Chipper

5. Install the new or sharpened knife, making sure the cutting edge faces up.
6. Re-secure the bolts tightly.

⚠ If the disc surface is not cleaned properly or if the knife is not mounted flush, tightening the bolts may cause the knife to crack or fail during operation.

Wear Plate Removal and Replacement

The wear plate is case-hardened and reversible. While the edges are durable, they will eventually wear down with use.

- When one edge becomes rounded, the plate can be reversed.
- The wear plate cannot be resharpened—doing so removes the hardened surface.
- Once both edges are worn, the plate must be replaced.

Replacement Procedure

1. Remove the feed hopper to access the wear plate.
2. Remove the bolts and locknuts securing the wear plate to the chipper assembly, then remove the plate.

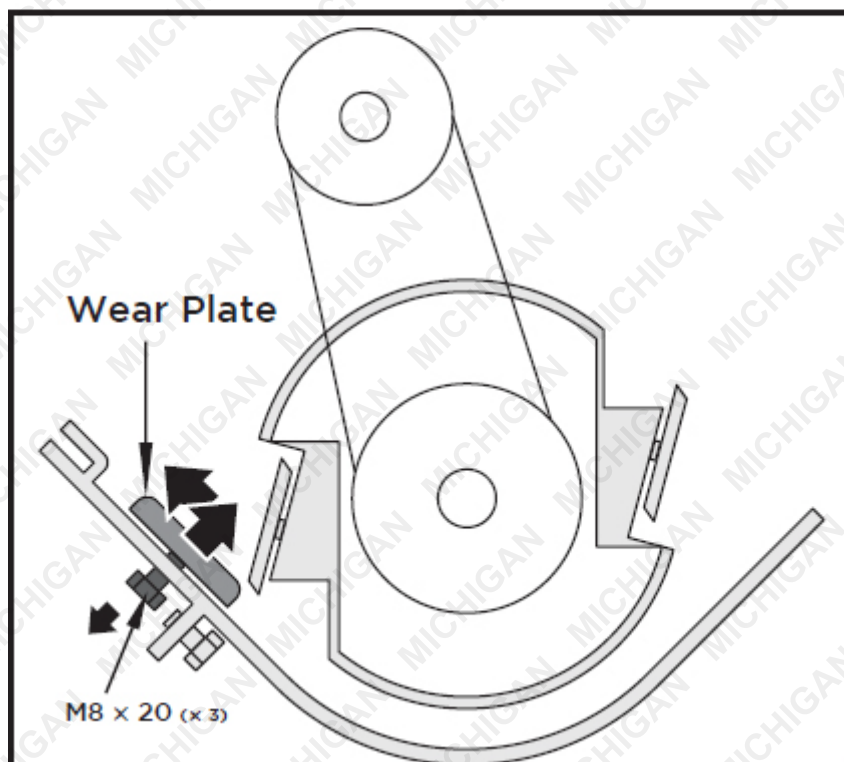
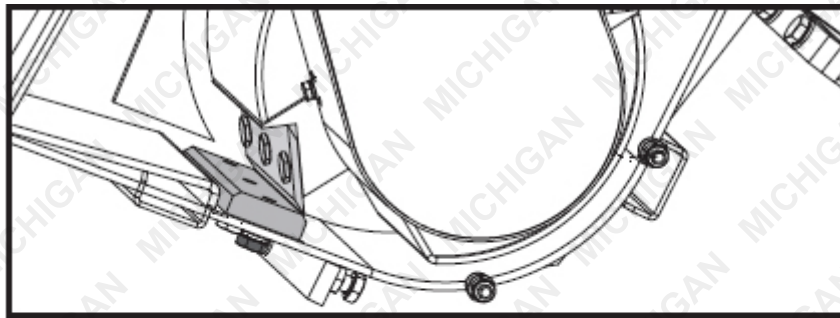

3. Install the new or reversed wear plate and secure it with the bolts and locknuts.

Adjusting the Knife-to-Wear Plate Clearance

After reinstallation, you must adjust the gap between the knife and wear plate:

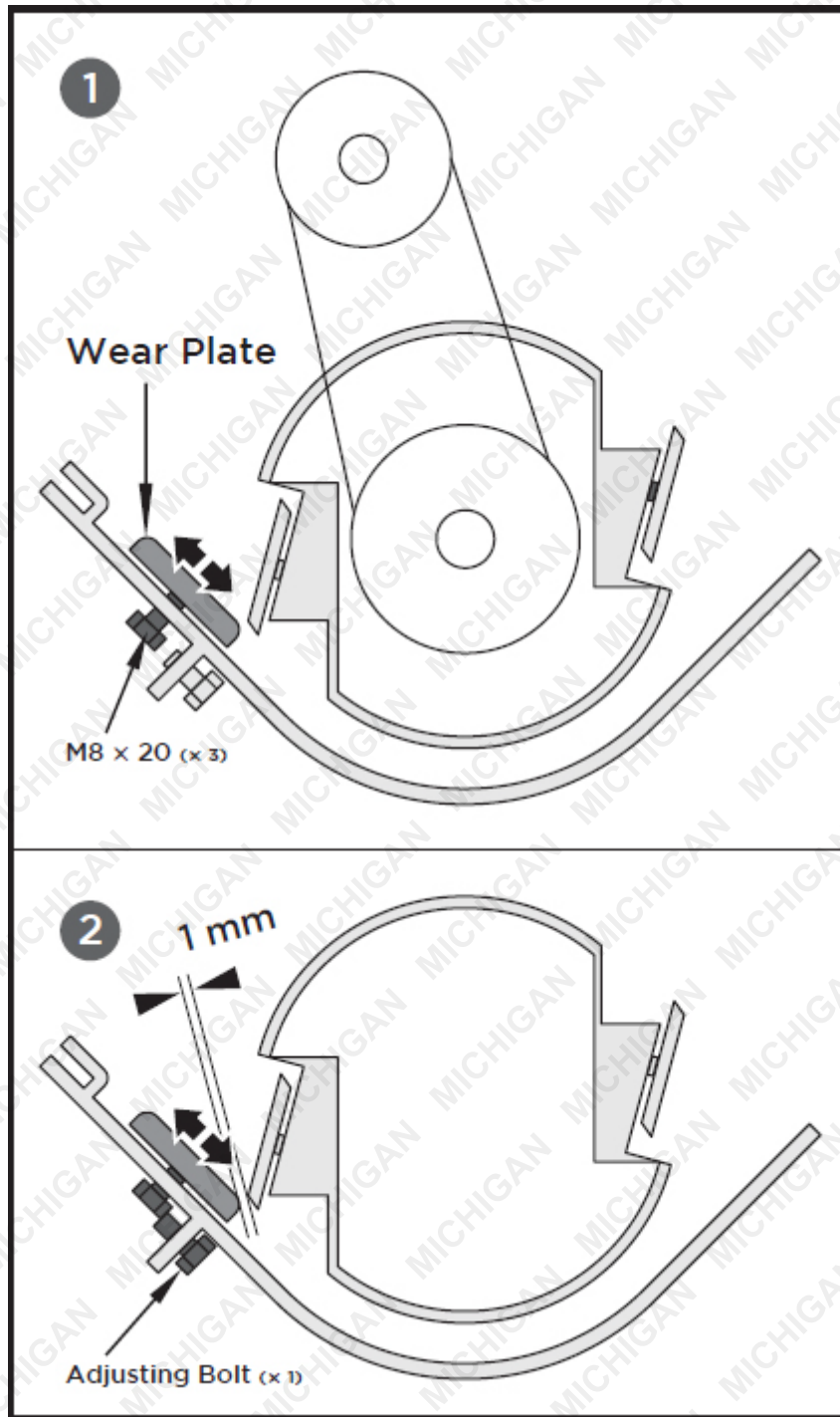

- The wear plate is mounted with slotted holes for adjustment.
- Loosen the mounting bolts, reposition the wear plate within the slots to achieve the correct clearance, then retighten the bolts securely.

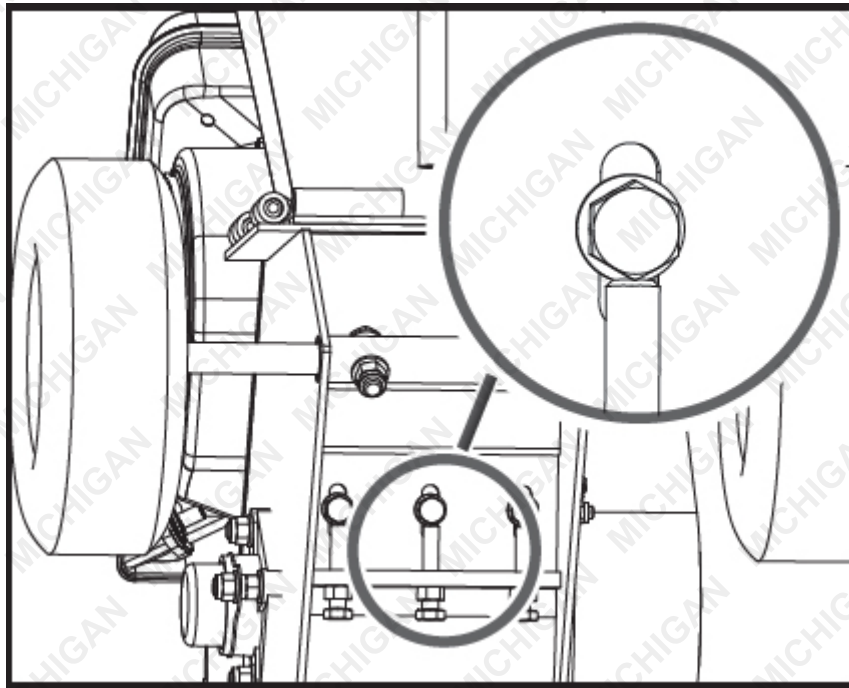

⚠ Correct gap adjustment is critical:

Too little clearance may cause the knife to strike the wear plate during cutting, especially under deflection from heavy branches—damaging the cutting edge.

Too much clearance may allow small twigs or fibrous material to pass through uncut, reducing performance.

Incorrect adjustment may also result in excessive vibration, making the machine feel as though the knife is dull.

Final Safety Check

After adjustments:

- Manually rotate the cutting disc using a stick.
- Watch and listen carefully for any:
 - Unusual noises
 - Clicking
 - Vibration

If anything abnormal is detected, inspect for damage or loose parts and repair, replace, or tighten as necessary before restarting the machine.

V-Belt Inspection and Adjustment

Routine inspection of the V-belts is essential to maintain proper power transmission and safe operation.

Procedure

1. Unscrew the four M6 × 2 bolts and remove the belt cover.

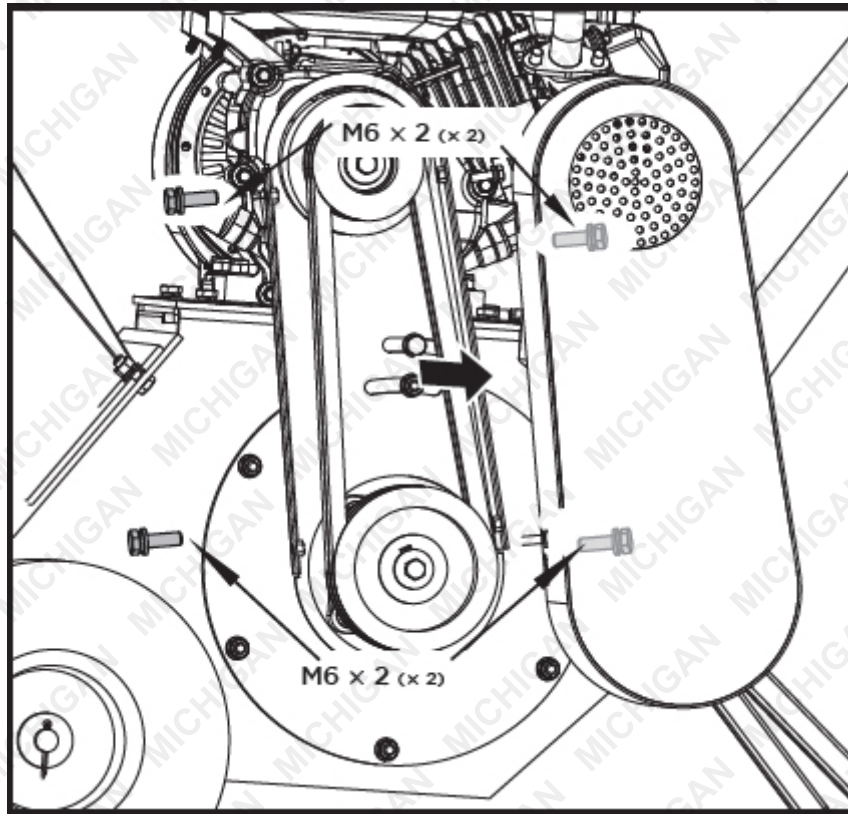

⚠ Important: When adjusting or inspecting the belt(s), ensure the engine pulley is aligned with the cutting disc pulley to avoid premature wear or slippage.

2. Inspect the condition of the V-belts:
If any belt appears cracked, frayed, or glazed, it must be replaced immediately.
3. Check the belt tension:
 - Press on the centre of the belt span using moderate thumb pressure.
 - Each side should deflect approximately 10 mm (3/8 inch).
 - If tension is too loose or too tight, adjust accordingly to prevent slippage or excess wear.

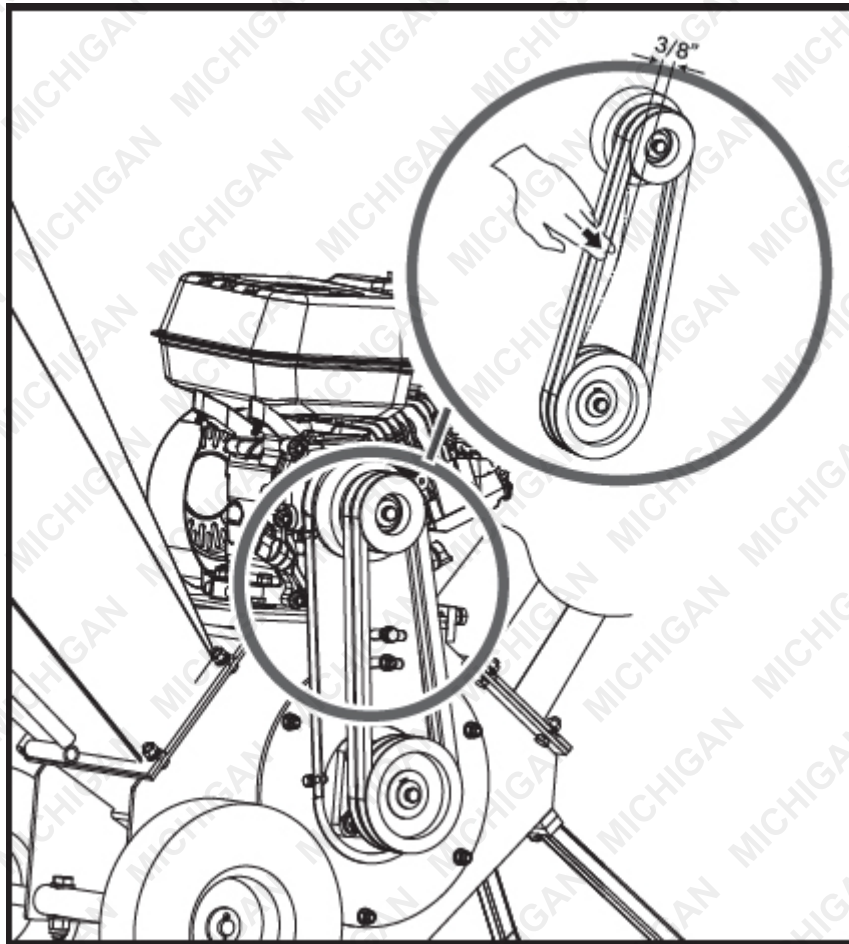

V-Belt Tensioning

Correct V-belt tension is essential for optimal chipper performance and long belt life.

⚠ Too much or too little tension can cause premature belt wear or failure.

Tension Adjustment Procedure

1. Turn off the engine and allow it to cool completely.
2. Remove the belt cover.
3. Loosen the four engine mounting bolts.
4. Loosen the two limit bolts at the front of the engine base.
5. Adjust belt tension by moving the engine:
 - Away from the cutting disc to tighten the belt.
 - Toward the disc to loosen the belt.

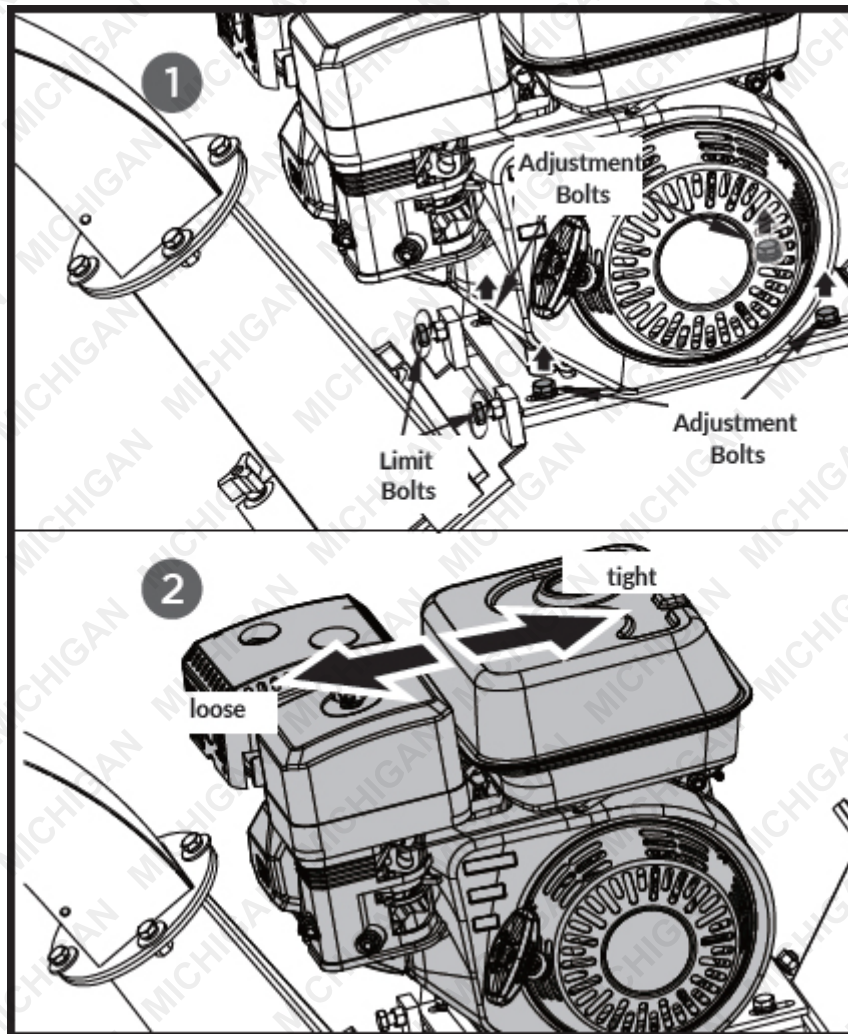

6. Once proper tension is achieved:

- Tighten the four engine bolts.
- Retighten the two limit bolts to secure the engine position.

Fine-Tuning (If Too Tight)

- If the V-belt is too tight, loosen it by moving the two M12 adjustment nuts upward.
- Adjust the sleeve between the nuts to fine-tune belt slack.

Tension Check

- Squeeze the centre of the belt span with moderate thumb pressure.
- The belt should deflect approximately 10 mm (3/8 inch) on each side.

V-Belt Replacement

⚠ Important: Always replace both V-belts at the same time. They wear evenly under normal use, and replacing only one may lead to uneven performance or premature failure.

Replacement Procedure

1. Unscrew the four M6 × 2 bolts and remove the belt cover.
2. Loosen the engine mounting bolts, then shift the engine towards the belt slackening direction to relieve belt tension.
3. Carefully remove the worn or damaged belts and install both new V-belts onto the pulleys.

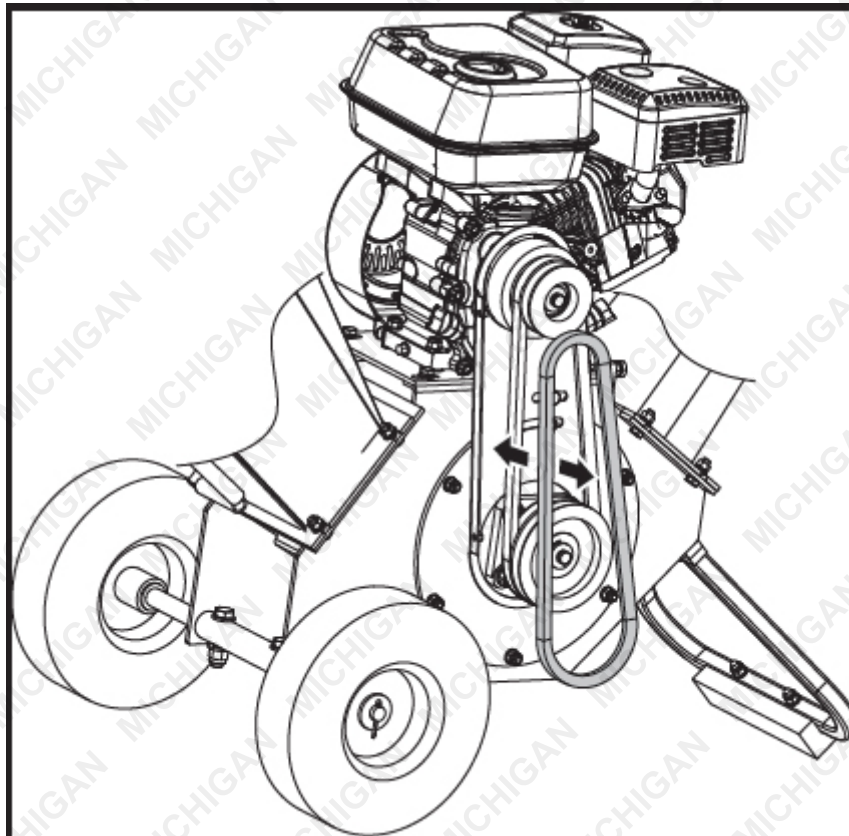

⚠ WARNING: Keep hands and fingers clear of pinch points between the belts and pulleys during removal or installation.

4. Check belt tension:
 - Apply moderate pressure to the centre of the belt span.
 - Each side should deflect approximately 10 mm (3/8 inch).
5. Once correct tension is set, secure the engine in place by tightening all mounting bolts.



Lubrication

- Grease the bearings every 40 hours of operation.
- Be careful not to over-grease, as excess grease can damage the bearings.
- This unit has two bearings: one outside and one inside the housing.

Recommended Grease

Use a portable tool lithium #0 grease such as:

- Lubricant 6300AA
- Lubricant GR-132
- Multifak EP-0

Engine Maintenance

The Importance of Maintenance

Proper maintenance is critical to ensure safe, efficient, and reliable operation of your engine. Routine care not only extends engine life but also helps to reduce air pollution.

⚠ WARNING: Improper maintenance or operating the engine with known issues can result in mechanical failure, serious injury, or death. Always follow the maintenance schedule and inspection procedures outlined in this manual.

This section provides a basic maintenance schedule, inspection guidelines, and procedures that can be completed using standard tools.

Tasks requiring specialised tools or technical expertise should be handled by a qualified technician or service centre.

If your engine is used in severe conditions (e.g. dusty environments, high temperatures, or extended high-load operation), consult your servicing dealer for adjusted maintenance intervals.

Engine Maintenance Safety

⚠ WARNING: Failure to follow safety precautions during maintenance can result in serious injury or death.

General Safety Guidelines

- Turn off the engine before performing any maintenance. This prevents:
 - Carbon monoxide poisoning – Ensure proper ventilation when running the engine.
 - Burns – Let the engine and exhaust cool completely.
 - Injury from moving parts – Never perform maintenance while the engine is running unless instructed.
- Read all instructions carefully before starting.
- Ensure you have the necessary tools and skills to complete the task.
- Do not use petrol to clean parts. Use only non-flammable solvents.
- Keep cigarettes, sparks, and flames away from fuel-related components.
- For best results, use genuine replacement parts or approved equivalents.

Your servicing dealer is the best resource for reliable repairs and maintenance. They are equipped with the correct tools, parts, and expertise to maintain your engine safely and effectively.



Raptor 1100 Wood Chipper

Engine Maintenance Schedule

Perform maintenance at the indicated time interval or engine hour, whichever comes first. This schedule is based on normal operating conditions.

⚠ If used in dusty, wet, or extreme environments, increase the frequency of maintenance accordingly.

Item	Each Use	First Month / 20 Hrs	Every 3 Months / 50 Hrs	Every 6 Months / 100 Hrs	Every Year / 300 Hrs
Engine oil	Check level	●			
	Change		●	●	
Air cleaner	Check	●			
	Clean		● (1)		
	Replace				●★
Sediment cup	Clean			●	
Spark plug	Check / Clean			●	
	Replace				●
Spark arrester (if equipped)	Clean			●	
Idle speed	Check / Adjust				● (2)
Valve clearance	Check / Adjust				● (2)
Fuel tank and strainer	Clean				● (2)
Combustion chamber	Clean		After every 300 hours (2)		
Fuel line	Check		Every 2 years (Replace if needed) (2)		

Notes:

● = Perform the task at the specified interval

★ = Replace only the paper element in the air cleaner

(1) = Service more frequently when used in dusty conditions

(2) = These tasks should be completed by a qualified service technician, unless you have the correct tools and are mechanically proficient.

Refueling

With the engine switched off, remove the fuel tank cap and check the fuel level. Refill the tank if needed.

⚠ WARNING – Petrol is highly flammable and explosive. You can be seriously injured or burned if fuel is mishandled.

MAXIMUM FUEL LEVEL

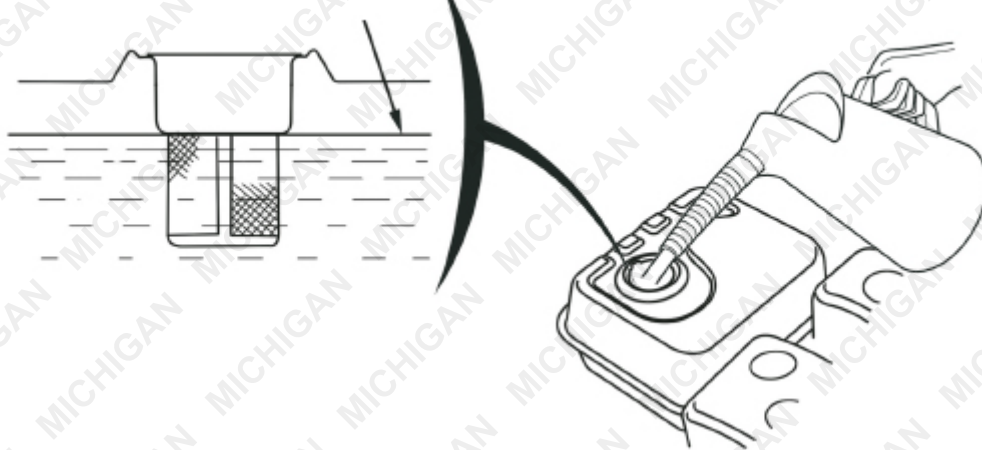

Safety Precautions:

- Stop the engine before refuelling.
- Handle fuel only outdoors in a well-ventilated area.
- Keep flames, sparks, heat sources, and lit items away (e.g. pilot lights, BBQs, electric tools).
- If the engine has been running, allow it to cool before refuelling.
- Do not overfill. Fill only up to the shoulder of the fuel strainer.
- Tighten the fuel cap securely after filling.
- Wipe up all spills immediately to reduce fire risk and environmental damage.
- ✗ Do not refuel indoors or near ignition sources.
- ✗ Do not store petrol in non-approved containers.

Note: Petrol can damage paint and plastic surfaces. Take care not to spill and wipe away any contact immediately. Damage caused by spilled fuel is not covered under warranty.

Fuel Recommendations

- Use unleaded petrol with an octane rating of 86 or higher.
- Do not use stale, dirty, or contaminated fuel, or oil/petrol mixtures.
- Unleaded fuel helps reduce deposits on spark plugs and prolongs exhaust system life.

Engine Knock (Pinging):

- Occasional light "pinging" under heavy load is normal.
- If persistent knock occurs during normal load, try a different brand of petrol.
- If the knocking continues, contact an authorised servicing dealer.

⚠ Prolonged operation with spark knock may cause engine damage. Damage caused by misuse (including running with persistent knocking) is not covered under warranty.

Engine Oil Level Check

Check the engine oil level with the engine stopped and positioned level.

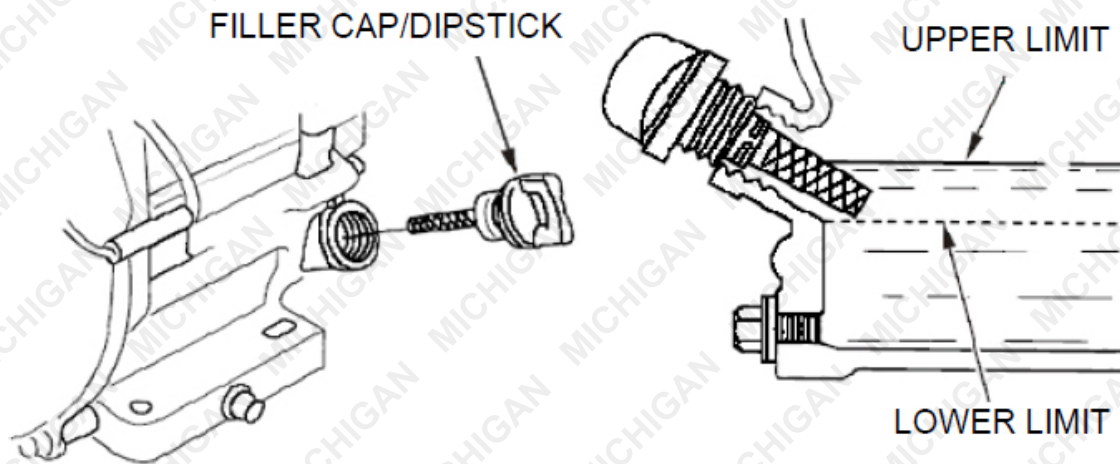

1. Remove the oil filler cap/dipstick and wipe it clean.
2. Insert and remove the dipstick without screwing it in.
3. Check the oil level indicated on the dipstick.
4. If the oil level is low, top up with the recommended engine oil until it reaches the top of the filler opening.
5. Reinstall and tighten the filler cap/dipstick securely.

Running the engine with low oil can cause severe damage.

Oil Alert System (If Equipped)

Some engine models include an Oil Alert system, which automatically shuts off the engine if the oil level drops below a safe limit.

- This protects the engine from damage.
- However, to avoid unexpected shutdowns, always check the oil level before each use.

Engine Oil Change

Tip: Drain the oil while the engine is warm. Warm oil flows out more quickly and thoroughly.

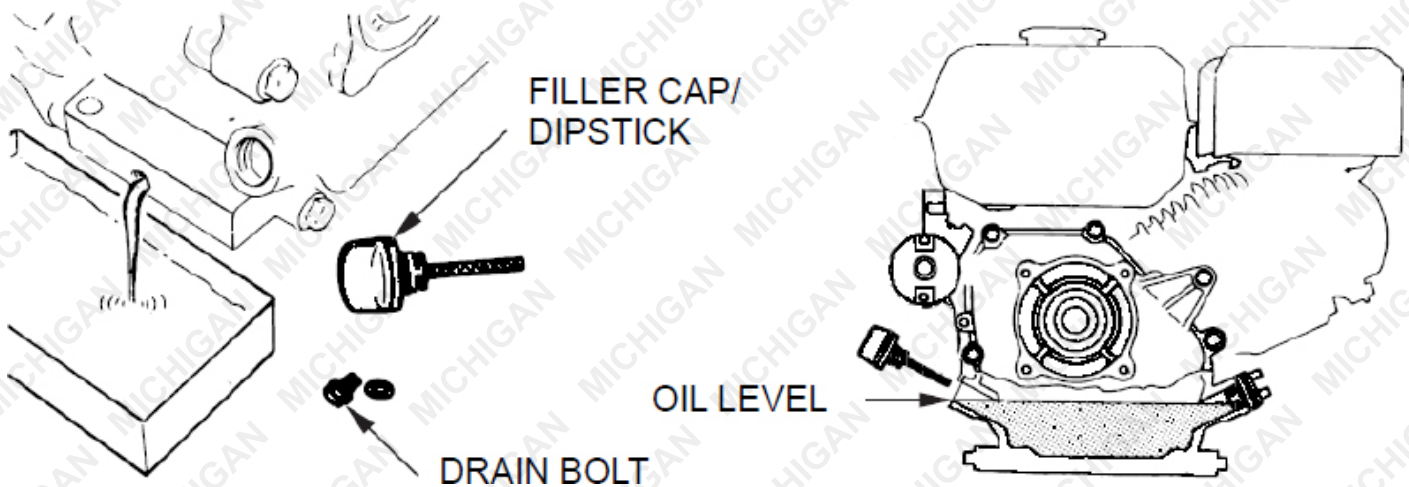

1. Place a suitable container beneath the engine to catch the used oil.
2. Remove the oil filler cap/dipstick and unscrew the oil drain plug.
3. Allow all oil to drain completely.
4. Reinstall the drain plug and tighten it securely.

♻️ Dispose of used oil responsibly. Do not pour used oil into drains, on the ground, or in general rubbish. Take it to a local recycling centre or service station for proper disposal in a sealed container.

5. With the engine level, refill using the recommended engine oil until it reaches the outer edge of the filler opening.
6. Screw in the filler cap/dipstick securely.

Important Notes:

- Running the engine with low oil can cause serious engine damage.
- On applicable models, the Oil Alert system will shut down the engine if oil drops below the safe level.
- To avoid unexpected shutdowns, always top up to the upper limit and check oil regularly.

Reduction Gear Oil

(Applicable to models equipped with ½ reduction and automatic centrifugal clutch)

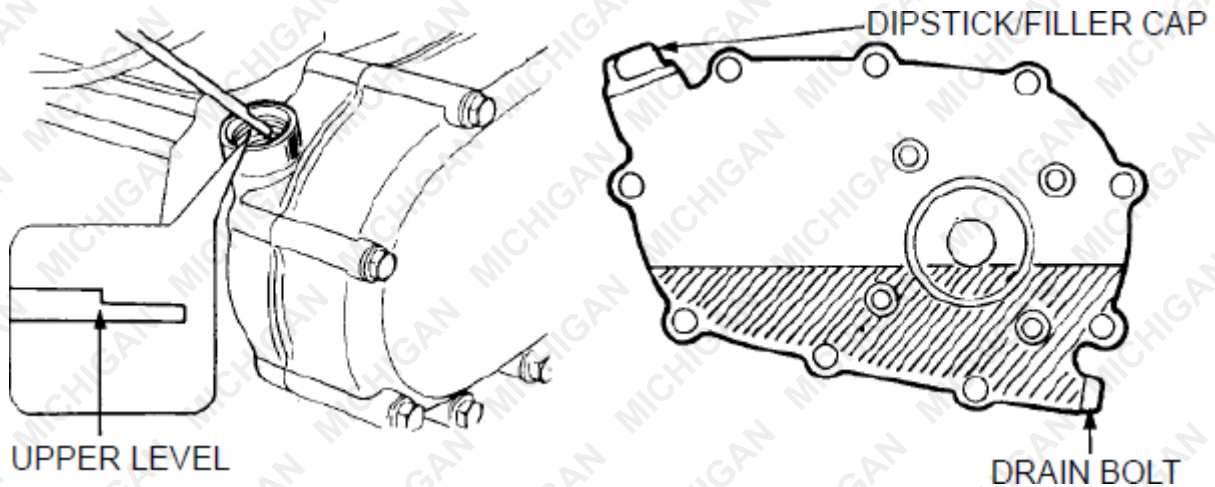

1. Remove the oil filler cap and wipe the dipstick clean.
2. Insert the dipstick into the filler neck without screwing it in.
3. If the oil level is below the upper mark, top up with the same oil recommended for the engine until the correct level is reached.

✓ Always use the correct oil type to ensure proper lubrication and prevent damage to the gear system.

Engine Oil Recommendations

Engine oil plays a critical role in overall performance and service life. Use a high-quality 4-stroke automotive detergent oil.

Recommended Oil: SAE 10W-30 is suitable for general, all-season use.

You may use other viscosities depending on the ambient temperature range in your area. Refer to the SAE viscosity chart in your engine manual for guidance.

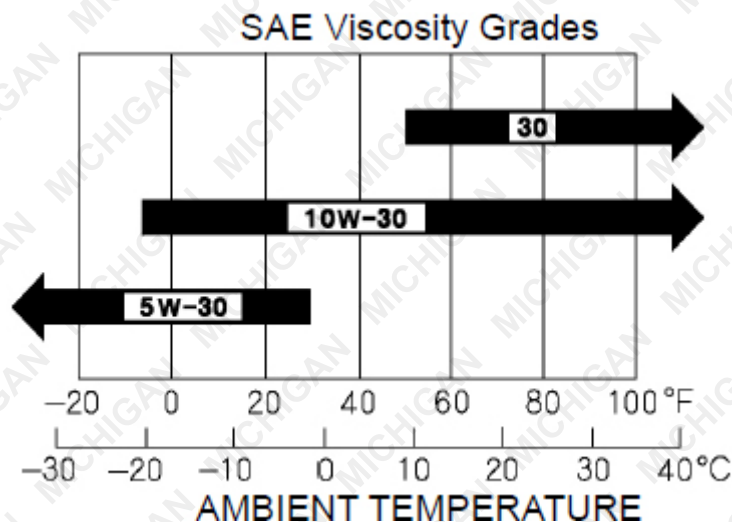

Raptor 1100 Wood Chipper

Oil Classification:

- Use oil that meets API Service Category SE, SF, or higher.
- This classification is shown on the API label on the oil container.

Always check the oil level regularly and change it at the recommended intervals to maintain optimal engine health.

Air Filter Inspection

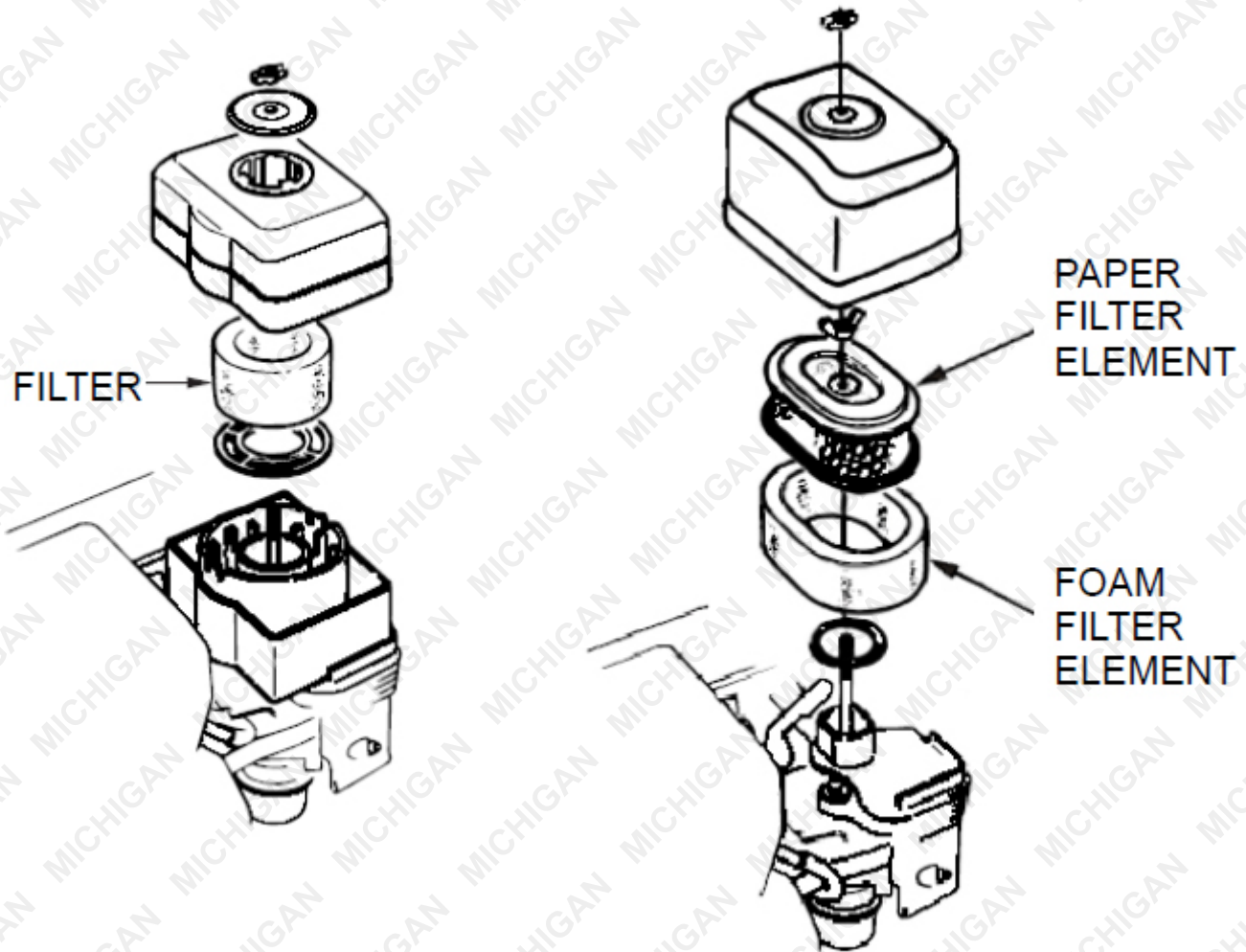

1. Remove the air cleaner cover to access the filter.
2. Inspect the filter element for dirt or damage:
 - Clean or replace dirty filter elements.
 - Always replace damaged filter elements.

If your unit is fitted with an oil-bath air cleaner, also check and top up the oil level as needed.

Operating the engine with a dirty or damaged air filter can reduce performance and cause premature engine wear.

Air Cleaner Service

- A dirty air filter restricts airflow to the carburettor, reducing engine performance.
- If operating in very dusty environments, clean the air filter more frequently than stated in the Maintenance Schedule.

⚠ Note: Running the engine without a filter—or with a damaged one—can allow dirt to enter the engine, causing rapid wear. This type of damage is not covered by the Distributor's Limited Warranty.

Dual-Element Air Cleaner

1. Remove the wing nut and take off the air cleaner cover.
2. Remove the air filter wing nut, then remove the complete filter.
3. Separate the foam element from the paper element.
4. Inspect both filters:
 - Replace if damaged.
 - Always replace the paper filter at the scheduled interval.
5. Clean reusable elements as follows:

Paper Filter:

- Tap gently on a hard surface to remove debris, or
- Blow compressed air (max 207 kPa / 30 psi) from the inside out.
- Do not brush—this forces dirt deeper into the fibres.

Foam Filter:

- Wash with warm soapy water, rinse, and let dry completely;
- or clean with non-flammable solvent, then dry thoroughly.
- Lightly coat with clean engine oil, then squeeze out all excess oil.
Excess oil will cause the engine to smoke on startup.

6. Wipe dirt from the base and inside of the air cleaner cover using a damp cloth. Avoid letting dirt enter the carburettor intake.
7. Reassemble the filters, placing the foam element over the paper element. Ensure the gasket is in place under the filter. Tighten the filter wing nut securely.
8. Refit the air cleaner cover and tighten the cover wing nut.

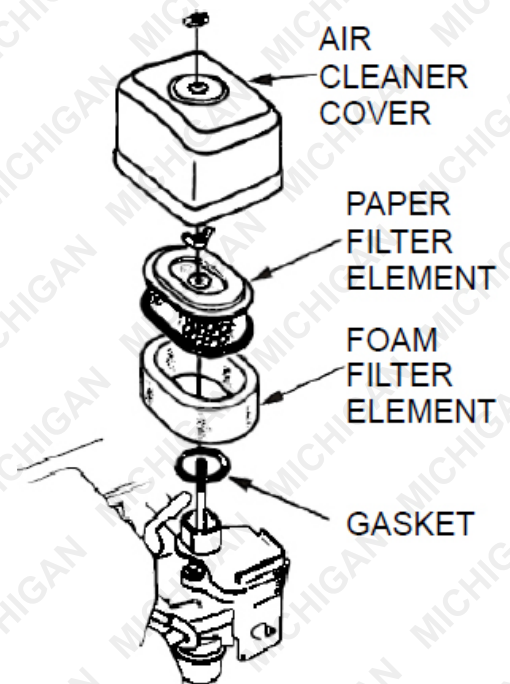

Oil-Bath Type Air Cleaner (If Equipped)

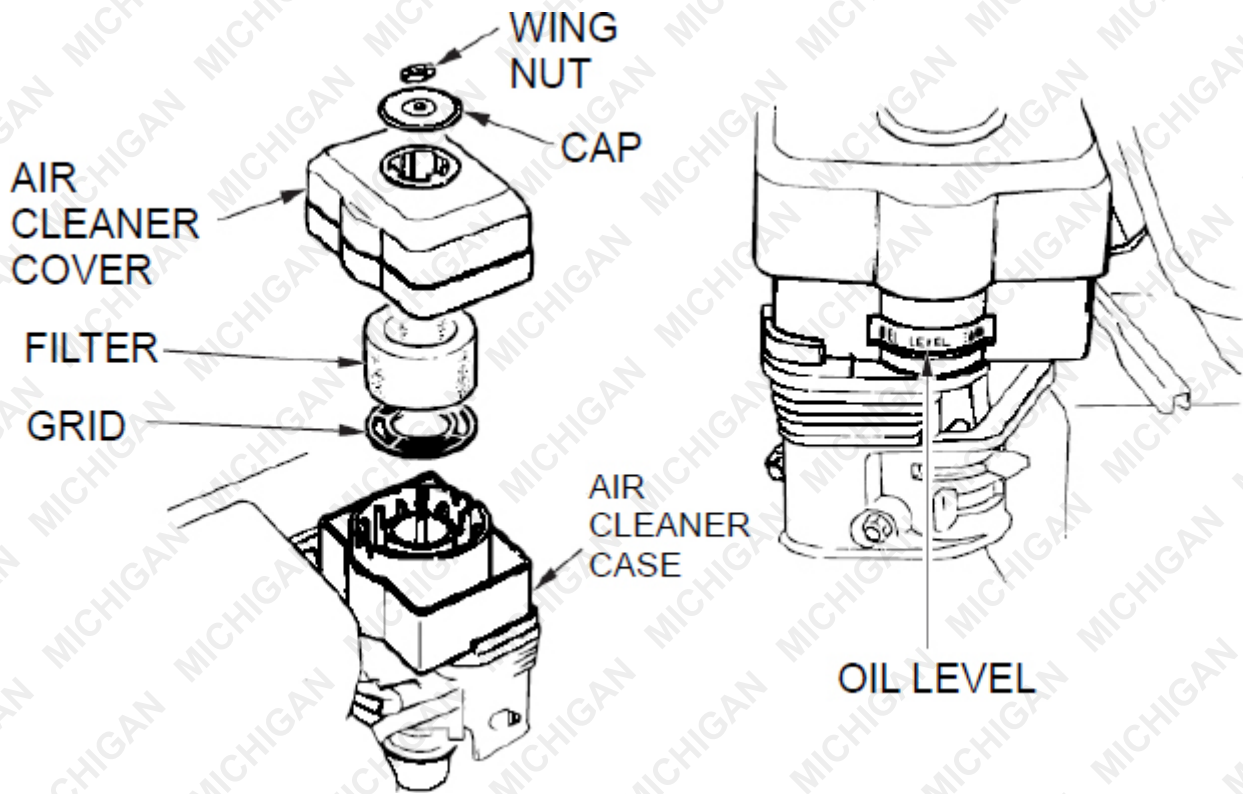

1. Remove the wing nut, air cleaner cap, and cover.
2. Remove the filter from the cover. Wash both filter and cover in warm, soapy water, rinse, and dry thoroughly, or clean with non-flammable solvent.
3. Dip the filter in clean engine oil, then squeeze out excess oil.
Too much oil will cause the engine to smoke at startup.
4. Empty used oil from the cleaner case. Wash out dirt with solvent and dry.
5. Refill with engine oil to the OIL LEVEL mark (capacity: 60 mL / 2.0 US oz).
6. Reassemble the cleaner and tighten the wing nut securely.

Sediment Cup Cleaning

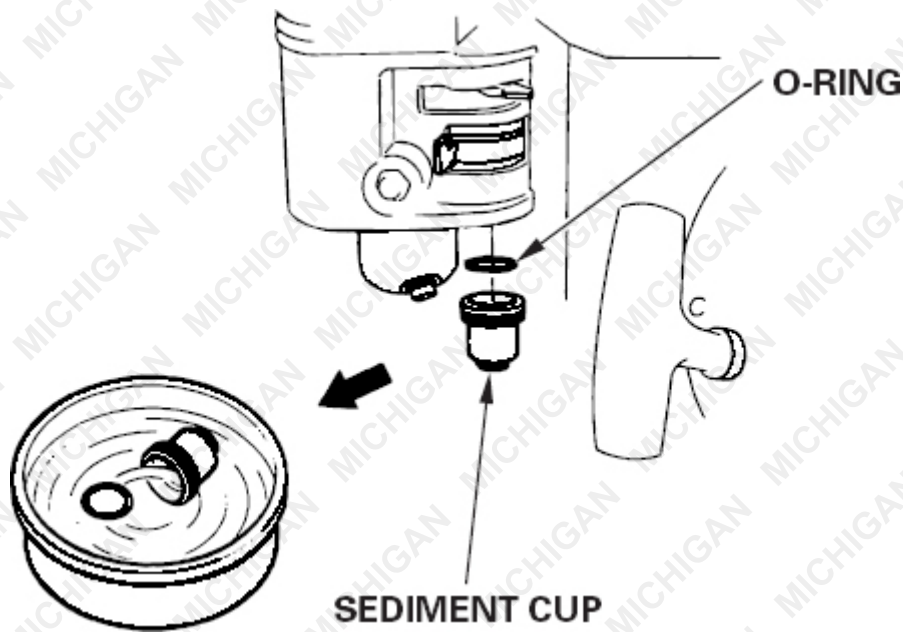

Over time, fuel contaminants can collect in the sediment cup. Periodic cleaning helps maintain proper fuel flow and engine performance.

1. Turn the fuel valve to the OFF position.
2. Carefully remove the sediment cup and O-ring from the fuel valve.

⚠ Warning – Petrol is highly flammable and explosive. You can be seriously injured or burned if mishandled. Keep heat, flames, and sparks away. Always handle fuel outdoors in a well-ventilated area. Wipe up spills immediately.

3. Clean the sediment cup and O-ring using a non-flammable solvent, then dry them thoroughly.
4. Place the O-ring back into the fuel valve, then reinstall and tighten the sediment cup securely.
5. Turn the fuel valve to the ON position and check for leaks.

🔧 If any fuel leakage is detected, replace the O-ring before operating the engine.

Spark Plug Service

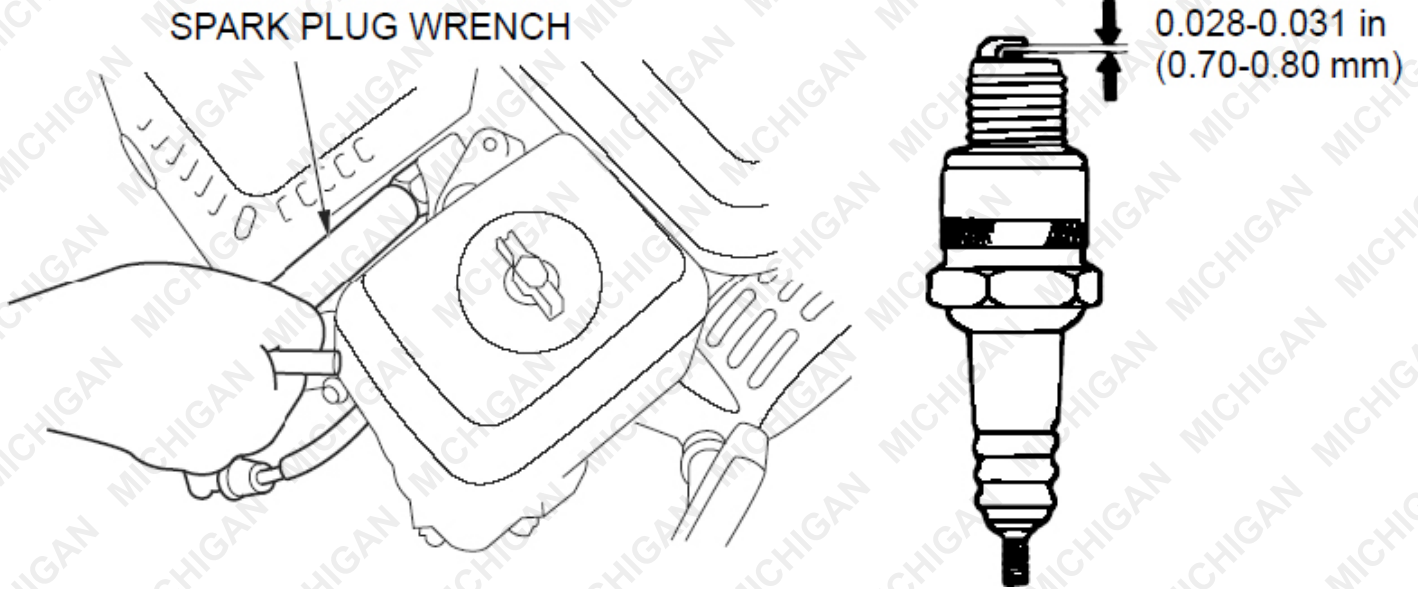

Recommended spark plug: F7RTC or equivalent

⚠ Note: Using an incorrect spark plug can cause engine damage.

1. Disconnect the spark plug cap and clean any dirt or debris from around the spark plug area.
2. Remove the spark plug using a spark plug wrench.
3. Inspect the spark plug:
 - Replace it if the electrodes are worn.
 - Replace if the ceramic insulator is cracked or chipped.
4. Check the electrode gap with a feeler gauge:
 - The correct gap is 0.70–0.80 mm (0.028–0.031 in).
 - Adjust if necessary by carefully bending the side electrode.
5. Install the spark plug by hand to avoid cross-threading.
6. Once seated:
 - If reusing a spark plug, tighten $\frac{1}{4}$ turn with a wrench.
 - If installing a new spark plug, tighten $\frac{1}{2}$ turn with a wrench.

⚠ Note: A loose spark plug can cause overheating and engine damage. Over-tightening can strip the threads in the cylinder head.

7. Reconnect the spark plug cap securely.

Idle Speed Adjustment

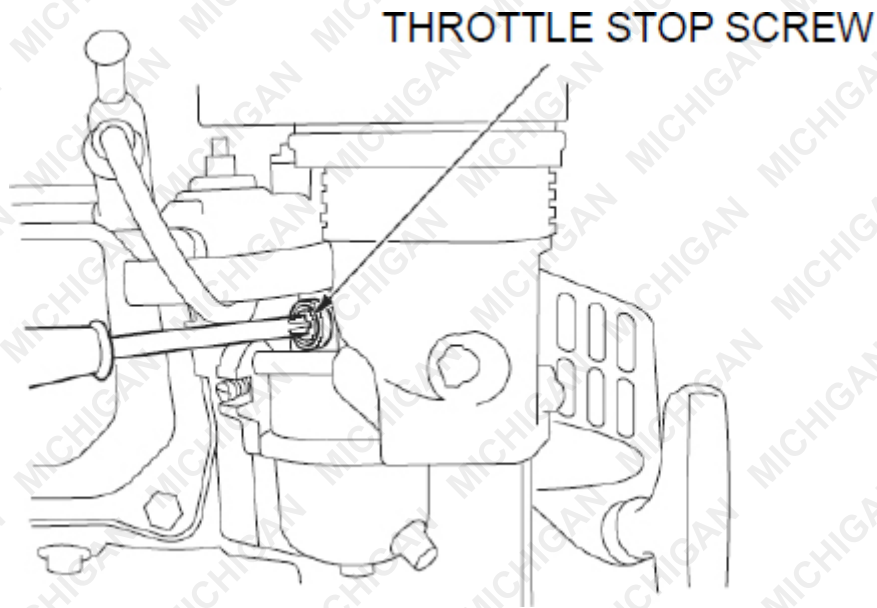

1. Start the engine outdoors and allow it to warm up to normal operating temperature.
2. Move the throttle lever to the SLOW position (lowest speed).
3. Turn the throttle stop screw slowly to set the idle speed.

 **Standard idle speed: 1800 ± 150 rpm**

Use a tachometer for accurate adjustment if available.

Spark Arrester Service (Optional Equipment)

Your engine is not factory-fitted with a spark arrester. In some areas, especially bushfire-prone regions, it is illegal to operate an engine without one.

Check your local laws and regulations. Spark arresters are available through authorised servicing dealers.

 **WARNING: Never operate the engine in forested or fire-prone areas without a properly functioning spark arrester. Doing so may cause a fire.**

Service Interval

- Clean and inspect the spark arrester every 100 hours of operation to ensure it functions correctly.

Servicing Procedure

⚠ Allow the muffler to cool completely before servicing, as it can remain hot after engine shutdown.

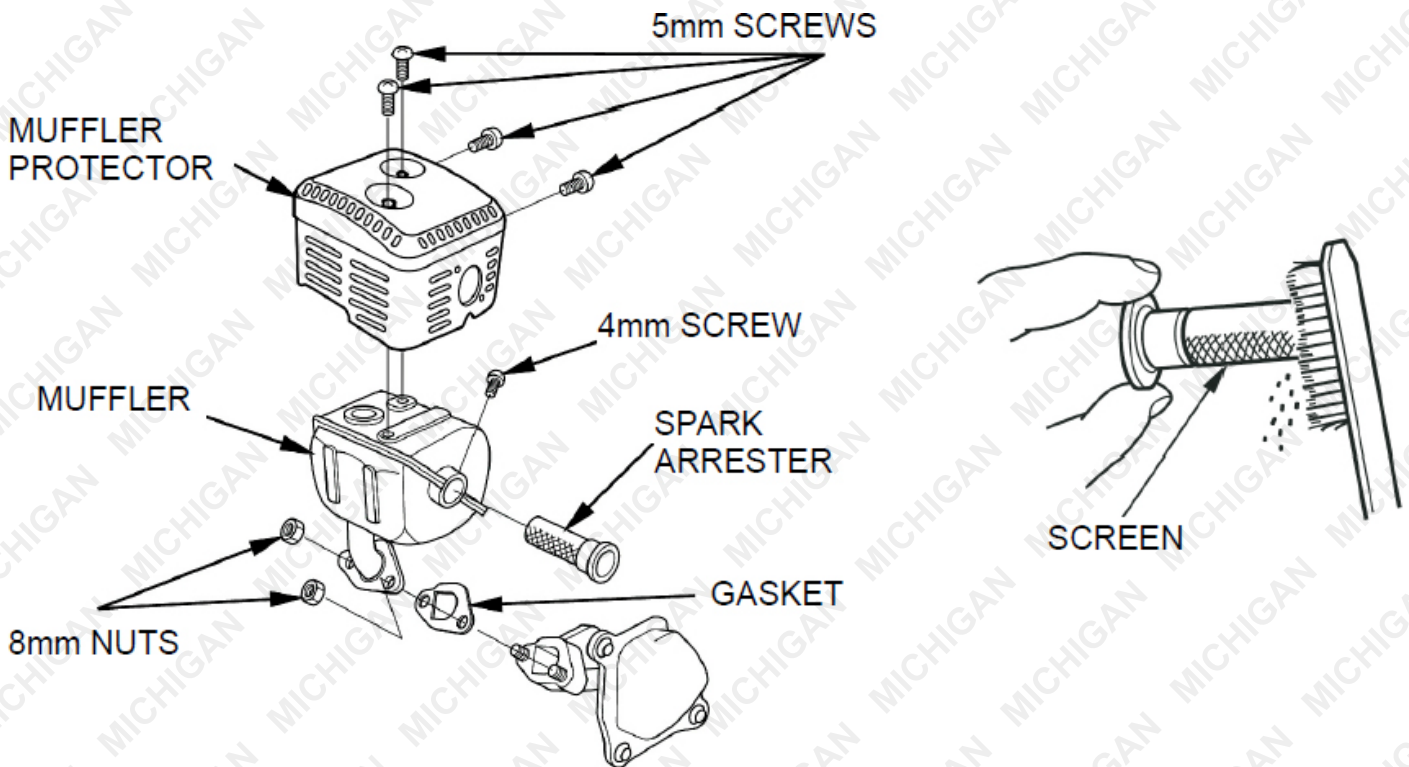

1. Remove the three 4 mm screws from the exhaust deflector and take off the deflector.
2. Remove the four 5 mm screws securing the muffler protector and remove the protector.
3. Remove the 4 mm screw securing the spark arrester, then carefully remove the spark arrester from the muffler.
4. Use a soft wire brush to clean carbon deposits from the arrester screen.
 - Do not damage or puncture the screen.
 - Replace the spark arrester if it shows holes, breaks, or wear.
5. Reinstall the spark arrester, muffler protector, and exhaust deflector in reverse order.

Storage

If your chipper will not be used for 30 days or more, follow these steps to properly prepare it for storage and prevent damage:

1. Drain the Fuel Tank

- Empty the fuel tank completely.
- Stale fuel can form gum deposits that clog the carburetor and restrict fuel flow.

2. Run the Engine Dry

- Start the engine and let it run until it stops.
- This clears any remaining fuel from the carburetor and prevents internal deposit build-up.

3. Change the Engine Oil

- While the engine is still warm, drain the oil.
- Refill with fresh oil.

4. Lubricate the Cylinder

- Allow the engine to cool completely.
- Remove the spark plug and pour 60 ml of SAE-30 high-quality engine oil into the cylinder.
- Slowly pull the starter cord a few times to distribute the oil, then reinstall the spark plug.

⚠ Important: Before restarting after storage, remove the spark plug and drain all oil from the cylinder to avoid damage.

5. Clean the Unit

- Wipe down the chipper with a clean cloth.
- Keep air vents clear and free from debris.

✘ Do not use strong detergents or petroleum-based cleaners on plastic parts, as they can cause damage.

6. Store Safely

- Store the chipper in an upright position in a clean, dry, and well-ventilated area.
- Do not store the machine with fuel in an enclosed space where vapours could reach sparks, flames, or pilot lights.
- Use only approved fuel containers.

7. Secure the Unit

- For added safety during storage, bolt the chipper to the ground as shown in the illustration to the right.

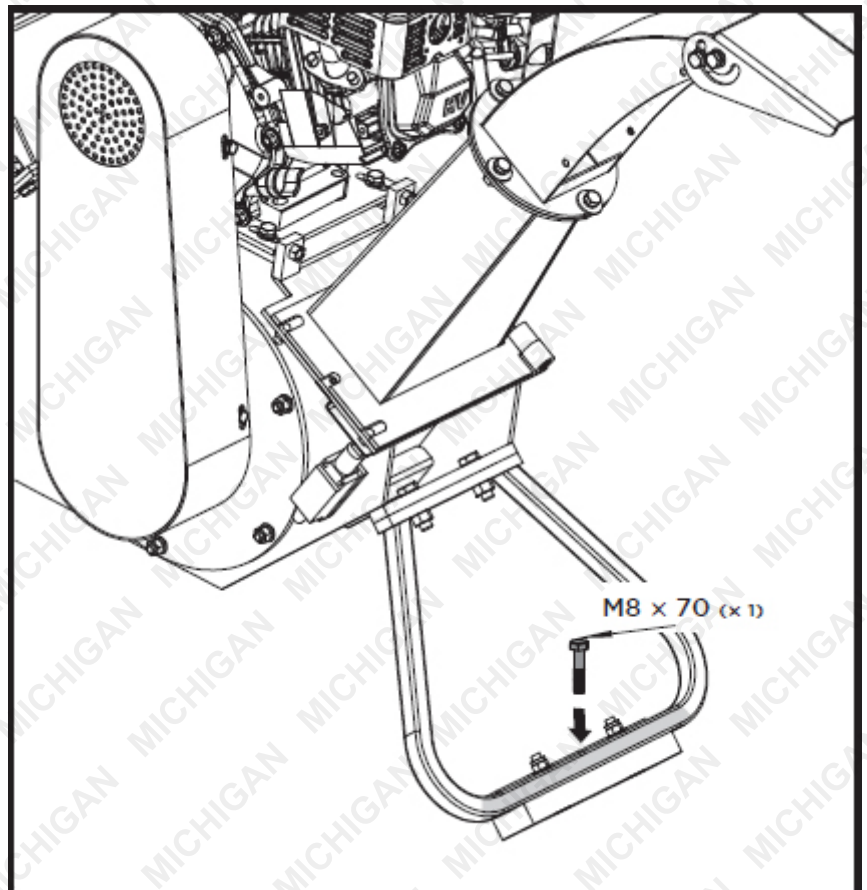

Troubleshooting

✘ Engine Fails to Start

Possible Cause	Remedy
Spark plug wire is disconnected	Attach spark plug wire securely to spark plug
Out of fuel or stale fuel	Fill with clean, fresh petrol
Engine and/or fuel valve not in ON position	Ensure both are switched ON
Choke lever is not in CLOSED position	Set choke to CLOSED for cold starts
Blocked fuel line	Clean the fuel line
Fouled spark plug	Clean, adjust gap, or replace plug
Engine flooded	Wait a few minutes before restarting (do not prime)
Belt tension lever is engaged	Disengage the belt tension lever

⚠ Engine Runs Erratically

Possible Cause	Remedy
Spark plug wire is loose	Connect and tighten spark plug wire
Choke lever in CLOSED position during operation	Move choke lever to OPEN
Blocked fuel line or stale fuel	Clean line and refill with fresh petrol
Vent plugged	Clear the vent
Water or dirt in fuel system	Drain fuel tank and refill with clean fuel
Dirty air cleaner	Clean or replace air cleaner
Improper carburettor adjustment	Adjust carburettor

🔥 Engine Overheats

Possible Cause	Remedy
Engine oil level low	Fill with correct grade oil
Dirty air cleaner	Clean or replace air cleaner
Restricted air flow	Remove housing and clean thoroughly
Carburettor not adjusted properly	Adjust carburettor

Chipping Action Is Too Slow / No Material Is Discharged

Possible Cause	Remedy
Engine running too slow, causing belt slip	Run the engine at full throttle
Drive belt is loose or damaged	Tighten or replace belt
Knives are dull or damaged	Sharpen or replace knives
Cutting disc jammed with debris	Clear debris and manually turn disc with a wooden stick to free it
Discharge chute is clogged	Clean out all debris from chute

The belt frays or rolls over the pulley

Possible Cause	Remedy
Rotor drive pulley groove is nicked	Check belts for wear or hard spots. File off any nicks on the pulley
Drive belts are stretched	Replace the drive belts
Pulleys are misaligned	Adjust pulley alignment for proper tracking

Branches vibrate excessively or make unusual noise during chipping

Possible Cause	Remedy
Knives are dull or damaged	Sharpen or replace the knives
Knives not properly seated on cutting disc	Loosen, reposition, and retighten the knife mounting screws
Knife-to-wear plate gap is too large	Adjust the gap to correct clearance
Rotor overloaded with material	Allow machine to clear itself before feeding more material

Chipper knives are hitting the wear plate

Possible Cause	Remedy
Knife-to-wear plate gap is set incorrectly	Adjust the gap to proper clearance

Machine tracks left or right while being towed

Possible Cause	Remedy
Tyre pressure is uneven or low	Inflate tyres evenly to the correct pressure



Specifications

Power Type	Petrol
Engine Displacement	212cc
Engine Type	Air Cooled 4-Stroke Euro V
Starting System	Recoil
Fuel Capacity	3.6L
Fuel Type	Petrol Regular Unleaded 95+ RON
Oil Capacity	0.6L
Engine Oil Type	10W-30, 10W-40, 15W-30 OR 15W-40 non-synthetic engine oil <i>(not included with purchase)</i>
Blade Speed	2400RPM
Wheels	10 x 4.1 inch pneumatic
Max branch diameter	Refer to the product listing

Please note: This model is not designed for tough fibrous material, such as flax, vines or palm fronds. Assembly Required



Some experts believe that the incorrect or prolonged use of almost any product may cause serious injury or death. To help reduce your risk of serious injury or death, refer to the information below. For more information, see www.datastreamserver.com/safety

- Consult all documentation, packaging, and product labelling before use. Note that some products feature documentation available online. It is recommended to print and retain the documentation.
- Before each use, check the product for loose/broken/damaged/missing parts, wear, or leaks (if applicable). Never use a product with loose/broken/damaged/missing parts, wear, or leaks.
- Products must be inspected and serviced (if applicable) by a qualified technician every 6 months. This is based on average residential use by persons of average size and strength, and on a property of average metropolitan size. Use beyond these recommendations may require more frequent inspections/servicing.
- Ensure that all users of the product have completed a suitable industry recognised training course before being allowed access to the product.
- The product has been supplied by a general merchandise retailer that may not be familiar with your specific application or description of application. Be sure to attain third-party approval from a qualified specialist for your application before use, regardless of any assurances from the retailer or its representatives.
- This product is not intended for use where fail-safe operation is required. As with any product (for example, automobile, computer, toaster), there is the possibility of technical issues that may require the repair or replacement of parts, or the product itself. If the possibility of such failure and the associated time it may take to rectify could in any way inconvenience the user, business, or employee, or financially affect the user, business, or employee, then the product is not suitable for your requirements. This product is not intended for use where incorrect operation or a failure of any kind, including but not limited to, a condition requiring product return, replacement, parts replacement, or service by a technician may cause financial loss, loss of employee time or an inconvenience requiring compensation.
- If this product has been purchased in error when considering the information presented here, contact the retailer directly for details of their returns policy, if required.

