

DESKY

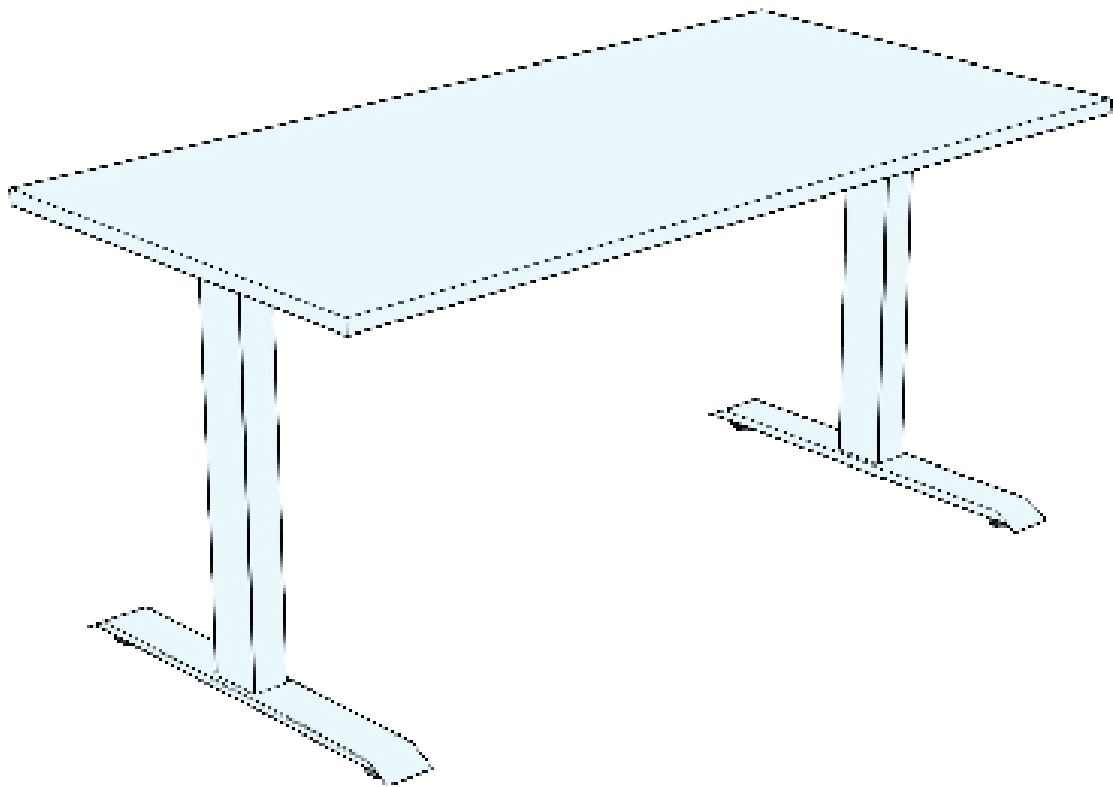

DESKY ZERO FIXED OFFICE DESK INSTRUCTION MANUAL

DESKY

CONTENTS

Parts List & Tools	3
Components Diagram	4
Assembly Instructions	5

DESKY

PARTS LIST & TOOLS

BOX 1

A - CROSSBAR ENDS
QTY: 2

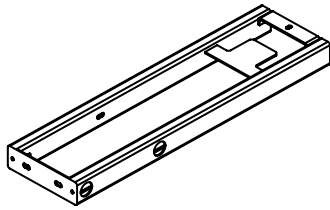

B - CROSSBAR RAILS
QTY: 2

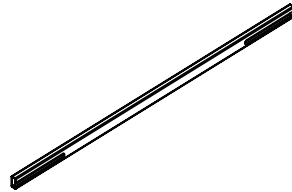

C - SIDE BRACKETS
QTY: 2

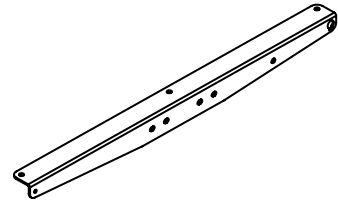

D - FOOT
QTY: 2

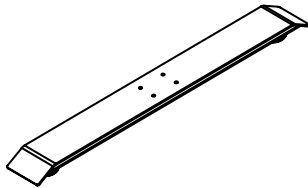

E - HEX KEY
QTY: 2

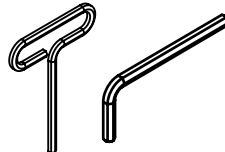

F - MACHINE SCREWS
QTY: 38 - M6x14



G - GRUB SCREWS
QTY: 8



H - TIMBER SCREWS
QTY: 14



I - CABLE CLIPS
QTY: 10

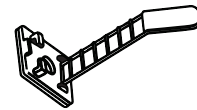

BOX 2

J - LEGS
QTY: 2

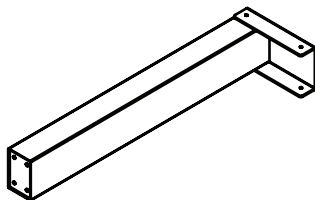

DESKY

COMPONENTS DIAGRAM

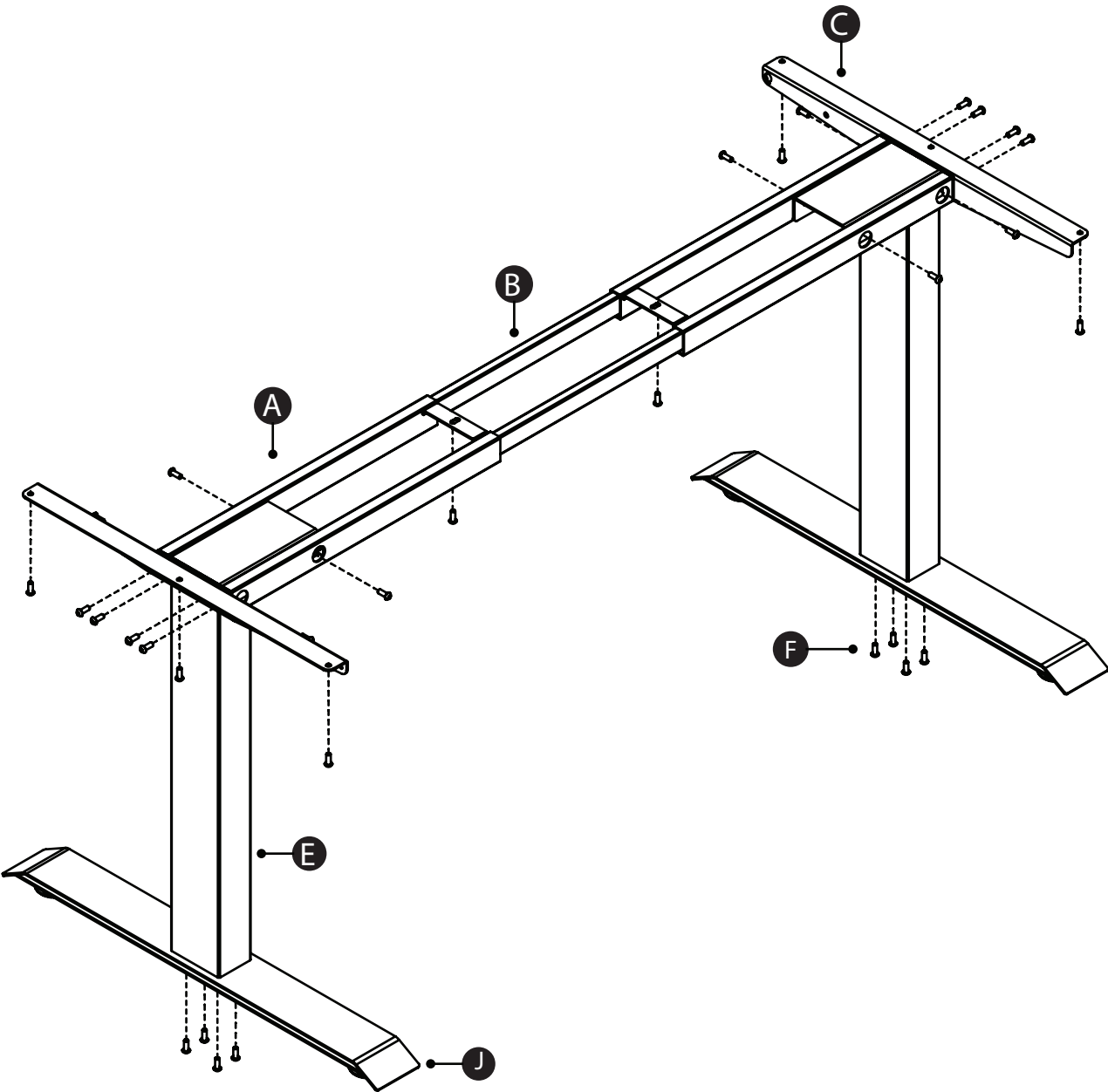

DESKY

ASSEMBLY INSTRUCTIONS

STEP 1

Place the two Crossbar ends (A) upside down so that the eight (8) machine grub screws (G) are facing upward as pictured. Loosen the grub screws so the two ends can be separated.

The Crossbar rails (B) are located inside the Crossbar ends (A) and will need to be removed and set aside for later steps.

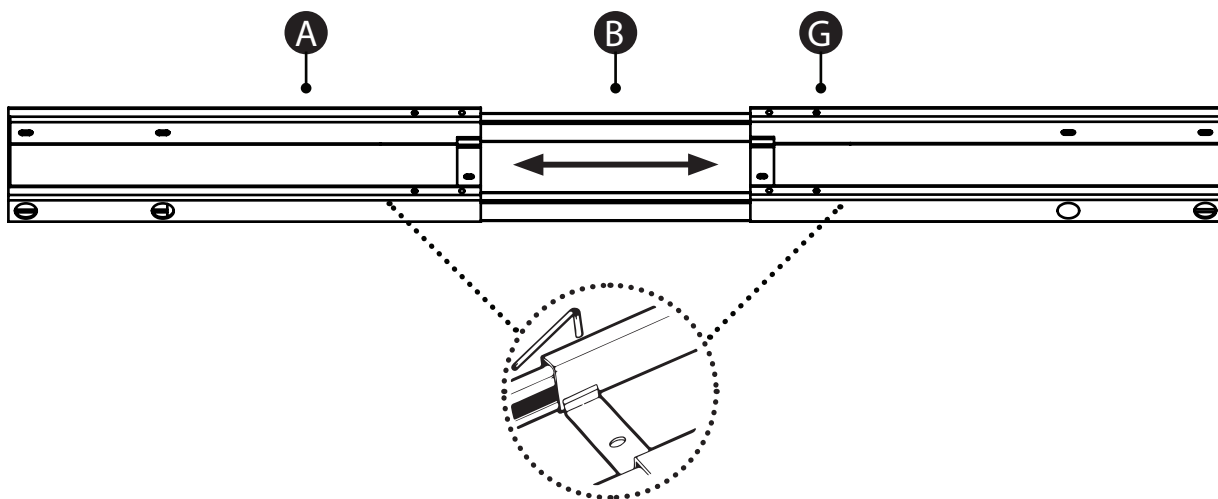

STEP 2

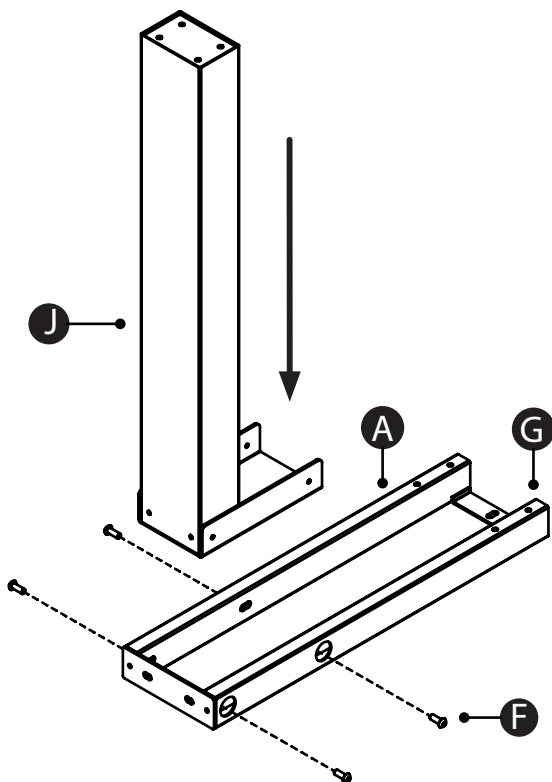

Place the Crossbar end (A) upside down as pictured and insert the leg (J) so that the four (4) holes in the leg line up with the 4 holes on the crossbar end.

Ensure that the Crossbar end is orientated so that the machine grub screws (G) face upward when inserting the leg.

Insert four (4) Machine screws (F) and use the Hex key (E) to scew in a few turns. Do not tighten completely.

Repeat this step for the second leg.

DESKY

ASSEMBLY INSTRUCTIONS

STEP 3

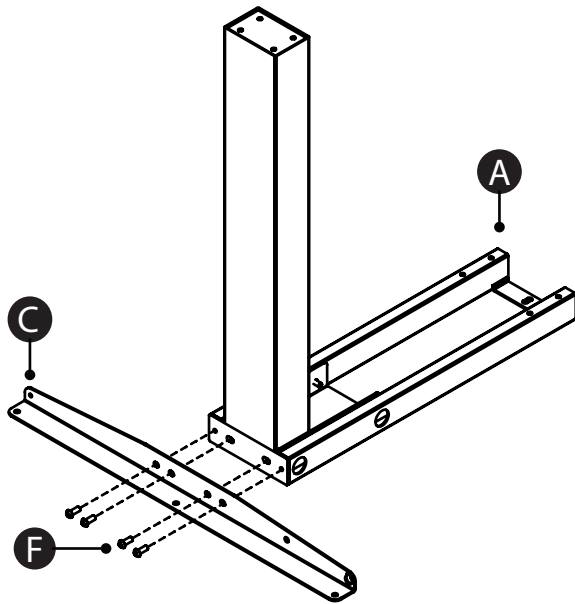

Position the Side bracket (C) against the back of the Crossbar end (A) so that the four (4) holes in the side bracket line up with the holes on the crossbar end.

Insert four (4) Machine screws (F) and use the large Hex key (E) to screw in a few turns. Do not tighten completely. Start with the two outside screws first.

Repeat this step for the second leg.

Now tighten all the Machine screws (F) from Steps 2 and 3.

STEP 4

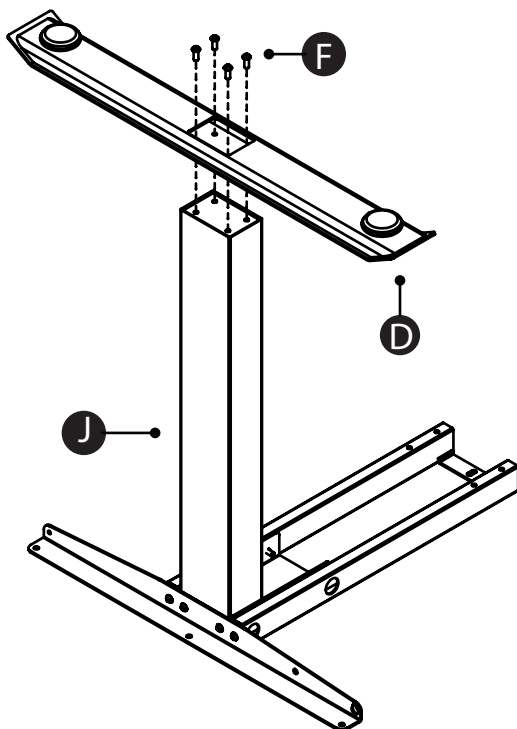

Place the Foot (D) onto the leg (J) as shown so that the four holes in each line up.

Insert four (4) Machine screws (F) and use the large Hex key (E) to screw in a few turns. Once all four screws have been started, tighten completely.

Repeat this step for the second foot.

Round levelling feet/ studs are attached to each foot to assist with levelling the desk.

DESKY

ASSEMBLY INSTRUCTIONS

STEP 5

Slide the two Crossbar rails (B) into the two Crossbar ends (A) to connect the frame assembly. Ensure the crossbar rails are orientated so the rail cut-outs face inward as shown.

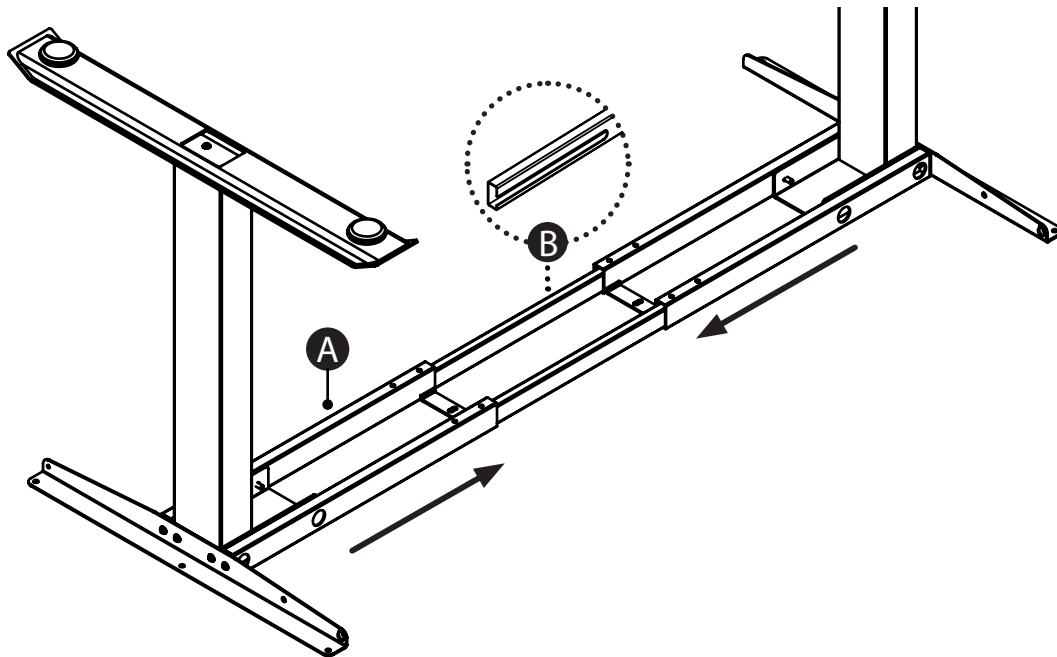

STEP 6

Place your desktop upside down on a non-abrasive surface like a carpet or rug and place the frame on top. Adjust the width of the frame by pulling the two halves apart to line up with the pre-drilled holes or threaded screw inserts in the desktop.

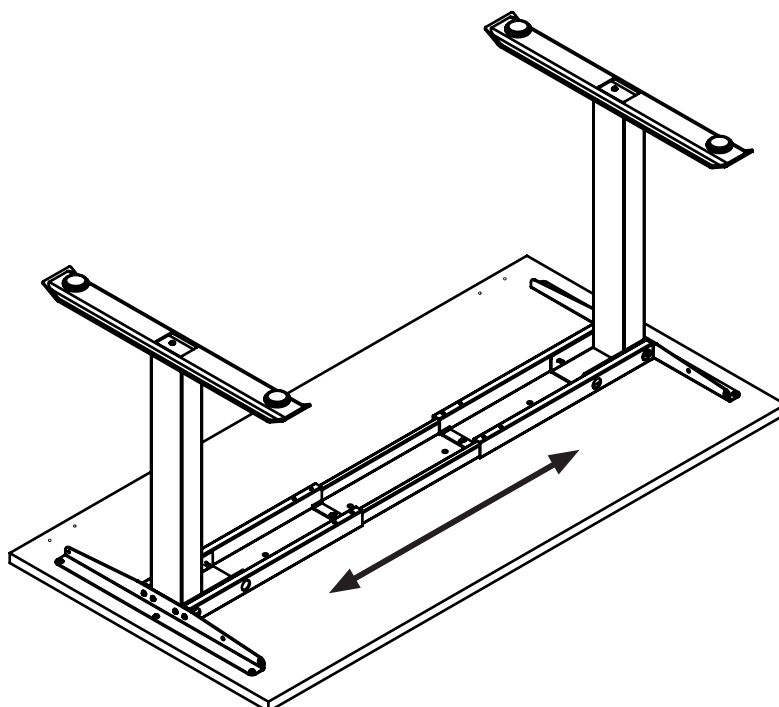

DESKY

ASSEMBLY INSTRUCTIONS

STEP 7

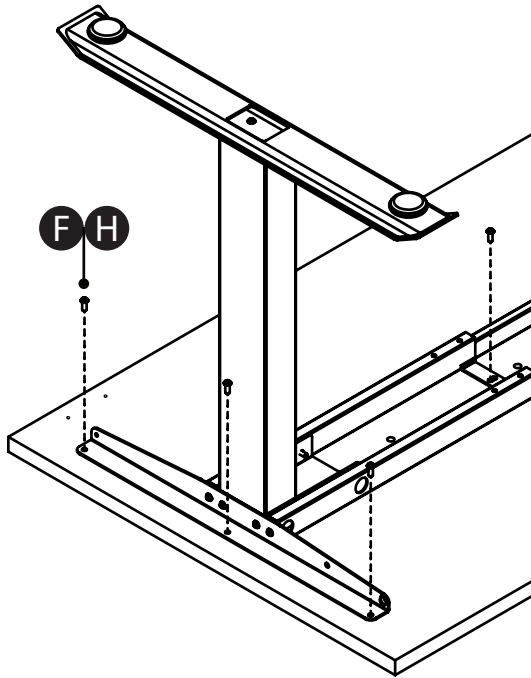

Your desktop will have pre-drilled holes or threaded screw inserts, depending on the desktop you have purchased from us.

Desktops with threaded screw inserts: use eight (8) Machine screws (F) to secure the frame to the desktop.

Desktops with pre-drilled holes: use eight (8) Timber screws (H) to secure the frame to the desktop.

Insert all screws and tighten loosely. Once all eight screws are in, tighten the frame to the desktop completely.

If your desktop does not have threaded screw inserts or pre-drilled holes you will need to pull the frame apart to position each leg assembly close to the edge of the desk. If you have also purchased the Integrated Cable & Power Channel you will need to make sure the frame is not too wide to attach the channel between the Side brackets (C).

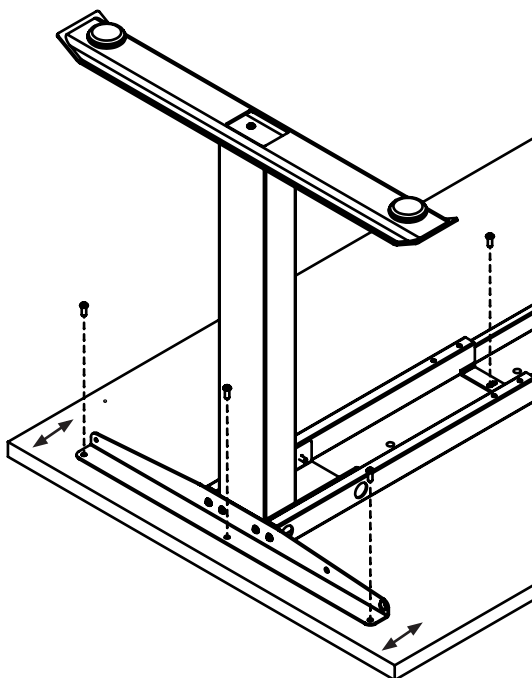

To position the frame in this instance we recommend using the guide below to measure the minimum distance between the edge of your desk and screw holes in the side brackets.

1200mm length desktop - 25mm
1500mm length desktop - 50mm
1800mm length desktop - 80mm

Use eight (8) Timber screws M5 (H) to secure the frame to the desktop.

DESKY

ASSEMBLY INSTRUCTIONS

STEP 8

Use the Hex key (E) provided to insert and tighten each Grub screw (G) on the Crossbar ends (A) and secure the Crossbar rails (B) in place.

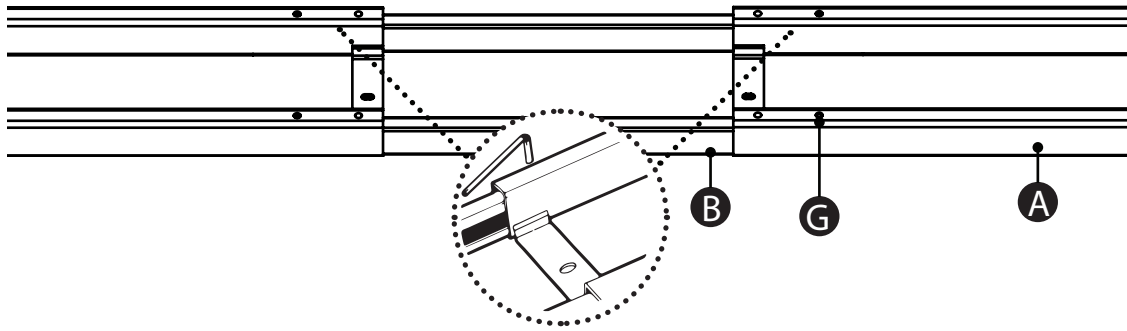

STEP 9

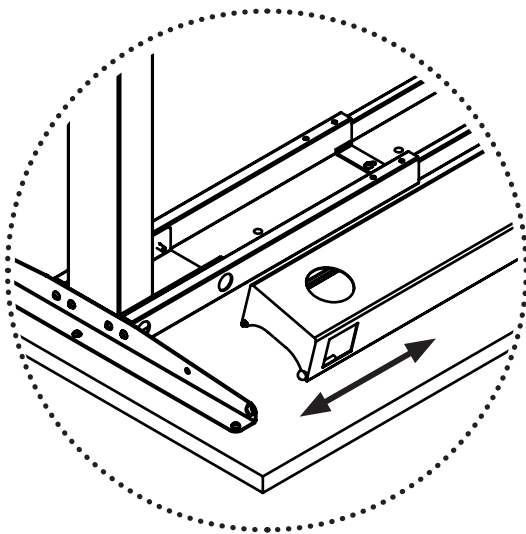

If you have purchased the Integrated Cable & Power Channel, secure one end to the Side bracket (C) as shown and extend the width of the channel to meet the other side bracket.

Make sure the spring release knob is screwed into the side bracket securely.

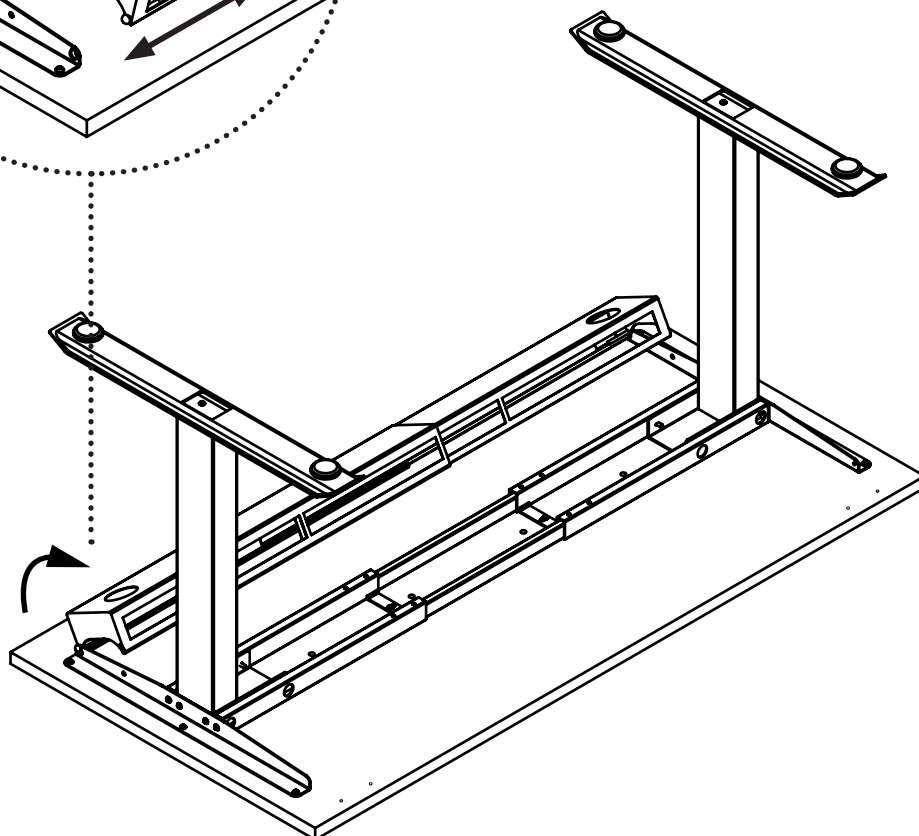



DESKY