

POLYCOOL®

MSL-600 TWIN TANK 6L SLUSH MACHINE



User Manual

[Revision 2.0]

READ THIS MANUAL CAREFULLY BEFORE USE – FAILURE TO DO SO MAY RESULT IN INJURY, PROPERTY DAMAGE AND MAY VOID WARRANTY. • KEEP THIS MANUAL FOR FUTURE REFERENCE. • Products covered by this manual may vary in appearance, assembly, inclusions, specifications, description, and packaging.

Safety

Safety messages are designed to alert you to possible dangers or hazards that could cause death, injury or equipment or property damage if not understood or followed. Safety messages have the following symbols:



You **WILL** be **KILLED** or **SERIOUSLY INJURED** if you do not follow instructions.



You **CAN** be **KILLED** or **SERIOUSLY INJURED** if you do not follow instructions.



You **CAN** be **INJURED** if you do not follow instructions or equipment damage may occur.

It is vital that you read and understand this user manual before using the product, including safety warnings, and any assembly and operating instructions. Keep the manual for future reference.

Safety precautions and recommendations detailed here must be fully understood and followed to reduce the risk of injury, fire, explosion, electrical hazard, and/or property damage.

Safety information presented here is generic in nature – some advice may not be applicable to every product. The term "equipment" refers to the product, be it electrical mains powered, battery powered or combustion engine powered.

- **Before Use** - If you are not familiar with the safe operation/handling of the equipment or are in any way unsure of any aspect of suitability or correct use for your application, you should complete training conducted by a person or organization qualified in safe use and operation of this equipment, including fuel/electrical handling and safety.
- Do NOT operate the equipment in flammable or explosive environments, such as in the presence of flammable liquids, gases, or dust. The equipment may create sparks or heat that may ignite flammable substances.
- Keep clear of moving parts.
- Equipment may be a potential source of electric shock or injury if misused.
- Do NOT operate the equipment if it is damaged, malfunctioning or is in an excessively worn state.
- Do NOT allow others to use the equipment unless they have read this manual and are adequately trained.
- Keep packaging away from children - risk of suffocation! Operators must use the equipment correctly. When using the equipment, consider conditions and pay due care to persons and property.

General Work Area Safety

- Work areas should be clean and well lit.
- Do not operate the equipment if bystanders, animals etc are within operating range of the equipment or the general work area.
- If devices are provided for connecting dust extraction / collection facilities, ensure these are connected and used properly. Dust collection can reduce dust-related hazards.

General Personal Safety

- Wear appropriate protective equipment when operating, servicing, or when in the operating area of the equipment to help protect from eye and ear injury, poisoning, burns, cutting and crush injuries. Protective equipment such as safety goggles, respirators, non-slip safety footwear, hard hat, hearing protection etc should be used for appropriate equipment / conditions. Other people nearby should also wear appropriate personal protective equipment. Do not wear loose clothing or jewellery, which can be caught in moving parts. Keep hair and clothing away from the equipment.
- Stay alert and use common sense when operating the equipment. Do not over-reach. Always maintain secure footing and balance.
- Do not use the equipment if tired or under the influence of drugs, alcohol, or medication.
- This equipment is not intended for use by persons with reduced physical, sensory, or mental capabilities.

General Fuel Safety

- Petrol/fuel/gasoline is extremely flammable – keep clear of naked flames or other ignition sources.
- Do not spill fuel. If you spill fuel, wipe it off the equipment immediately – if fuel gets on your clothing, change clothing.
- Do NOT smoke near fuel or when refuelling.
- Always shut off the engine before refuelling.
- Do NOT refuel a hot engine.
- Open the fuel cap carefully to allow any pressure build-up in the tank to release slowly.
- Always refuel in well-ventilated areas.
- Always check for fuel leakage. If fuel leakage is found, do not start, or run the engine until all leaks are fixed.

General Carbon-Monoxide Safety

- Using a combustion engine indoors **CAN KILL IN MINUTES**. Engine exhaust contains carbon-monoxide – a poison you cannot smell or see.
- Use combustion engines **OUTSIDE** only, and far away from windows, doors, and vents.

General Equipment Use and Care

- Keep packaging away from children and pets, potential risk of suffocation or choking.
- The equipment is designed for domestic use only.
- Handle the equipment safely and carefully.
- Before use, inspect the equipment for misalignment or binding of moving parts, loose components, damage, or any other condition that may affect its operation. If damaged, have the equipment repaired by an authorised service centre or technician before use.
- Prevent unintentional starting of the equipment - ensure equipment and power switches are in the OFF position before connecting or moving equipment. Do not carry equipment with hands or fingers touching any controls. Remove any tools or other items that are not a part of the equipment from it before starting or switching on.
- Do not force the equipment. Use the correct equipment for your application. Equipment will perform better and be safer when used within its design and usage parameters.
- Use the equipment and accessories etc. in accordance with these instructions, considering working conditions and the work to be performed. Using the equipment for operations different from those intended could result in hazardous situations.
- Always keep equipment components (engines, hoses, handles, controls, frames, housings, guards etc) and accessories (cutting tools, nozzles, bits etc) properly maintained. Keep the equipment clean and, where applicable, properly lubricated.
- Store the equipment out of reach of children or untrained persons. To avoid burns or fire hazards, let the equipment cool completely before transporting or storing. Never place or store the equipment near flammable materials, combustible gases, or liquids etc.
- The equipment is not weather-proof, and should not be stored in direct sunlight, at high ambient temperatures or locations that are damp or humid.
- Do not clean equipment with solvents, flammable liquids, or harsh abrasives.
- For specific equipment safety use and care, see Equipment Safety.

General Electrical Safety

- Inspect electrical equipment, extension cords, power bars, and electrical fittings for damage or wear before each use. Repair or replace damaged equipment immediately.
- Ensure all power sources conform to equipment voltage requirements and are disconnected before connecting or disconnecting equipment.
- When wiring electrically powered equipment, follow all electrical and safety codes.
- Always use a Residual Current Device (RCD) (GFCI) / Earth Leakage Circuit Breaker / Safety Switch when operating this item (electrical items only).
- High voltage / high current power lines may be present. Use extreme caution to avoid contact or interference with power lines. Electrical shock can be fatal.

General Electrical Safety

- Electrically grounded equipment must have an approved cord and plug and be connected to a grounded electrical outlet.
- Do NOT bypass the ON/OFF switch and operate equipment by connecting and disconnecting the electrical cord.
- Do NOT use equipment that has exposed wiring, damaged switches, covers or guards.
- Do NOT use electrical equipment in wet conditions or in damp locations.
- Do NOT use electrical cords to lift, move or carry equipment.
- Do NOT coil or knot electrical cords, and ensure electrical cords are not trip hazards.

General Service Information

- The equipment must be serviced or repaired at authorised service centres by qualified personnel only.
- Replacement parts must be original equipment manufacturer (OEM) to ensure equipment safety is maintained.
- Do NOT attempt any maintenance or repair work not described in this manual.
- After use, the equipment and components may still be hot – allow the equipment to cool and disconnect spark plugs and/or electrical power sources and/or batteries from it before adjusting, changing accessories, or performing repair or maintenance.
- Do NOT adjust while the equipment is running.
- Perform service-related activities in suitable conditions, such as a workshop.
- Replace worn, damaged or missing warning/safety labels immediately.

Child Choking Hazard!

• WARNING: CHOKING HAZARD - CHILDREN UNDER 8 YRS. CAN CHOKE OR SUFFOCATE ON SMALL PARTS. ADULT SUPERVISION REQUIRED.

- Carefully inspect anything a baby or child could gain access to, including this product & packaging.
- Dangers include anything of a size that could become stuck or lodged in a baby or child's airway.
- Dangers include things like raw, hard fruit and vegetable pieces, large pieces of meat, bones or sausage skins, popcorn, nuts, hard lollies and corn chips, small magnets and batteries, coins, beads, marbles and small uninflated balloons, broken toys and smaller toys, buttons, keys, and coins. But there are also many more.
- Pay particular attention to accessories, nuts, bolts, screws, washers, caps, covers, loose parts, parts that could be removed or break off, pieces of packaging, staples, tape etc.
- In the case of any doubt, secure the item of concern in an appropriate manner, or completely remove the possibility of access by a baby or child.

Safe Handling Precautions

- **WARNING: WHEN THE MACHINE FIRST ARRIVES, LEAVE IT UNDISTURBED FOR 24 HOURS TO ALLOW THE LUBRICATING OIL IN THE COMPRESSOR TO SETTLE. THIS PRECAUTION PREVENTS POTENTIAL DAMAGE TO THE COMPRESSOR.**
- Do not use this Slush Machine outdoors. Exposure to rain may cause electrical leakage or electric shock.
- Never place this Slush Machine in a wet location or where it is vulnerable to water splashing. Damage to the insulation material may cause electrical leakage or electric shock.
- Never spray water directly on this Slush Machine. A wet Slush Machine may cause electric shock or short circuit.
- Do not put volatile or flammable substances into the Slush Machine bucket. Containers or areas with such substances may cause explosions or fires.
- Only qualified engineers or maintenance personnel should install this Slush Machine. Installing it yourself may cause gas or liquid leakage, electric shock, or fire.
- Never ground the Slush Machine through a gas pipe, water main, telephone line, or lightning rod. This is unsafe grounding.
- Never insert metal materials such as needles or wires into vents or air circulation openings. This may cause electric shock or personal injury due to accidental operation of moving parts.
- Place the Slush Machine firmly on solid ground. If the ground is unstable or the machine is not firmly placed, it may tip over and cause damage.
- Use the power supply specified on the nameplate of the Slush Machine. Using incorrect power sources can cause fire.
- Plug the power plug firmly into the socket after removing any dust. Dusty sockets or improper insertion may cause fire.
- Use a grounded socket to prevent electric shock. If there is no grounded socket, have a qualified engineer install a grounding device. Ensure the socket is easily accessible after installation.
- Do not use the machine in areas with high sulfuric acid, such as hot springs, or in salty environments like bays. This can cause internal corrosion and machine failure.
- When discarding the device, it must be disposed of and recycled by qualified personnel and institutions due to the presence of flammable materials.
- Do not stand on the machine, hang from it, or place heavy objects on it. This can damage the machine and cause injury.
- Do not damage the cooling circuit.
- Use the new hose assembly provided with the appliance. Do not reuse old hose assemblies.
- If any malfunction occurs, unplug the power plug immediately. Continuing to operate the machine abnormally may cause electric shock or fire.
- When dealing with toxic, harmful, or radioactive materials, use the Slush Machine in a safe location. Incorrect use can adversely affect health and the environment.

- Do not damage the power cord by processing, bundling, stretching, bending, or twisting it. This can cause electric shock or fire.
- Ensure there is no obstruction around the appliance or in the embedded structure to keep ventilation open.
- Before cleaning, maintaining, or inspecting the Slush Machine, unplug the power supply to prevent electric shock or personal injury.
- If some models use combustible refrigerants and flammable foaming agents, be aware of fire hazards (indicated by a "Fire Hazard" sign on the product). Repairs must be conducted by qualified personnel.
- This machine is not intended for use by individuals with physical weakness, slow response, or mental disorders (including children) unless supervised or assisted by a guardian. Children should be supervised to ensure they do not play with the machine.

Electrical Safety Precautions

- Please refer to the nameplate for the voltage range of the Slush Machine. If the voltage is not within this range, please purchase a voltage regulator of more than 2000W.
- Ensure the ground wire is properly connected. The safe ground wire should not be connected to the water pipe or gas pipe.
- To protect the compressor, do not start the Slush Machine again within ten minutes after a power outage.
- Do not connect other electrical appliances to the same socket.
- If the power cord is damaged, it must be replaced by personnel arranged by the manufacturer or professionals with relevant qualifications to avoid danger.
- The electric control system has a voltage of more than 36V. Do not open or touch it during use. For maintenance, contact the manufacturer or relevant qualified technical personnel.
- **WARNING: DO NOT OPERATE THE SLUSH MACHINE IF THERE IS A GAS LEAK IN THE ENVIRONMENT WHERE THE SLUSH MACHINE IS LOCATED. SPARKS CAUSED BY UNPLUGGING OR START-STOP CONTROL MAY CAUSE A FIRE. FIRST, CUT OFF THE POWER, OPEN THE WINDOWS, AND LET THE AIR CIRCULATE.**

Installation Precautions

Requirements for Handling and Moving Conditions:

- When handling, try to keep the box upright. The maximum inclination should not be more than 45°. Do not invert or place horizontally.
- To operate the Slush Machine correctly and achieve the best performance, please place the Slush Machine in an area that meets the following conditions:
 - Solid and flat ground: Ensure the ground is stable and level.
 - Stay away from heat sources: Avoid placing the Slush Machine near heating equipment, such as gas flames or stoves. Excessive heat can decrease the cooling efficiency of the Slush Machine.
 - Avoid direct sunlight: If the Slush Machine is exposed to direct sunlight, it may cause abnormal operation and shorten the machine's lifespan.
 - Dry area: Avoid placing the Slush Machine in wet areas, such as near faucets or sinks.
 - **CAUTION! INSTALL A DISCONNECT SWITCH**
 - If the Slush Machine is placed in a wet area, a circuit breaker must be installed, and the machine must be grounded. Install the circuit breaker in the power line. For further information, please consult the Slush Machine retailer or an electrical technician.
 - **WARNING! Be sure to use a plug with a ground wire structure and ground the Slush Machine to prevent electric shock during leakage.**
 - Replacing grounding terminals with water pipes will not provide proper grounding protection in many cases because plastic pipes are often used in plumbing.
 - Never ground the Slush Machine through a gas pipe, as this is very dangerous.
 - Never ground the Slush Machine through telephone lines or lightning protection, as thunder and lightning can generate a large current, making this grounding very dangerous.
 - Ensure nothing can fall into the area where the Slush Machine is stored.

Environmental Conditions

This equipment is designed in accordance with the following conditions:

- Use it indoors.
- The elevation should be no more than 2000 meters.
- The ambient temperature should be in the range of 10°C-32°C.
- When the temperature is not higher than 31°C, the maximum relative humidity is 80%. The maximum relative humidity decreases linearly with the increase of temperature.
- The voltage fluctuation of the main power supply should not exceed $\pm 10\%$ of the rated voltage.
- Comply with the equipment installation level (overvoltage level) transient overvoltage.

This apparatus is used for similar purposes, such as:

- The kitchen area of a store, office, or other workplace.
- Customers of farms, hotels, motels, and residential environments.
- Family hotel environments.
- Catering and similar non-retail applications.

This appliance is not intended for general household use.





















Correct Operation

When using the Slush Machine for the first time and running it continuously, please follow these rules:

- The Slush Machine should be connected to a special socket (the power supply should be the same as specified by the manufacturer).
- Ensure the Slush Machine's refrigeration system has an unobstructed cooling channel. Do not place any items that may block it.
- After completing the inspection of the Slush Machine, turn on the power supply and power on the machine.
- Ensure there is enough space around the Slush Machine for proper ventilation.
 - Do not store any items in the bucket.
 - Keep the Slush Machine away from heat sources and avoid using it in high or low-temperature environments. Avoid direct sunlight to prevent heat dissipation issues.
 - Do not pour water directly onto the surface of the Slush Machine, as this may cause short circuits, electrical leakage, and other failures.
 - If the Slush Machine will not be used for an extended period, power it on and run it for 4 to 6 hours each month.
 - Ensure there is at least 30cm of space around the Slush Machine to facilitate proper heat dissipation.

Safety Symbols

The product may have safety warning labels attached to it, explained below. Understand the symbols on your product and their meanings. If any stickers become unreadable, unattached etc., replace them.

 <p>Flammable Material Hazard Flammable liquids, gases, or substances etc may present. Avoid ignition sources and open flames. Danger of fire.</p>	 <p>Read User Manual Read and fully understand product safety warnings, operation, procedures etc before using the product.</p>	 <p>Use Hand Protection Wear appropriate hand protection and take due care as the product or use of the product may present hand hazards.</p>	 <p>Carbon-Monoxide Hazard Do not use the product in confined areas or without adequate ventilation. Carbon-monoxide poisoning can be fatal.</p>
 <p>Electrocution / Electrical Shock Hazard High voltage or high current electricity may be present or required by the product. Take due care when handling electrical products, cables, plugs and leads. Electrical shock can be fatal.</p>	 <p>Toxic Fumes / Dust Hazard Using the product or by-products from use may produce fumes, smoke or particles that could be harmful if inhaled. Wear appropriate breathing protection and have adequate ventilation.</p>	 <p>Explosive Material Hazard Combustible liquids, gases, or substances etc may be present. Avoid ignition sources and open flames. Danger of explosion.</p>	 <p>Cutting / Amputation Hazard The product may have blades, edges or mechanical devices that can cause severe cut injury to fingers, limbs etc. Take due care when handling and using the product.</p>
 <p>Crush Hazard The product may have blades, edges or mechanical devices that can cause severe crush injury to fingers, limbs etc. Take due care when handling and using the product.</p>	 <p>Single Operator Only The product must be operated by a single person only. More than one person operating the product may introduce additional hazards.</p>	 <p>Use Face Protection Wear appropriate full-face protection and take due care as the product or use of the product may present face and eye hazards.</p>	 <p>Use Foot Protection Wear appropriate foot protection and take due care as the product or use of the product may present foot hazards.</p>
 <p>Use Eye / Ear / Head Protection Wear appropriate eye and / or ear and / or head protection and take due care as the product or use of the product may present eye, hearing, and head hazards.</p>	 <p>Running Hazard Do not run on or near the product as doing so may present a fall hazard.</p>	 <p>Diving Hazard Do not dive into the product as doing so may present a neck / head injury hazard.</p>	 <p>Adult Supervision Required Always supervise children and other users of a product to prevent drowning or injury.</p>
 <p>Skin Penetration / Puncture Hazard The product may produce pressure, emit liquids or objects that can cause severe injury to fingers, limbs, blood etc. Take due care when handling and using the product.</p>	 <p>Hot Surface Hazard Be aware that the product may produce high temperatures and hot surfaces that can cause burn injuries.</p>	 <p>Flying Debris Hazard Be aware that the product or use of the product may present hazards produced by flying debris. Wear appropriate clothing and protective devices.</p>	 <p>Moving Parts Hazard Be aware that the product contains or uses mechanical devices that move or rotate. Always wait for moving parts to stop fully before handling the product, adjusting, maintenance etc.</p>

 <p>Carbon-Monoxide Hazard Do not use the product in confined areas or without adequate ventilation. Carbon-monoxide poisoning can be fatal.</p>	 <p>Pull Hazard Be aware that the product contains or uses mechanical devices that can pull in objects and can cause severe injury to fingers, limbs etc. Take due care when handling and using the product.</p>	 <p>Slope / Fall Injury Hazard Be aware that using the product on sloping surfaces or in slippery conditions may present additional dangers from falls and contact with blades, moving parts, hot surfaces etc.</p>	 <p>"Slam Dunk" Warning Do NOT attempt "slam dunk" manoeuvres as this may result in severe injury due to falling, product breakage or collapse etc.</p>
 <p>Electrocution / Electrical Shock Hazard - Outdoor High voltage or high current electricity may be present or required by the product. Do NOT use in rain, damp, or wet conditions. Electrical shock can be fatal.</p>	 <p>Electrocution / Electrical Shock Hazard - Disconnect High voltage or high current electricity may be present or required by the product. Always disconnect the product from the electrical supply before handling the product, adjusting, maintenance etc.</p>	 <p>Power Line Electrocution Hazard High voltage / high current power lines may be present. Use extreme caution to avoid contact or interference with power lines. Electrical shock can be fatal.</p>	 <p>"Kick-Back" Hazard High level of "kick-back" hazard that can cause the machine to suddenly rotate towards operator. Kick-back injury can be fatal.</p>
 <p>Winch Operator Position Hazard Do NOT stand between winch and load. Do NOT use winch to move people.</p>	 <p>Winch Lift Hazard Do NOT LIFT load vertically. Use machine to PULL only.</p>	 <p>Cable Hazard Ensure that load bearing cable is not kinked or knotted.</p>	 <p>Winch Cable Hazard Ensure that there is a minimum number of cable coils on winching mechanism.</p>
 <p>Winch Hook Hazard Carry hook to load – do NOT throw or run.</p>	 <p>Flash / Blinding Hazard Wear appropriate eye protection for welding. Direct exposure to weld arcs may cause permanent eye injury.</p>	 <p>Laser Hazard Laser may be in use – do NOT look directly at laser or allow others to.</p>	 <p>Choking Hazard Children under 8 yrs. Can choke or suffocate on small parts. Adult supervision required.</p>

Table of Contents

Safety	2
Safety Symbols	6
Parts Identification	9
Assembly	10
Beater Assembly	10
Hopper Assembly	11
Outlet Assembly	11
Hopper Lid Assembly	12
Operation	13
Control Panel Features	13
Control Panel Description	14
Slush Preparation	15
Cleaning and Maintenance	19
Preparation Before Cleaning	19
Cleaning and Safety Guidelines	19
Cleaning Steps	20
Cleaning the Condenser	25
Troubleshooting	26
Specifications	27

Parts Identification

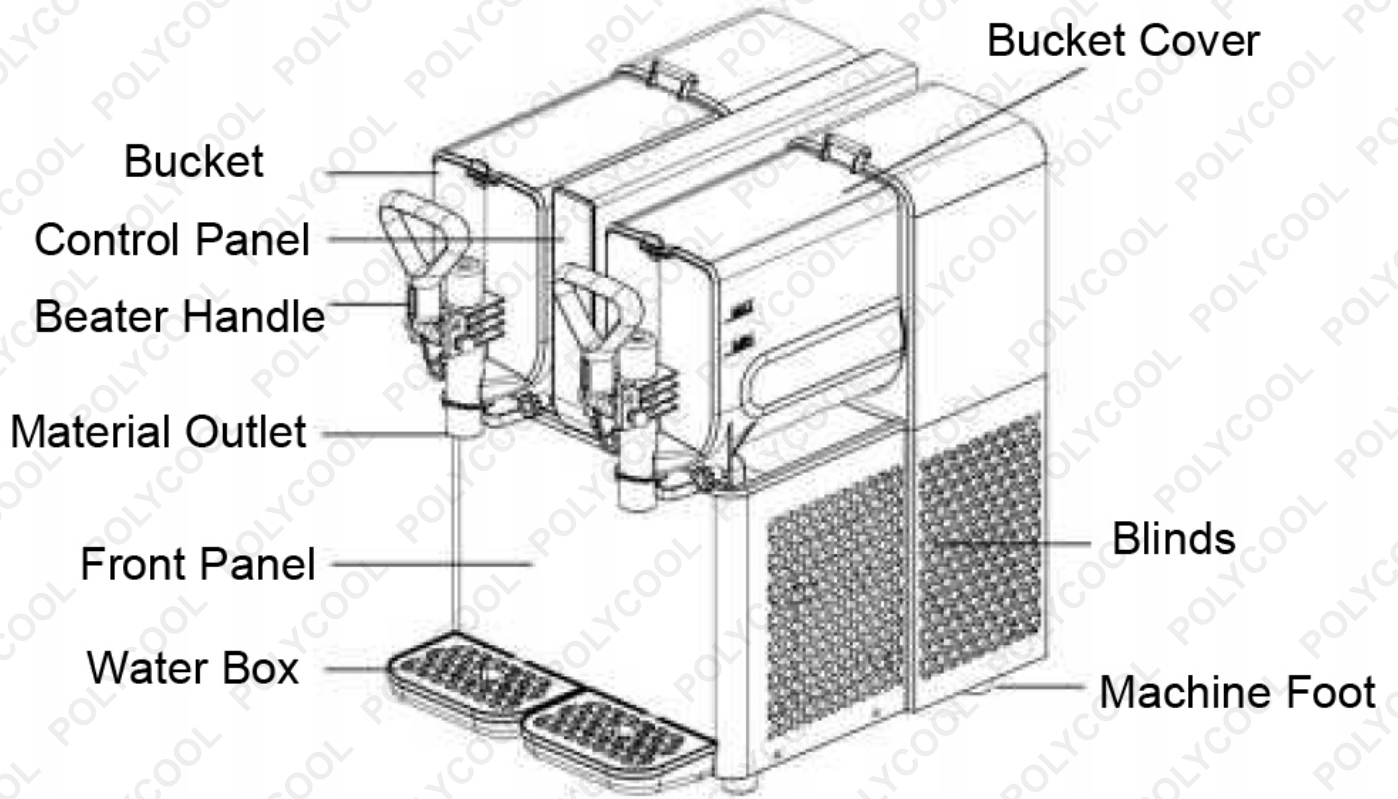

Assembly

All parts that have been cleaned and sanitized must be properly reassembled. Some parts must be lubricated so that they can be used for a longer period of time.

Assembly of sealant seals

Place the sealant seal in the front groove of the beater groove of the beater.

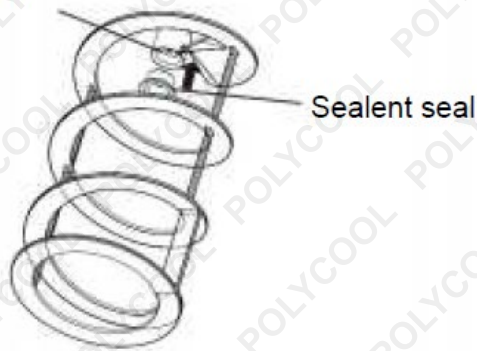

Apply vaseline to the sealant seal.

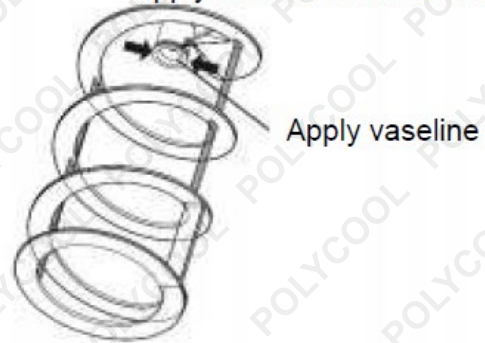

Beater Assembly

Apply Vaseline to the outer surface of the rear sealing ring of the evaporator. Insert the rear sealing ring into the base of the evaporator. Install the assembled beater into the evaporator, inserting the limit end of the beater into the drive shaft. Gently push the beater forward and rotate it until the limit head of the beater snaps into the limit of the drive shaft. At this point, the bell mouth seal should touch the evaporator. Finally, tighten the fastening screw of the beater clockwise.

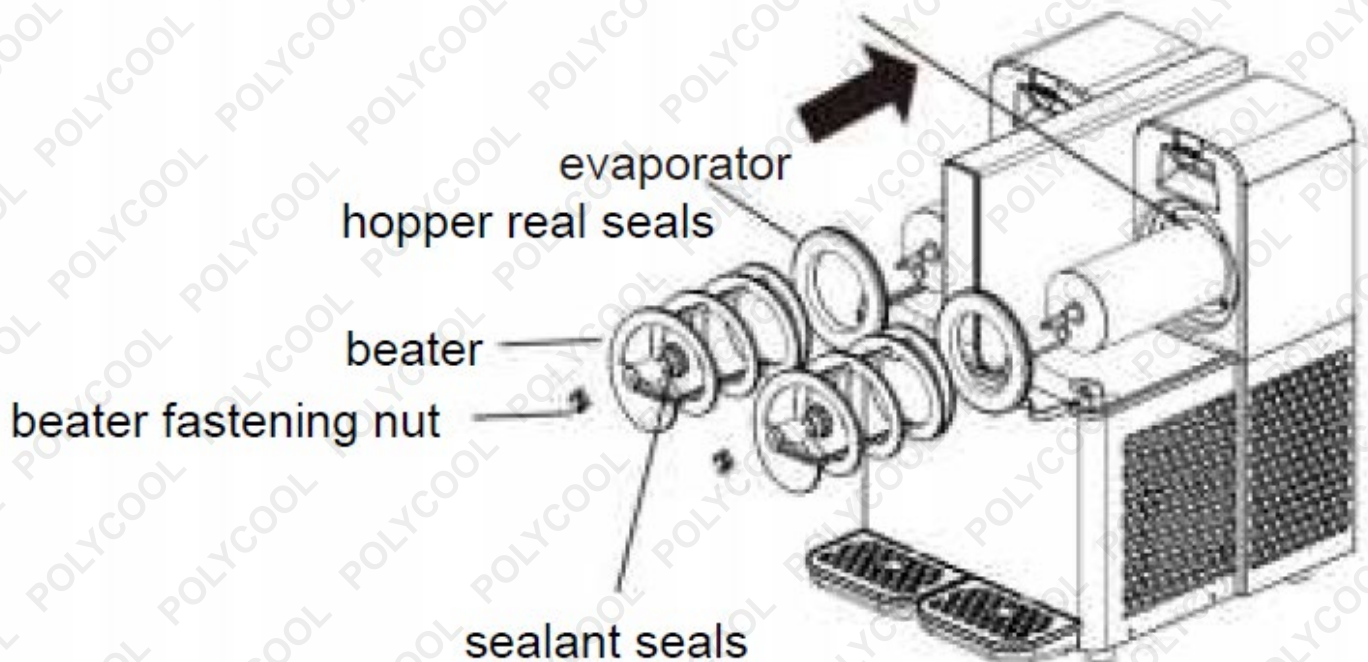

Hopper Assembly

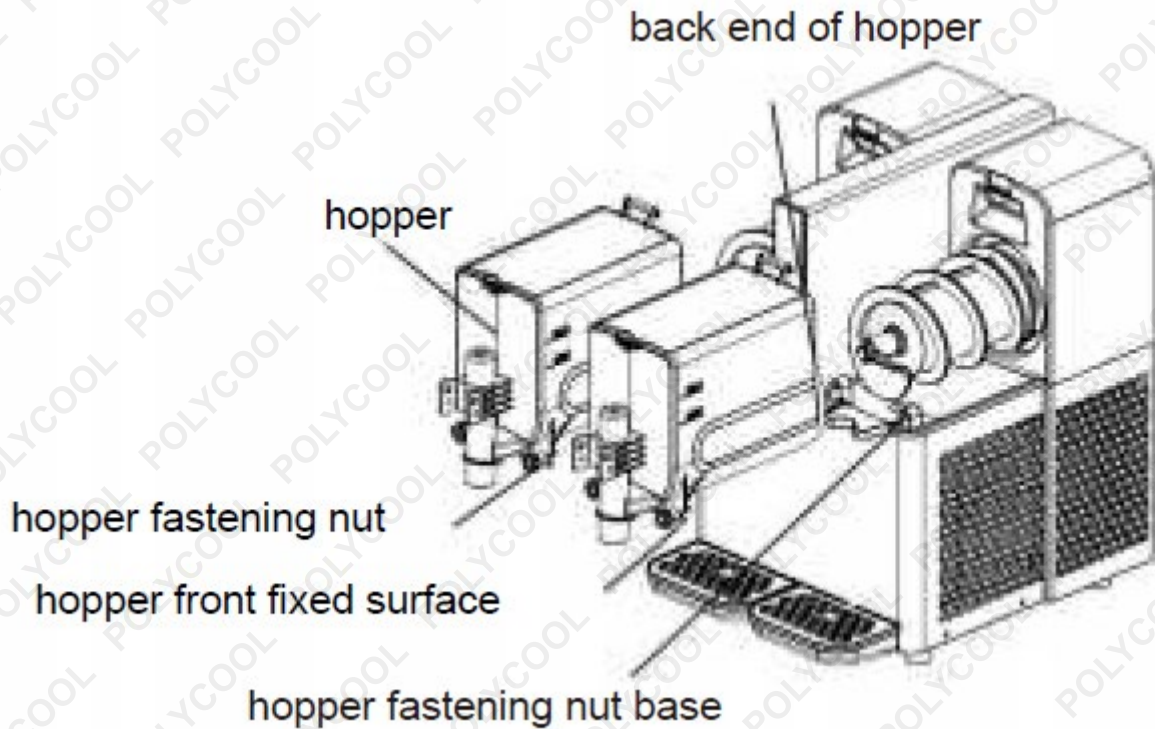

Insert the hopper into the evaporator, positioning the rear end of the hopper into the rear sealing ring of the evaporator. Push the hopper forward firmly until the front fixing surface of the hopper fits with the fixing seat of the fastening nut. Finally, lock the hopper in place with the fastening nut.

Outlet Assembly

1. Place the discharge spring in the designated position above the valve stem, and then insert it from the bottom of the discharge port of the barrel.
2. Insert the protruding part of the front end of the handle into the corresponding groove of the valve stem. Rotate the handle until the rotation hole of the handle aligns with the rotation hole of the barrel handle.
3. Insert the handle pin into the aligned rotation holes of the barrel handle and the handle. Secure the handle pin with the handle pin nut and the handle horizontal pin.

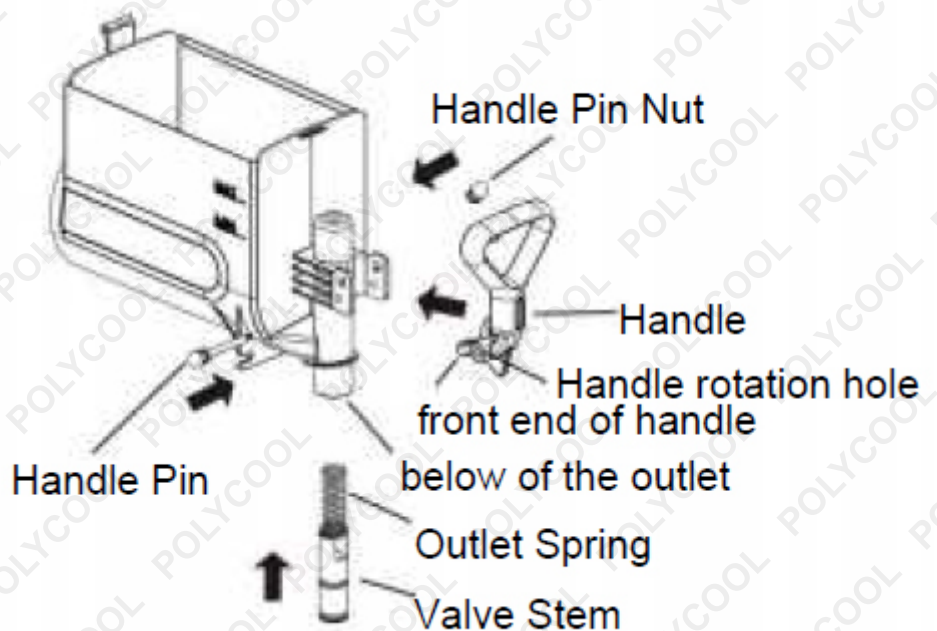

Note: The valve stem sealing ring should be coated with Vaseline before assembling it with the discharge port.

Hopper Lid Assembly

Align the rotating hole on the back of the hopper lid with the fixing hole of the hopper lid on the back of the barrel. Insert the fixing horizontal pin of the hopper lid into the rotating hole, ensuring that the front limit protrusion of the horizontal pin extends outwards.

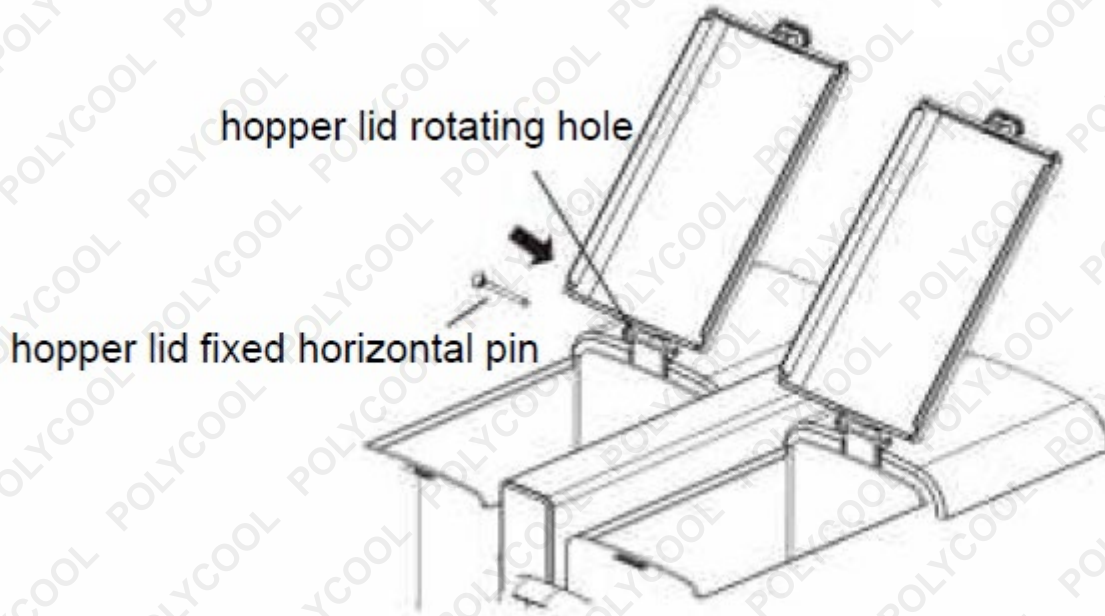

Operation

Control Panel Features

Double Hopper Display

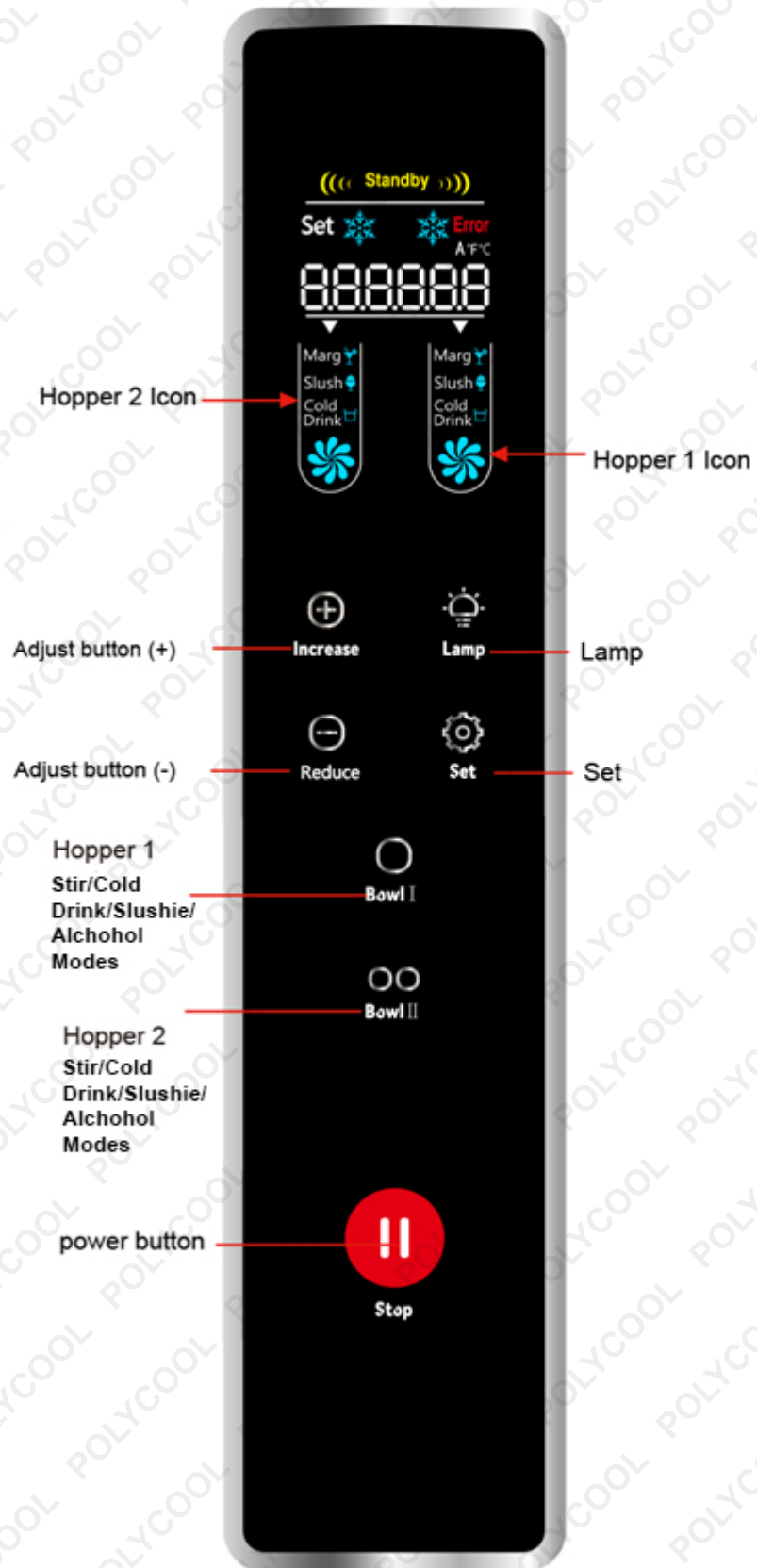
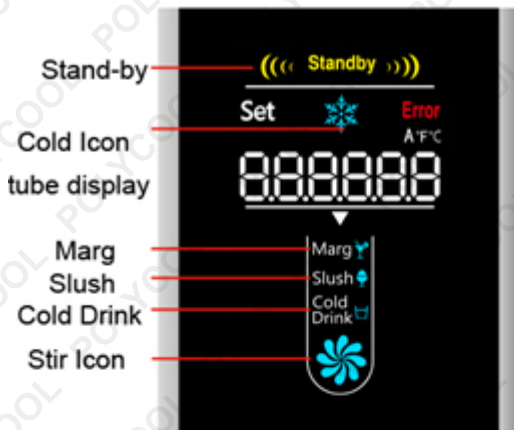

Control Panel Description

Power On:

1. Press the power switch to turn on the machine.
2. The LCD screen displays "Standby", and all touch button lights are illuminated.

Single Hopper Operation:

1. When a single hopper's stir function or cold function is turned on, the display shows the current temperature in the hopper as "888888".
2. The digital tube displays .
3. The number "1" on the left indicates hopper 1, and the current temperature in the hopper is displayed on the right.
4. The left side does not display on the single tank / hopper model.
5. When more than one hopper is in operation, the temperature for each tank will scroll across each tank for 8 seconds each.
6. The arrows underneath the temp gauge will also light up, indicating which tanks temperature is being displayed.

Control Panel:

1. Press the Hopper 1 button to start the stir function for Hopper 1. The stir icon will begin spinning indicating that the motor is in operation
2. Press the Hopper 1 button again to turn on the cold drink function for Hopper 1. The refrigeration system will start, and the snowflake icon will begin flashing. The cold drink icon will also flash.
3. Press the Hopper 1 button again to activate the slushie mode. The slushie icon will flash.
4. Press the Hopper 1 button once more to start the alcoholic drinks function for Hopper 1. The margarita icon will flash.
5. Press the Hopper 1 button again to put Hopper 1 into standby mode. This will turn off the cooling function and the motor will stop spinning.
6. The same steps above apply for Hopper 2 depending on which tank you wish to use

NOTE: If the stirring motor for the other hoppers is not turned on, the cold function will also be turned off simultaneously. It will not cool the tank if the motor is not turned on.

Lamp Button:

Short press the lamp button to turn on the LED light in the tank. Press the lamp button again to turn off the LED light.

Note: The default values have been set at the factory for sufficient slushy consistency. Only adjust if absolutely necessary

Set Button:

Press and hold the setting button for 5 seconds to enter the user parameter setting state. The left 2-digit digital display will show the parameter code, and the right 3-digit digital display will show the parameter value. At this point, press the setting button to switch parameters, and press the adjust button (+) or adjust button (-) to change the parameter value. After the settings are completed, wait for 5 seconds to exit the parameter setting interface, and the parameters will be saved automatically. The user parameter code table is as follows: (See next page....)

Double Hopper parameter table

Display code	parameter name	Defaults	Setting range
S1	Hopper (1) slush temperature set point	-2°C	0°C to -10°C
S2	Hopper (2) slush temperature set point	-2°C	0°C to -10°C
C1	Hopper (1) drink temperature set point	5°C	0°C to 10°C
C2	Hopper (2) drink temperature set point	5°C	0°C to 10°C
F1	Hopper (1) marg temperature set point	-5°C	0°C to -10°C
F2	Hopper (2) marg temperature set point	-5°C	0°C to -10°C

Slush Preparation

1. Preparation of the Mixture

In a suitable container, dilute the concentrate with water and stir according to the manufacturer's instructions. The sugar content of the mixture should be kept between 1.3% and 1.8%. Lower and higher concentrations can damage the stirrer and stirrer motor.

NOTE: The liquid will not freeze if the mixture is not correct. If you put water only in the tank, it will not freeze.

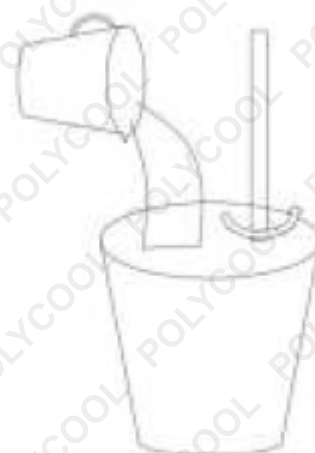

2. Open the lid

Cover front button

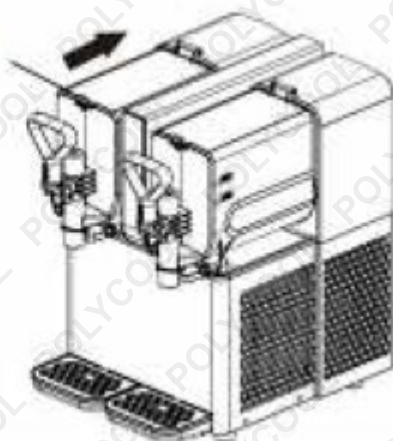

Press the front button of the cover in the direction of the arrow to separate the button of the cover from the button of the barrel, and then lift the cover.

WARNING: Do not force the lid open.

3. Pour in the mixture

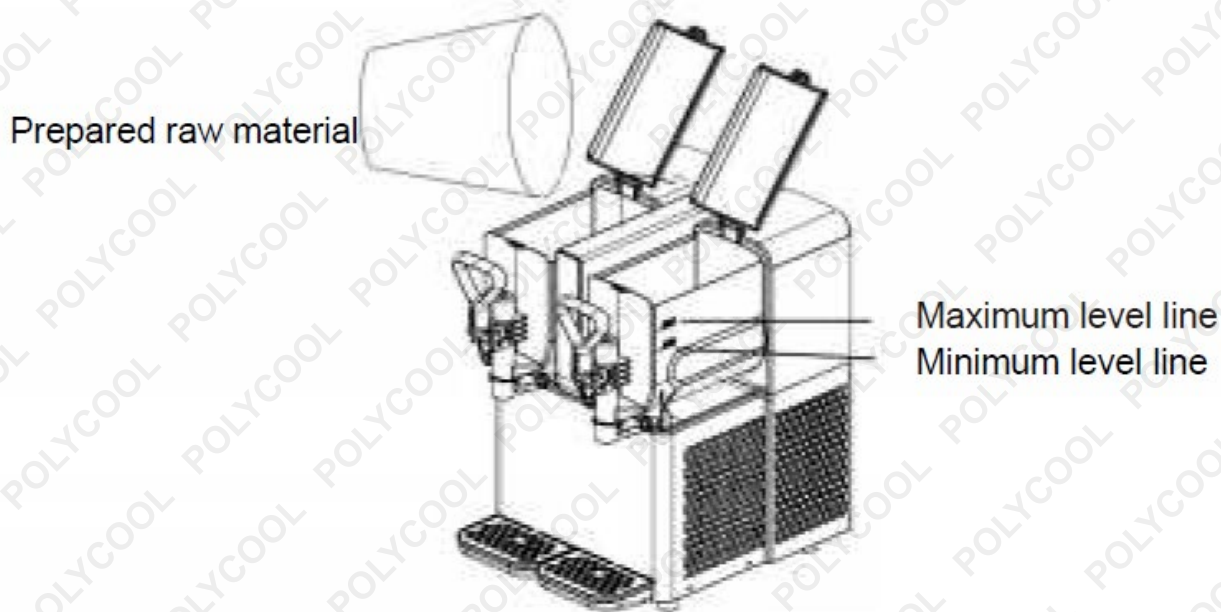

Mix the ingredients well and pour them into the hopper.

Note: Do not fill with hot liquids (temperature over 25 degrees Celsius). The poured raw materials must not exceed the maximum liquid level line (about 2.5L), nor be lower than the minimum liquid level (about 1.5L).

4. Close the lid

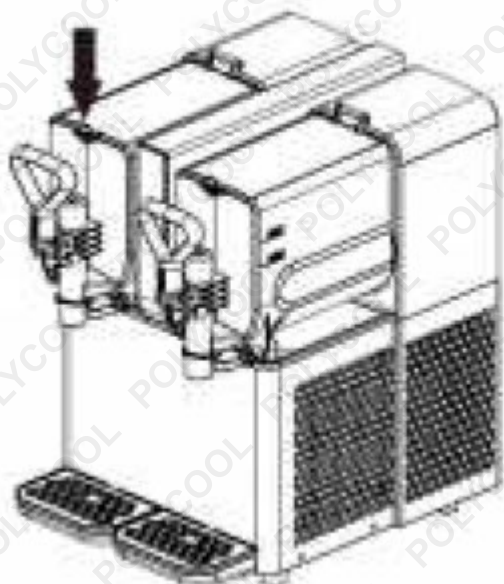

After the raw materials are poured, close the lid, and then press the lid buckle in the direction of the arrow, so that the lid buckle and the bucket buckle can be securely closed.

WARNING: Pour ingredients into the bucket only when the machine is OFF or not plugged in.

5. Start the machine

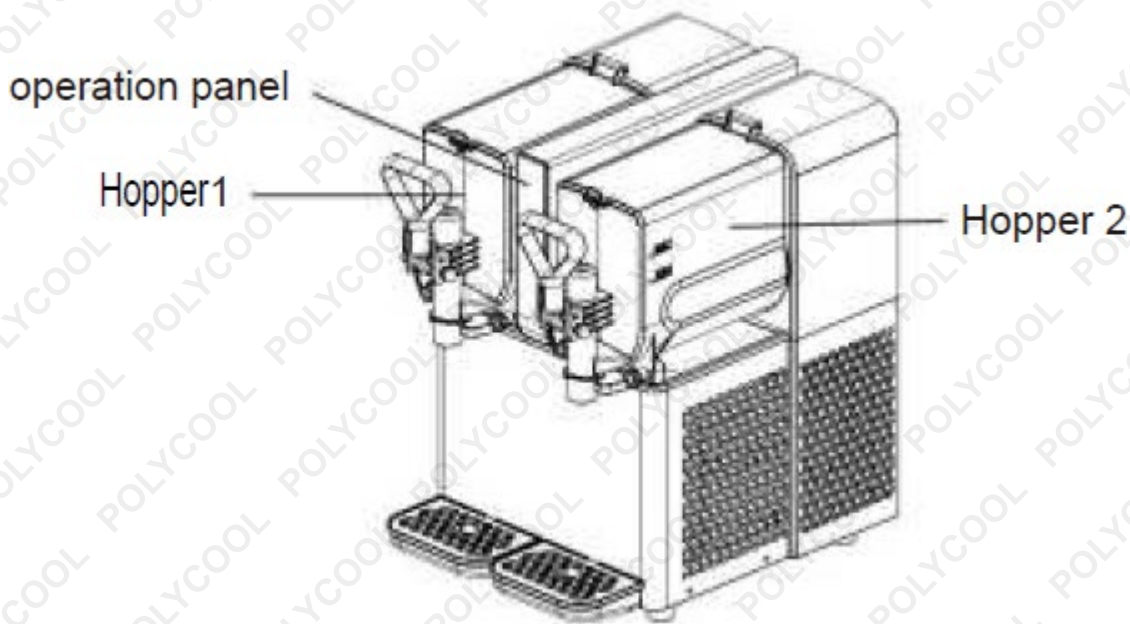

WARNING: DO NOT insert fingers into the machine while in operation.

6. Produce slush

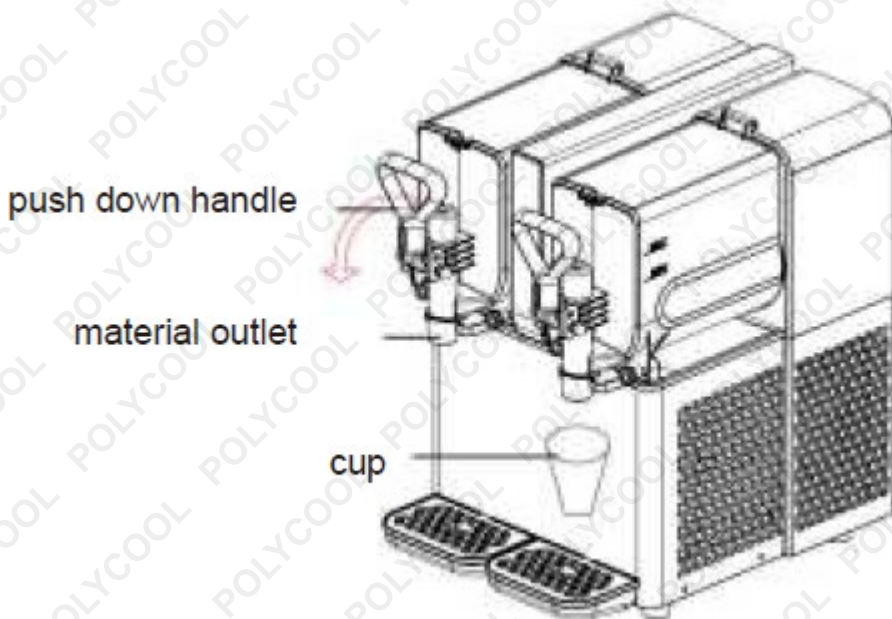

Place a container under the discharge port, then press down on the handle. The mixture made in the hopper will flow out automatically.

7. Simple cleaning of the hopper

- Empty the hopper.
- Turn OFF the power.
- Prepare hot water not exceeding 50°C, then open the lid of the hopper and pour the hot water into the hopper.

- d. Turn ON the power of the machine, then press the stirring switch of the corresponding hopper and let the stirrer run for 0.5 - 1 minute.
- e. Release all the hot water in the hopper, then repeat the operation 2 - 4 times.
- f. Turn OFF the power of the machine.

Attention: Please pour clean hot water into the corresponding hopper that needs to be cleaned, and do not exceed the maximum water level indicated on the hopper. If you want to thoroughly clean the machine, please turn off the machine before proceeding. The operation should not exceed 2 minutes.

8. Slushy Softness Adjustment

Press the setting button to enter the parameter setting mode. If you want the slush to be harder, lower the slush temperature setting value. Conversely, increase the temperature setting value to make the slush softer.

Note: The hardness of the slush has been adjusted before leaving the factory. We do not recommend adjusting the consistency unless absolutely necessary.

Cleaning and Maintenance

Before cleaning or maintaining the external parts of the machine, please confirm that the power switch is off, and the power plug is pulled out. Before any cleaning or maintenance, be sure to wear protective equipment (rubber gloves, protective glasses, etc.) to ensure your safety.

Preparation Before Cleaning

- Cleaning Utensils (bucket, soft brush, soft rag)
- Clean water and hot water (not exceeding 50°C)
- Food-grade neutral detergent
- Food-grade sanitizer
- Food-grade lubricant (such as Vaseline)

Cleaning and Safety Guidelines

- Wear protective gloves.
- Do not use strong acids, alkalis, or flammable substances.
- Do not use rough surfaces or metal sponges to clean the machine and other parts.
- Do not spill the cleaning liquid on the surrounding area.
- Do not dry parts on the stove or in the microwave.
- Do not wash parts in drums.
- Do not immerse the machine in water.
- Clean with a disinfectant that meets food hygiene requirements.

When cleaning is complete, verify that any protective covers or safety devices that were removed or opened are back in place and secure.

IMPORTANT! Cleanliness and sanitation are crucial and must be taken seriously. These practices are enforced based on hygienic health standards to ensure the quality of beverages.

NOTE: The hopper must be cleaned at least once a day. It must comply with the health standards implemented in the country where it is located, and the frequency of cleaning may need to be increased based on actual conditions. For more information, please consult the product supplier. If the machine is not used continuously throughout the day, please use a clean, soft cloth to wipe the outlet area (the box area in the figure below).

Outlet area

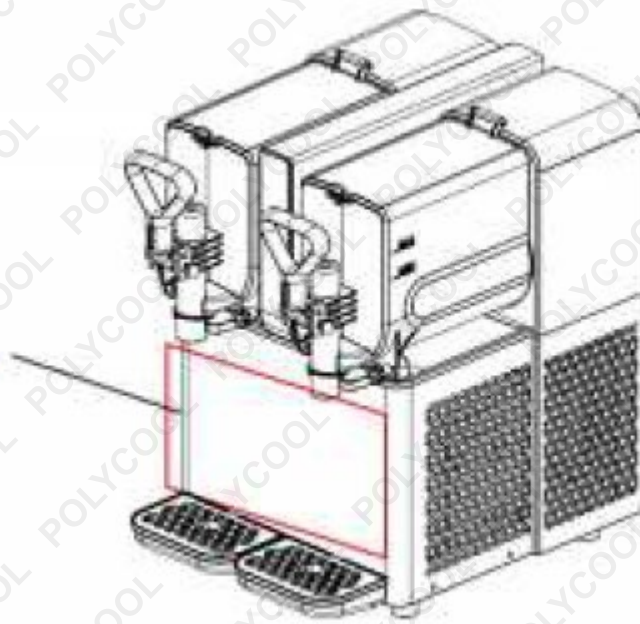

When the plug is not pulled out or the power switch of the machine is not turned off, it is strictly forbidden to clean or maintain the machine. Be careful when cleaning, as insufficient cleaning will cause a large number of bacteria to multiply.

Cleaning Steps

1. Empty the material in the hopper.

- Only turn ON the mixing function of the machine.
- Place a container under the discharge port.
- Press down the handle to discharge the material in the hopper.
- After draining the raw materials from the hopper, turn off the power of the machine.
- Unplug the power plug of the machine.

Raw material in hopper

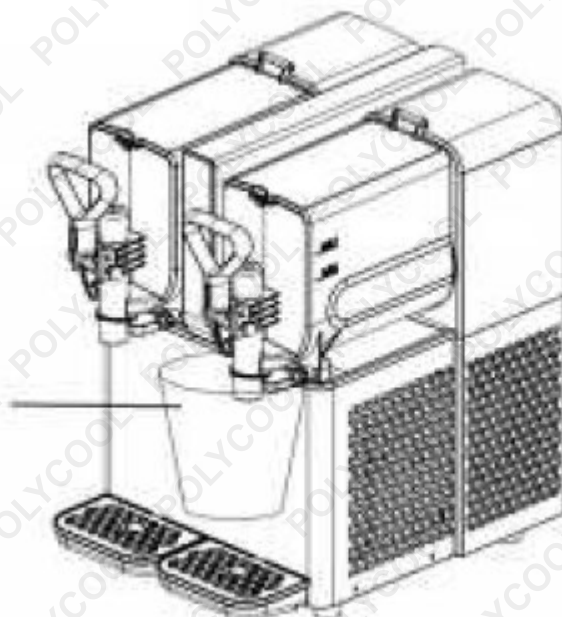

2. Remove spout assembly

- a. Loosen the handle pin nut on the handle pin by turning it counterclockwise.
- b. Remove the handle pin.
- c. Take out the handle.
- d. Remove the discharge spring.
- e. Finally, remove the valve stem.

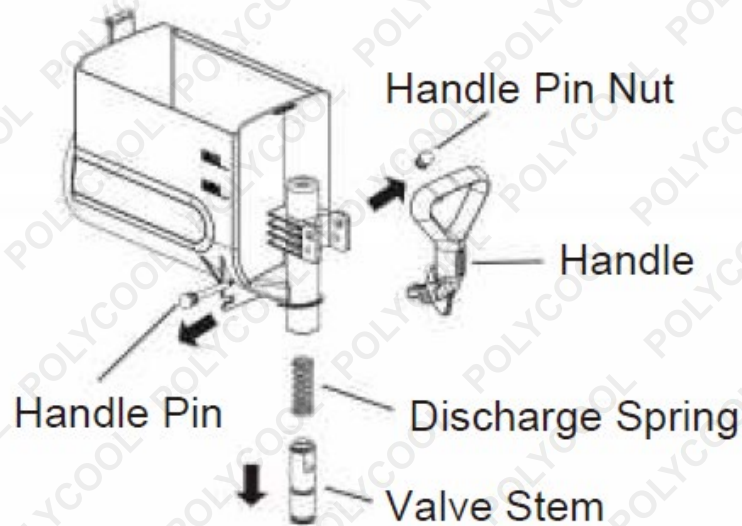

Put the disassembled outlet assembly into clean water for cleaning.



NOTE: If there are raw materials or liquid remaining in the hopper, please do not disassemble the outlet assembly.



Water box

WARNING: The water box is strictly prohibited from bearing any weight.

3. Removing the hopper assembly

Disassembling the hopper is the most basic operation to ensure the machine is thoroughly cleaned. Please follow the steps below to dismantle the hopper:

- a. Turn the barrel tightening nut counterclockwise to remove the nut from the machine.
- b. The drum can be removed by gently pushing it forward from the rear end of the drum.



Hopper fastening nut

4. Removing the Material Hopper Lid:

- a. Lift the cover of the material hopper.
- b. Pull out the rotation positioning pin of the material hopper lid in the direction of the arrow to remove the material hopper lid.

Hopper lid rotation positioning pin

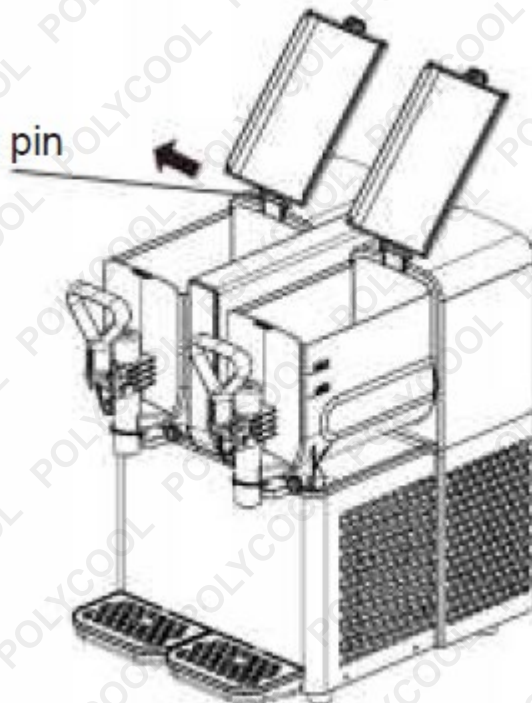

5. Remove the Beater Assembly:

- a. Twist off the fastening nut at the front end of the beater counterclockwise.
- b. Remove the fastening nut, beater, sealant seals, and rear sealing ring from the material barrel.

Hopper rear seal
beater
beater fastening nut
sealant seals

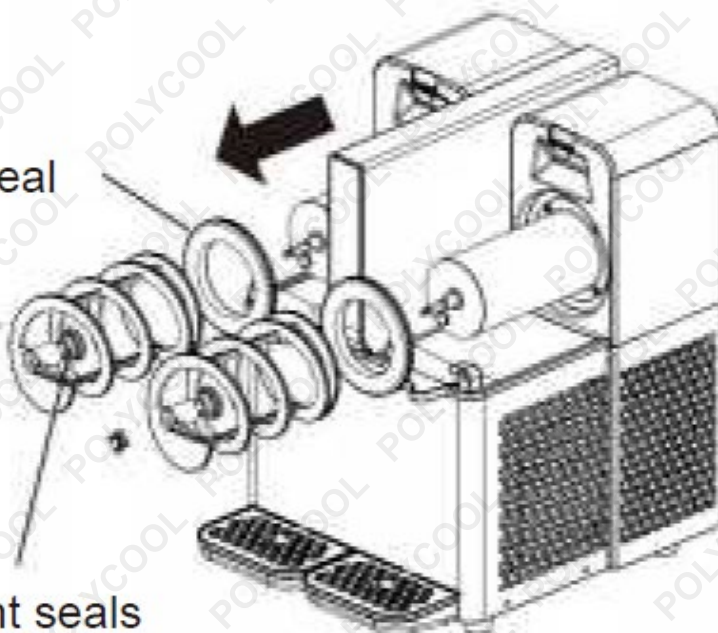

6. Removing the water box

First, pull out the residual material pipe from the water receiving box. Then, lift the water receiving box vertically to remove it.

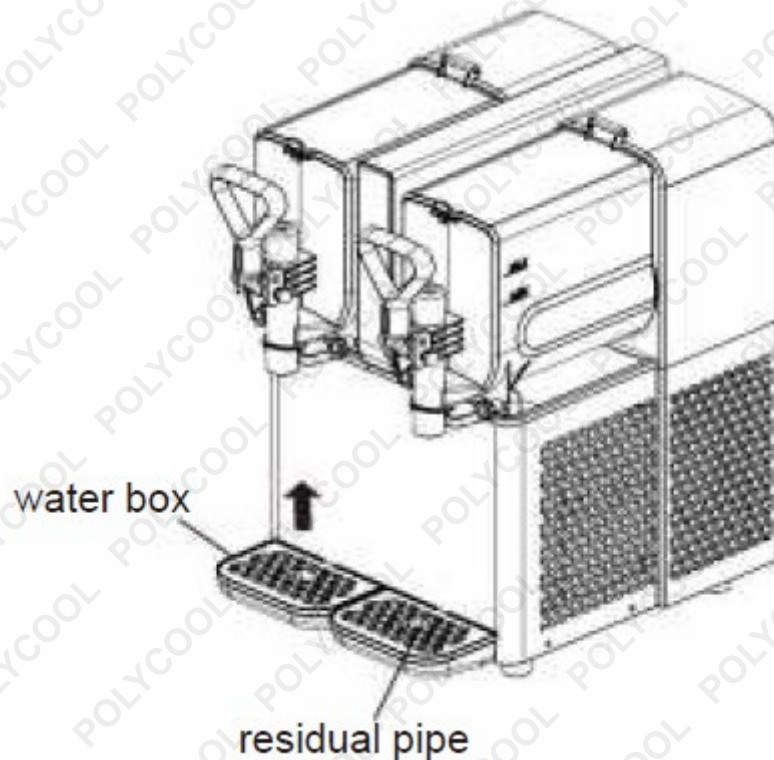

When disassembling the water receiving box, do not drag the residual material pipe carelessly to avoid damaging it. The water receiving box should be emptied and cleaned daily.

7. Cleaning accessories

All dismantled parts should be thoroughly cleaned.

Note: The cleaning method must comply with the current hygiene and health standards of the country where the machine is used.

Please clean the parts as follows:

- Pour an appropriate amount of neutral cleaning agent into a suitably sized container, then add the corresponding proportion of water to dilute the cleaning agent.
- Clean the surface of the disassembled parts with a soft cloth covered with the diluted cleaning agent, then rinse the parts thoroughly with clean water.
- Pour an appropriate amount of food-grade disinfectant into another suitably sized container, then add the corresponding proportion of water to dilute the disinfectant.
- Put the parts that have been thoroughly rinsed with the cleaning agent into the diluted disinfectant and soak for about 30 minutes. Then, take them out and wash them thoroughly with clean water.
- Place the cleaned parts in a clean place to dry naturally.

8. Cleaning the Evaporator

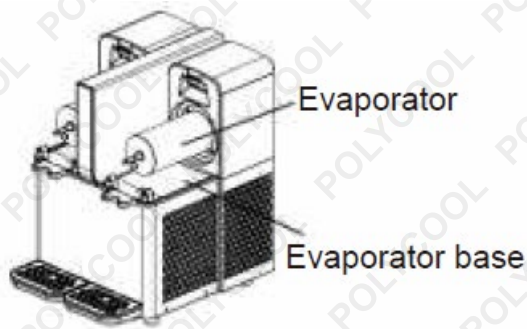

Wipe the surface of the evaporator and its base with a soft cloth soaked in diluted cleaning agent. Then, wipe the surface of the evaporator with a clean, wet cloth. Repeat the process on the base of the appliance 2-3 times.

Next, wipe the surface of the evaporator and its base several times with a soft cloth coated with diluted disinfectant, and leave the disinfectant on the wiped surface. After half an hour, thoroughly wipe the surface of the evaporator and its base with a clean, wet cloth.

9. Clean the Hopper Lid



Wipe the outer surface of the hopper lid with a clean, wet rag. Then, wipe the bottom surface of the hopper lid several times with a soft rag coated with diluted disinfectant, leaving the disinfectant on the wiped surface. After half an hour, thoroughly wipe the bottom surface of the hopper lid with a clean, wet rag, then dry the bottom surface with a clean, dry rag.

10. Clean the machine body

Dip a clean, soft cloth in the diluted cleaning agent and wipe the machine body again. Then, wipe the machine body clean with a soft, damp cloth dipped in clean water. Finally, dry the body with a clean, dry cloth.

Cleaning the Condenser

After operating for some time, the condenser may accumulate dust, which can affect heat dissipation and reduce cooling efficiency. This can be indicated by a decrease in the output of the slush machine or difficulty in forming slush within the usual timeframe. It is recommended to clean the condenser every three months, or once a month if the operating environment is poor. Always have a professional cleaner perform this task. Ensure the power is turned off before cleaning, and take care not to damage the condenser fins.

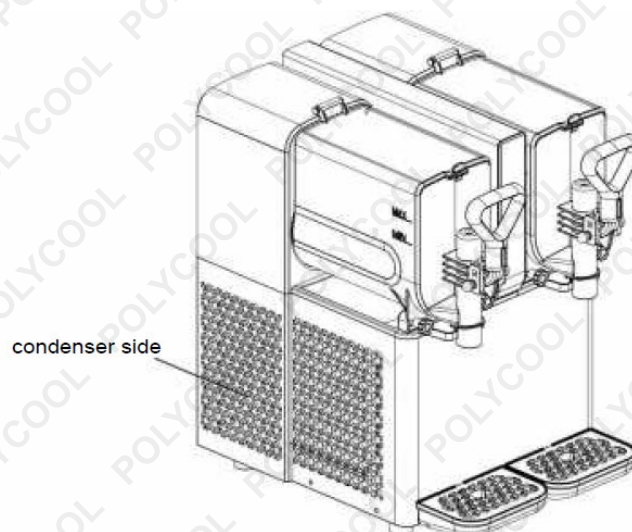

Troubleshooting

Faults	Cause Analysis	Possible Solutions
The machine can't be turned ON.	No power input	Insert the machine power plug into a suitable outlet
	Machine power switch is not turn on	Turn on the power switch
The material outlet is leaking.	Outlet parts are not lubricated	Apply lubricant to the outlet parts
	Stem seal damaged	Replace stem seal
Raw material is leaking from the back of the Hopper	Hopper not installed in proper position	Check the hopper install
	Hopper seal not lubricated	Apply lubricant
	Hopper seal get broken	Replace the seals
The beater can't work	Machine power switch is not turned on	Switch on the machine
	Icing on the surface of the evaporator	Turn off the machine, let the ice melt
The machine doesn't make slush	Machine power switch is not turned on	Turn on the machine
	The slush hardness is not adjusted to the appropriate level	Adjust slush hardness
	Condenser too dirty	Clean condenser
	The slush machine is close to the heat source, and the surrounding heat is not good	Place the machine in an appropriate place
There is noise on the beater	Sealants seals don't assembly well	Check if the seals is installed well
	Slush hardness is too hard	Re-adjust the hardness
	Sealant seal not lubricated or damaged	Apply lubricant or re-place with new one
	Raw material sugar content is too low	Re-adjust the proportion of raw materials; do not replace sugar with sweeteners
No slush comes out from outlet	Too much ice in the hopper	Turn off and let the ice melt
Slush has black stains	The hopper is not cleaned well	Re-clean
	Beater seals are dirty	Re-clean
	Beater seals are damaged	Replace with new seals
1RH/2RH/3RH Alarm	The corresponding hopper temperature sensor is broken	Replace sensor

If the machine failure is not caused by the above reasons or the above suggestions cannot solve the failure, please contact an authorised service centre.

Specifications

Capacity	6L
Voltage	240V
Refrigerant	R290
Power	400W
Compressor	Danfu
Body Material:	Stainless Steel

Note: Minimal Assembly required



Some experts believe that the incorrect or prolonged use of almost any product may cause serious injury or death. To help reduce your risk of serious injury or death, refer to the information below. For more information, see www.datastreamserver.com/safety

- Consult all documentation, packaging, and product labelling before use. Note that some products feature documentation available online. It is recommended to print and retain the documentation.
- Before each use, check the product for loose/broken/damaged/missing parts, wear, or leaks (if applicable). Never use a product with loose/broken/damaged/missing parts, wear, or leaks.
- Products must be inspected and serviced (if applicable) by a qualified technician every 6 months. This is based on average residential use by persons of average size and strength, and on a property of average metropolitan size. Use beyond these recommendations may require more frequent inspections/servicing.
- Ensure that all users of the product have completed a suitable industry recognised training course before being allowed access to the product.
- The product has been supplied by a general merchandise retailer that may not be familiar with your specific application or description of application. Be sure to attain third-party approval from a qualified specialist for your application before use, regardless of any assurances from the retailer or its representatives.
- This product is not intended for use where fail-safe operation is required. As with any product (for example, automobile, computer, toaster), there is the possibility of technical issues that may require the repair or replacement of parts, or the product itself. If the possibility of such failure and the associated time it may take to rectify could in any way inconvenience the user, business, or employee, or financially affect the user, business, or employee, then the product is not suitable for your requirements. This product is not intended for use where incorrect operation or a failure of any kind, including but not limited to, a condition requiring product return, replacement, parts replacement, or service by a technician may cause financial loss, loss of employee time or an inconvenience requiring compensation.
- If this product has been purchased in error when considering the information presented here, contact the retailer directly for details of their returns policy, if required.

