



INVERTER GENERATOR



User Manual

[Revision 1.0]

READ THIS MANUAL CAREFULLY BEFORE USE – FAILURE TO DO SO MAY RESULT IN INJURY, PROPERTY DAMAGE AND MAY VOID WARRANTY. • KEEP THIS MANUAL FOR FUTURE REFERENCE. • Products covered by this manual may vary in appearance, assembly, inclusions, specifications, description, and packaging.

The product is NOT supplied with engine oil, although traces of oil from the manufacturing process may be present. It is essential to add adequate engine oil of the correct type to the engine before use. **Failure to add engine oil will void the product warranty.**

Safety

Safety messages are designed to alert you to possible dangers or hazards that could cause death, injury or equipment or property damage if not understood or followed. Safety messages have the following symbols:



You **WILL** be **KILLED** or **SERIOUSLY INJURED** if you do not follow instructions.



You **CAN** be **KILLED** or **SERIOUSLY INJURED** if you do not follow instructions.



You **CAN** be **INJURED** if you do not follow instructions or equipment damage may occur.

It is vital that you read and understand this user manual before using the product, including safety warnings, and any assembly and operating instructions. Keep the manual for future reference.

Safety precautions and recommendations detailed here must be fully understood and followed to reduce the risk of injury, fire, explosion, electrical hazard, and/or property damage.

Safety information presented here is generic in nature – some advice may not be applicable to every product. The term "equipment" refers to the product, be it electrical mains powered, battery powered or combustion engine powered.

- **Before Use** - If you are not familiar with the safe operation/handling of the equipment or are in any way unsure of any aspect of suitability or correct use for your application, you should complete training conducted by a person or organization qualified in safe use and operation of this equipment, including fuel/electrical handling and safety.
- Do NOT operate the equipment in flammable or explosive environments, such as in the presence of flammable liquids, gases, or dust. The equipment may create sparks or heat that may ignite flammable substances.
- Keep clear of moving parts.
- Equipment may be a potential source of electric shock or injury if misused.
- Do NOT operate the equipment if it is damaged, malfunctioning or is in an excessively worn state.
- Do NOT allow others to use the equipment unless they have read this manual and are adequately trained.
- Keep packaging away from children - risk of suffocation! Operators must use the equipment correctly. When using the equipment, consider conditions and pay due care to persons and property.

General Work Area Safety

- Work areas should be clean and well lit.
- Do not operate the equipment if bystanders, animals etc are within operating range of the equipment or the general work area.
- If devices are provided for connecting dust extraction / collection facilities, ensure these are connected and used properly. Dust collection can reduce dust-related hazards.

General Personal Safety

- Wear appropriate protective equipment when operating, servicing, or when in the operating area of the equipment to help protect from eye and ear injury, poisoning, burns, cutting and crush injuries. Protective equipment such as safety goggles, respirators, non-slip safety footwear, hard hat, hearing protection etc should be used for appropriate equipment / conditions. Other people nearby should also wear appropriate personal protective equipment. Do not wear loose clothing or jewellery, which can be caught in moving parts. Keep hair and clothing away from the equipment.
- Stay alert and use common sense when operating the equipment. Do not over-reach. Always maintain secure footing and balance.
- Do not use the equipment if tired or under the influence of drugs, alcohol, or medication.
- This equipment is not intended for use by persons with reduced physical, sensory, or mental capabilities.

General Fuel Safety

- Petrol/fuel/gasoline is extremely flammable – keep clear of naked flames or other ignition sources.
- Do not spill fuel. If you spill fuel, wipe it off the equipment immediately – if fuel gets on your clothing, change clothing.
- Do NOT smoke near fuel or when refuelling.
- Always shut off the engine before refuelling.
- Do NOT refuel a hot engine.
- Open the fuel cap carefully to allow any pressure build-up in the tank to release slowly.
- Always refuel in well-ventilated areas.
- Always check for fuel leakage. If fuel leakage is found, do not start, or run the engine until all leaks are fixed.

General Carbon-Monoxide Safety

- Using a combustion engine indoors **CAN KILL IN MINUTES**. Engine exhaust contains carbon-monoxide – a poison you cannot smell or see.
- Use combustion engines **OUTSIDE** only, and far away from windows, doors, and vents.

General Equipment Use and Care

- Keep packaging away from children and pets, potential risk of suffocation or choking.
- The equipment is designed for domestic use only.
- Handle the equipment safely and carefully.
- Before use, inspect the equipment for misalignment or binding of moving parts, loose components, damage, or any other condition that may affect its operation. If damaged, have the equipment repaired by an authorised service centre or technician before use.
- Prevent unintentional starting of the equipment - ensure equipment and power switches are in the OFF position before connecting or moving equipment. Do not carry equipment with hands or fingers touching any controls. Remove any tools or other items that are not a part of the equipment from it before starting or switching on.
- Do not force the equipment. Use the correct equipment for your application. Equipment will perform better and be safer when used within its design and usage parameters.
- Use the equipment and accessories etc. in accordance with these instructions, considering working conditions and the work to be performed. Using the equipment for operations different from those intended could result in hazardous situations.
- Always keep equipment components (engines, hoses, handles, controls, frames, housings, guards etc) and accessories (cutting tools, nozzles, bits etc) properly maintained. Keep the equipment clean and, where applicable, properly lubricated.
- Store the equipment out of reach of children or untrained persons. To avoid burns or fire hazards, let the equipment cool completely before transporting or storing. Never place or store the equipment near flammable materials, combustible gases, or liquids etc.
- The equipment is not weather-proof, and should not be stored in direct sunlight, at high ambient temperatures or locations that are damp or humid.
- Do not clean equipment with solvents, flammable liquids, or harsh abrasives.
- For specific equipment safety use and care, see Equipment Safety.

General Electrical Safety

- Inspect electrical equipment, extension cords, power bars, and electrical fittings for damage or wear before each use. Repair or replace damaged equipment immediately.
- Ensure all power sources conform to equipment voltage requirements and are disconnected before connecting or disconnecting equipment.
- When wiring electrically powered equipment, follow all electrical and safety codes.
- Always use a Residual Current Device (RCD) (GFCI) / Earth Leakage Circuit Breaker / Safety Switch when operating this item (electrical items only).
- High voltage / high current power lines may be present. Use extreme caution to avoid contact or interference with power lines. Electrical shock can be fatal.

General Electrical Safety

- Electrically grounded equipment must have an approved cord and plug and be connected to a grounded electrical outlet.
- Do NOT bypass the ON/OFF switch and operate equipment by connecting and disconnecting the electrical cord.
- Do NOT use equipment that has exposed wiring, damaged switches, covers or guards.
- Do NOT use electrical equipment in wet conditions or in damp locations.
- Do NOT use electrical cords to lift, move or carry equipment.
- Do NOT coil or knot electrical cords, and ensure electrical cords are not trip hazards.

General Service Information

- The equipment must be serviced or repaired at authorised service centres by qualified personnel only.
- Replacement parts must be original equipment manufacturer (OEM) to ensure equipment safety is maintained.
- Do NOT attempt any maintenance or repair work not described in this manual.
- After use, the equipment and components may still be hot – allow the equipment to cool and disconnect spark plugs and/or electrical power sources and/or batteries from it before adjusting, changing accessories, or performing repair or maintenance.
- Do NOT adjust while the equipment is running.
- Perform service-related activities in suitable conditions, such as a workshop.
- Replace worn, damaged or missing warning/safety labels immediately.

Child Choking Hazard!



• WARNING: CHOKING HAZARD - CHILDREN UNDER 8 YRS. CAN CHOKE OR SUFFOCATE ON SMALL PARTS. ADULT SUPERVISION REQUIRED.

- Carefully inspect anything a baby or child could gain access to, including this product & packaging.
- Dangers include anything of a size that could become stuck or lodged in a baby or child's airway.
- Dangers include things like raw, hard fruit and vegetable pieces, large pieces of meat, bones or sausage skins, popcorn, nuts, hard lollies and corn chips, small magnets and batteries, coins, beads, marbles and small uninflated balloons, broken toys and smaller toys, buttons, keys, and coins. But there are also many more.
- Pay particular attention to accessories, nuts, bolts, screws, washers, caps, covers, loose parts, parts that could be removed or break off, pieces of packaging, staples, tape etc.
- In the case of any doubt, secure the item of concern in an appropriate manner, or completely remove the possibility of access by a baby or child.

Inverter Generator Safety

⚠ DANGER ⚠

Using an engine or wood/charcoal/gas fuelled appliance indoors CAN KILL YOU IN MINUTES. Engine exhaust and wood/charcoal/gas fumes contain carbon monoxide. This is a poison you cannot see or smell.

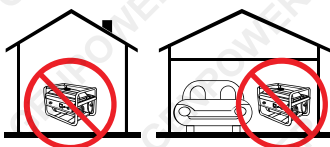

NEVER use inside a building, home, garage, boat, caravan or tent EVEN IF doors and windows are open.

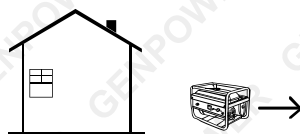

Only use OUTSIDE and far away from windows, doors, and vents.

Avoid other hazards - READ MANUAL BEFORE USE.

GENERAL:

- Do not operate in a hazardous location. Such areas include where there is a risk of explosion of petrol fumes, leaking gas or explosive dusts.
- Do not operate in a confined area where exhaust gases or wood/charcoal/gas fumes could reach dangerous concentrations.

PRODUCTS FEATURING AN ENGINE

- Follow all warnings in the section titled "GENERAL".
- Explosion hazard - never smoke while refuelling.
- Take care not to spill fuel. When refuelling the engine, ensure that the engine has been allowed to cool. Prevent spilling of fuel as this may also ignite with a hot engine.
- Never refuel while engine is running.

GENERATORS

- Follow all warnings in the sections titled "GENERAL" and "PRODUCTS FEATURING AN ENGINE".
- The output of this generator is potentially lethal. The generator should not be connected to a fixed electrical installation except by an appropriately licensed person.
- Not weatherproof – protect your machine. This machine is not weatherproof and should not be exposed to direct sunlight, high ambient temperature, damp conditions, wet conditions or high humidity conditions.

- **WARNING! FAILURE TO FOLLOW THE INSTRUCTIONS IN THIS MANUAL MAY RESULT IN SERIOUS EQUIPMENT DAMAGE, PERSONAL INJURY, OR DEATH.**
- Be sure to read all labels and manuals carefully before using the unit.
- Please use this product in a well-ventilated area, as the exhaust contains toxic carbon monoxide, which can be fatal.
- Be sure to turn off the engine when replenishing fuel and wait 5 minutes before restarting. Check for any fuel leaks or spills. If detected, clean or repair it before use. Do not place other flammable materials or items near the engine.
- Notice! If you have any questions, please contact your dealer.
- **CAUTION! GENERATORS ARE SAFE AND RELIABLE AS LONG AS YOU FOLLOW THE INSTRUCTIONS IN THIS MANUAL. READ AND UNDERSTAND THE MANUAL BEFORE USE. INCORRECT OPERATION MAY CAUSE PERSONAL INJURY OR DAMAGE TO THE DEVICE.**

GP3600i Inverter Generator

- Instructions may vary depending on the generator type and configuration. Please read and understand the instructions carefully before operating the generator. Only when you are familiar with the safe operation procedures of the generator can you avoid accidents.

DO NOT USE INDOORS

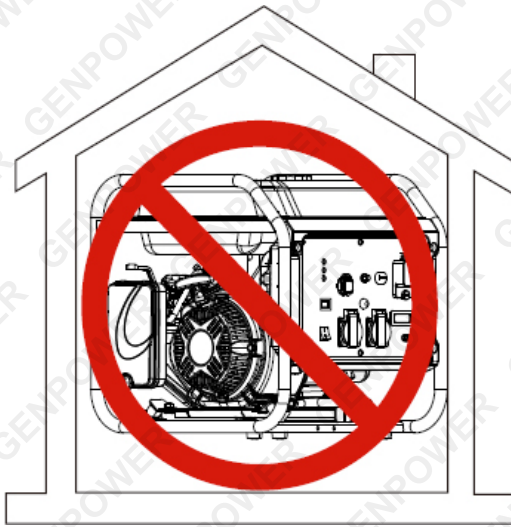

DO NOT USE IN HUMID ENVIRONMENTS

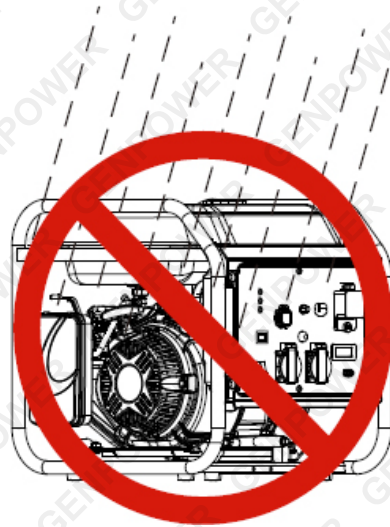

DO NOT CONNECT DIRECTLY TO HOME CIRCUIT

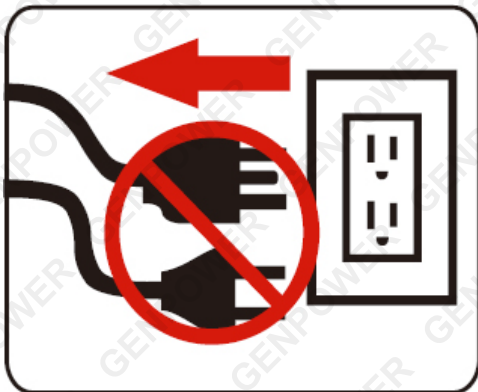

KEEP COMBUSTIBLE MATERIALS 5M AWAY

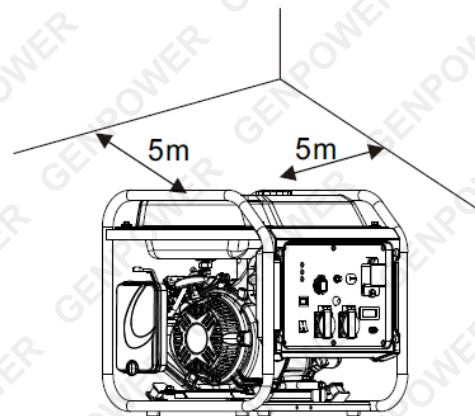

NO SMOKING WHILE ADDING FUEL

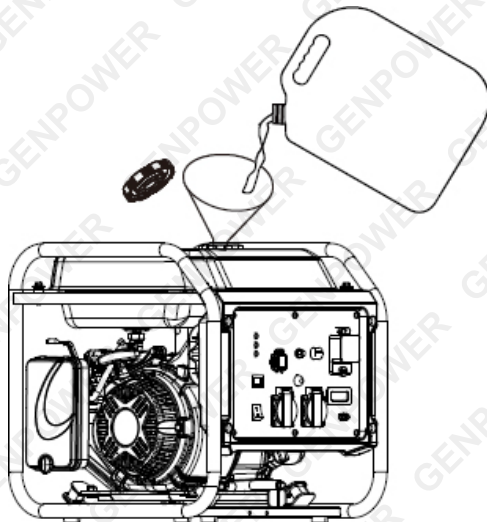

SHUT OFF THE ENGINE WHILE ADDING FUEL

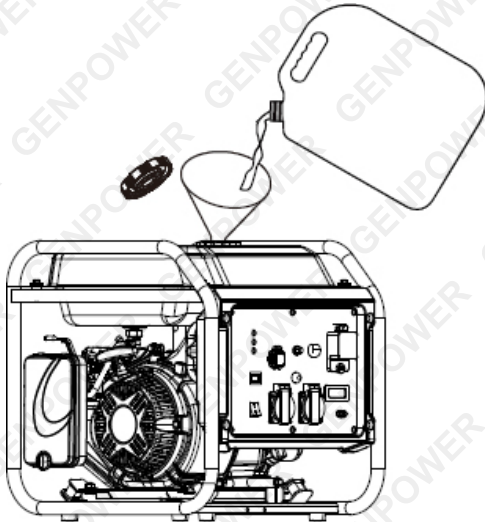

DO NOT OVERFILL

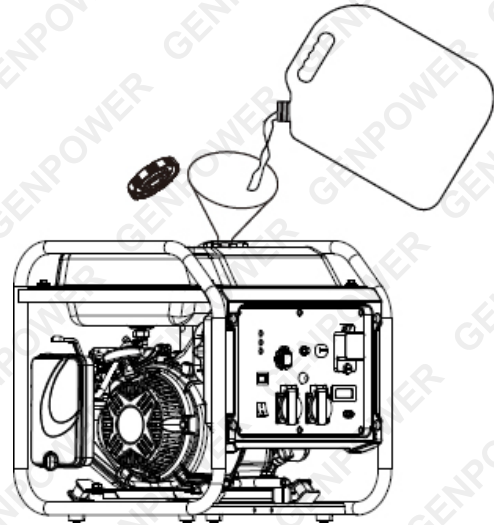

- **Connect to the Home Power Supply.** When connecting the generator to the home power supply as a backup power source, the connection should be made by a professional electrician or someone familiar with electrical systems. After connecting the load to the generator, carefully check that the electrical connection is secure. An incorrect electrical connection may cause damage to the generator, result in burning, fire, or even explosion.

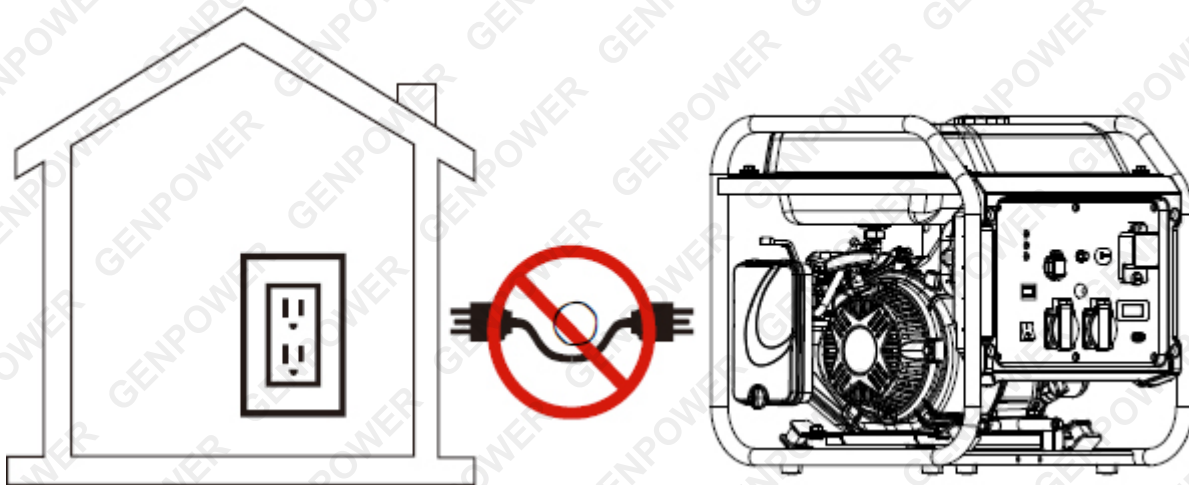

- **Grounding.** To prevent electric shock caused by faulty electrical appliances or improper use of electricity, the generator should be grounded with a well-insulated wire.

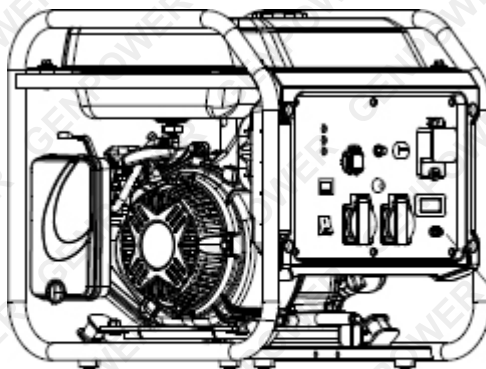

GROUNDING























GP3600i Inverter Generator

- The air filter, starting tray, muffler exhaust port, inverter air intake port, and motor air intake port should remain ventilated and free from debris, mud, water, particles, and excessive dust. If these vents become blocked, the engine, frequency converter, or motor may be damaged. Do not place other objects on or near the generator when handling, storing, or using it. If the generator leaks, it could damage the engine or your property.

Safety Symbols

The product may have safety warning labels attached to it, explained below. Understand the symbols on your product and their meanings. If any stickers become unreadable, unattached etc., replace them.

 <p>Flammable Material Hazard Flammable liquids, gases, or substances etc may present. Avoid ignition sources and open flames. Danger of fire.</p>	 <p>Read User Manual Read and fully understand product safety warnings, operation, procedures etc before using the product.</p>	 <p>Use Hand Protection Wear appropriate hand protection and take due care as the product or use of the product may present hand hazards.</p>	 <p>Carbon-Monoxide Hazard Do not use the product in confined areas or without adequate ventilation. Carbon-monoxide poisoning can be fatal.</p>
 <p>Electrocution / Electrical Shock Hazard High voltage or high current electricity may be present or required by the product. Take due care when handling electrical products, cables, plugs and leads. Electrical shock can be fatal.</p>	 <p>Toxic Fumes / Dust Hazard Using the product or by-products from use may produce fumes, smoke or particles that could be harmful if inhaled. Wear appropriate breathing protection and have adequate ventilation.</p>	 <p>Explosive Material Hazard Combustible liquids, gases, or substances etc may be present. Avoid ignition sources and open flames. Danger of explosion.</p>	 <p>Cutting / Amputation Hazard The product may have blades, edges or mechanical devices that can cause severe cut injury to fingers, limbs etc. Take due care when handling and using the product.</p>
 <p>Crush Hazard The product may have blades, edges or mechanical devices that can cause severe crush injury to fingers, limbs etc. Take due care when handling and using the product.</p>	 <p>Single Operator Only The product must be operated by a single person only. More than one person operating the product may introduce additional hazards.</p>	 <p>Use Face Protection Wear appropriate full-face protection and take due care as the product or use of the product may present face and eye hazards.</p>	 <p>Use Foot Protection Wear appropriate foot protection and take due care as the product or use of the product may present foot hazards.</p>
 <p>Use Eye / Ear / Head Protection Wear appropriate eye and / or ear and / or head protection and take due care as the product or use of the product may present eye, hearing, and head hazards.</p>	 <p>Running Hazard Do not run on or near the product as doing so may present a fall hazard.</p>	 <p>Diving Hazard Do not dive into the product as doing so may present a neck / head injury hazard.</p>	 <p>Adult Supervision Required Always supervise children and other users of a product to prevent drowning or injury.</p>
 <p>Skin Penetration / Puncture Hazard The product may produce pressure, emit liquids or objects that can cause severe injury to fingers, limbs, blood etc. Take due care when handling and using the product.</p>	 <p>Hot Surface Hazard Be aware that the product may produce high temperatures and hot surfaces that can cause burn injuries.</p>	 <p>Flying Debris Hazard Be aware that the product or use of the product may present hazards produced by flying debris. Wear appropriate clothing and protective devices.</p>	 <p>Moving Parts Hazard Be aware that the product contains or uses mechanical devices that move or rotate. Always wait for moving parts to stop fully before handling the product, adjusting, maintenance etc.</p>





 <p>Carbon-Monoxide Hazard Do not use the product in confined areas or without adequate ventilation. Carbon-monoxide poisoning can be fatal.</p>	 <p>Pull Hazard Be aware that the product contains or uses mechanical devices that can pull in objects and can cause severe injury to fingers, limbs etc. Take due care when handling and using the product.</p>	 <p>Slope / Fall Injury Hazard Be aware that using the product on sloping surfaces or in slippery conditions may present additional dangers from falls and contact with blades, moving parts, hot surfaces etc.</p>	 <p>"Slam Dunk" Warning Do NOT attempt "slam dunk" manoeuvres as this may result in severe injury due to falling, product breakage or collapse etc.</p>
 <p>Electrocution / Electrical Shock Hazard - Outdoor High voltage or high current electricity may be present or required by the product. Do NOT use in rain, damp, or wet conditions. Electrical shock can be fatal.</p>	 <p>Electrocution / Electrical Shock Hazard - Disconnect High voltage or high current electricity may be present or required by the product. Always disconnect the product from the electrical supply before handling the product, adjusting, maintenance etc.</p>	 <p>Power Line Electrocution Hazard High voltage / high current power lines may be present. Use extreme caution to avoid contact or interference with power lines. Electrical shock can be fatal.</p>	 <p>"Kick-Back" Hazard High level of "kick-back" hazard that can cause the machine to suddenly rotate towards operator. Kick-back injury can be fatal.</p>
 <p>Winch Operator Position Hazard Do NOT stand between winch and load. Do NOT use winch to move people.</p>	 <p>Winch Lift Hazard Do NOT LIFT load vertically. Use machine to PULL only.</p>	 <p>Cable Hazard Ensure that load bearing cable is not kinked or knotted.</p>	 <p>Winch Cable Hazard Ensure that there is a minimum number of cable coils on winching mechanism.</p>
 <p>Winch Hook Hazard Carry hook to load – do NOT throw or run.</p>	 <p>Flash / Blinding Hazard Wear appropriate eye protection for welding. Direct exposure to weld arcs may cause permanent eye injury.</p>	 <p>Laser Hazard Laser may be in use – do NOT look directly at laser or allow others to.</p>	 <p>Choking Hazard Children under 8 yrs. Can choke or suffocate on small parts. Adult supervision required.</p>

Table of Contents

Safety	2
Safety Symbols	7
Parts Identification	10
Control Functions	11
ON/OFF Switch	11
Fuel Switch	11
Choke Switch	11
Preparation	12
Economy Switch (ECO)	12
Fuel Cap	12
Grounding Terminal	13
Adding Fuel	13
Engine Oil	14
Checks Before Operation	15
Fuel	15
Engine Oil	15
Operation	15
Standard Atmospheric Conditions	15
Operation	16
Starting the Generator (Recoil Start)	16
Open Choke Valve	16
Connecting the Load	17
Stop the Engine Off Load	17
Turn Off Engine Switch	18
AC Connecting	18
Battery Charging (if equipped)	19
Maintenance	20
Regular Spot Inspection and Maintenance	20
Maintenance Schedule	20
Spark Plug Check	21
Replace Engine Oil	22
Air Filter	23
Muffler Enclosure and Spark Arrestor Net	24
Fuel Tank Filter	24
Storage	25
Troubleshooting	27
Specifications	28

Parts Identification

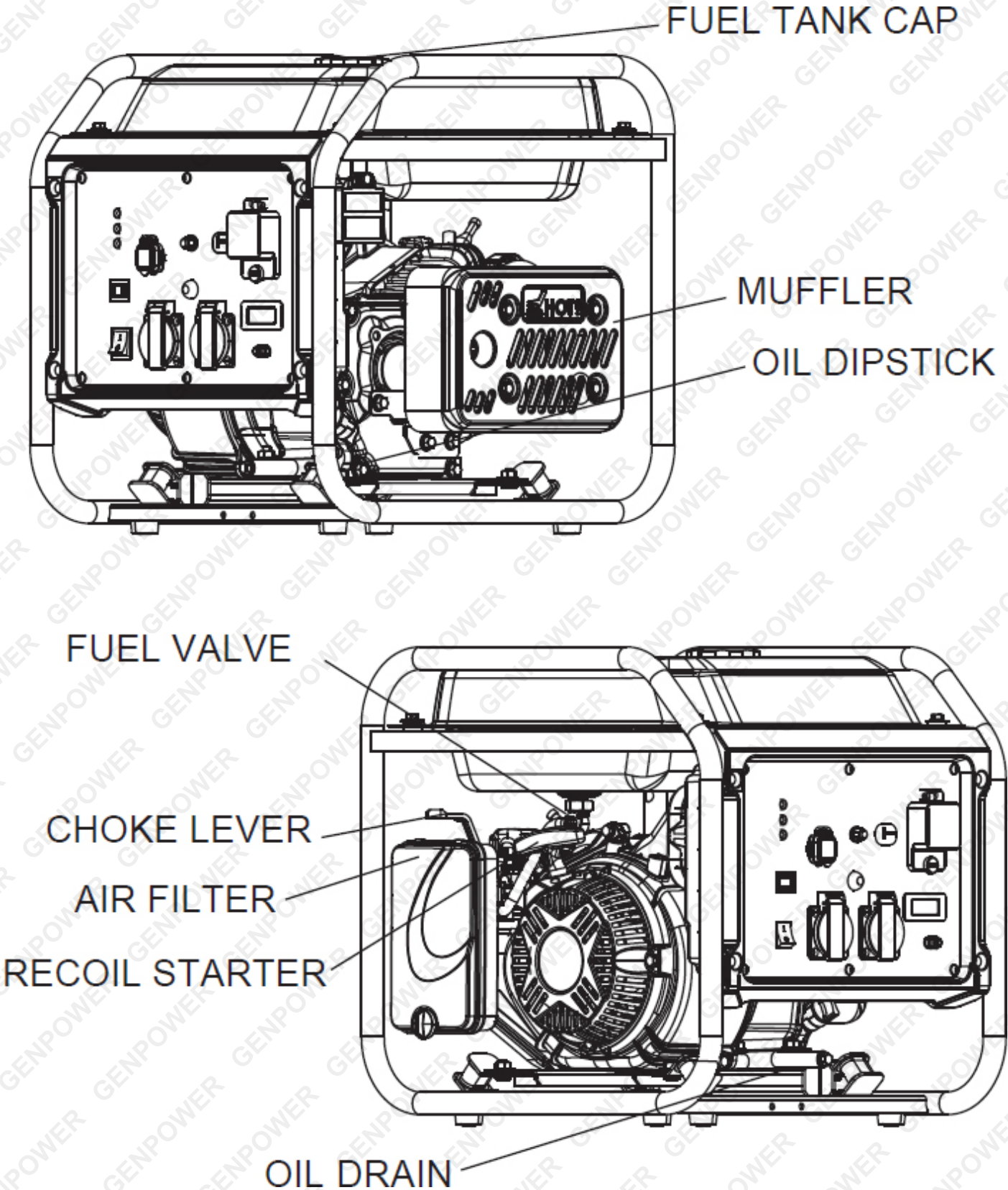

Control Functions

ON/OFF Switch

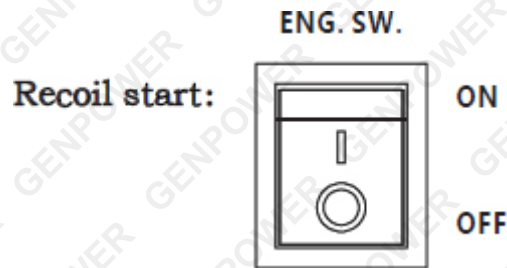

- Used to start and shut down the engine. When not in use, set the switch to the "Stop" position. The ON/OFF switch must be set to the "ON" position when starting the engine.
- Stop: The machine is in a shutdown state.

Fuel Switch



When the switch is in the "ON" position, fuel flows from the tank through the fuel switch and into the carburettor. When shutting down, ensure the fuel switch is in the "OFF" position.

Choke Switch



- Used to control the air flow into the cylinder during startup.
- Choke Closed: When the unit is cold, set the choke to the "CHOKE" position. If the unit is warm, set it halfway.
- If the generator does not start after two attempts, set the choke to the "Run" position and then operate the switch or pull the starter manually.
- Choke Operation: The choke should be open when the machine is running.

Preparation

Economy Switch (ECO)

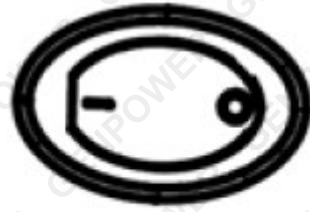

OFF ◀ ▶ ON

- On: When the economy switch is set to the "On" position, the engine operates at a speed of 2600–3800 r/min. During operation, the speed gradually increases according to the load, optimising fuel consumption and reducing noise.
- Off: When the economy switch is set to the "Off" position, the engine speed ranges from 3100–3800 r/min. During operation, the engine speed gradually increases in response to the load.

Reminder: When using equipment with impact loads, such as an air compressor or submersible water pump, the economy switch must be turned to the "Off" position due to the need for a larger starting current.

Fuel Cap



Remove the fuel cap by turning it counterclockwise.

Grounding Terminal

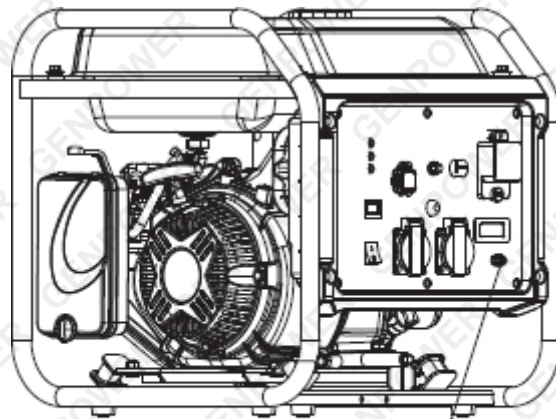

Grounding

When connecting the ground terminal to the grounding wire, ensure proper grounding to prevent electric shock. If any electrical equipment is grounded, the generator must also be grounded.

NOTE: Grounding wire not included.

Adding Fuel

DANGEROUS! FUEL IS FLAMMABLE AND TOXIC! Please read the safety instructions carefully before refuelling). Do not overfill the tank. After refuelling, ensure the fuel tank cover is tightened.

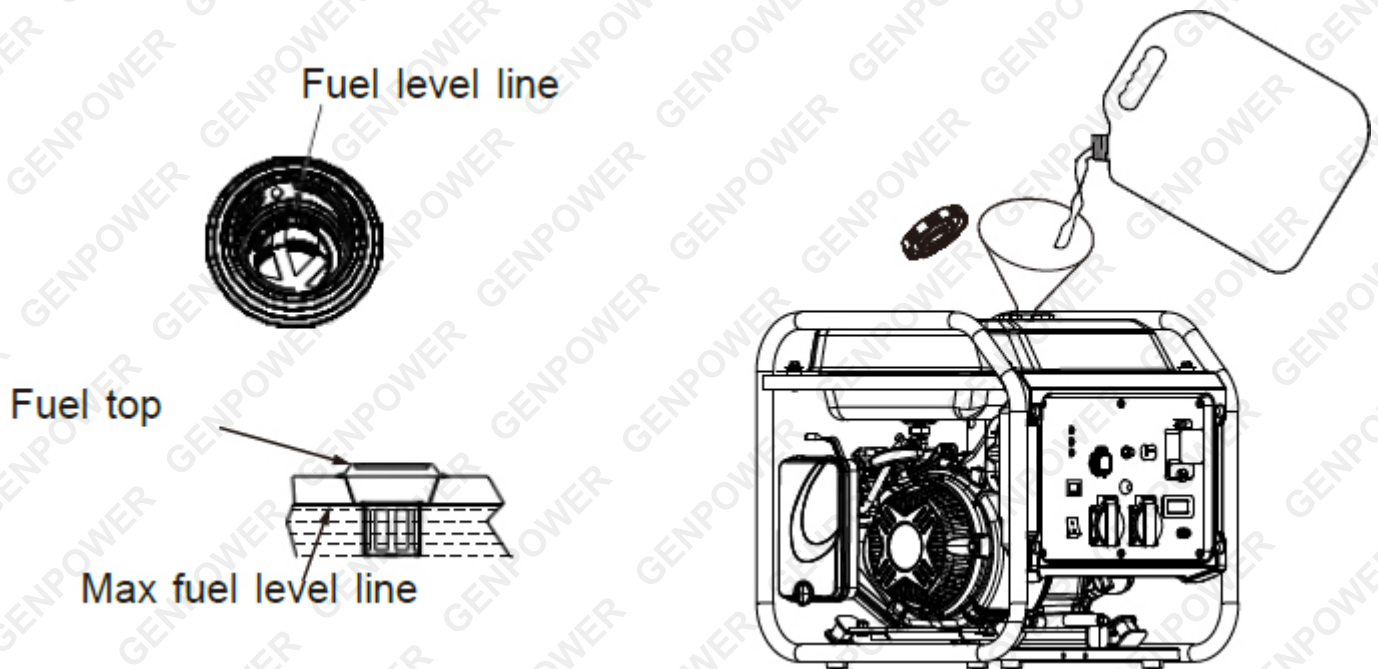

1. After adding fuel, wipe away any spilled petrol with a clean, soft cloth to avoid damaging the plastic casing.
2. Only unleaded petrol must be used. Leaded petrol can seriously damage the internal parts of the engine.
3. Remove the fuel tank cap and add petrol to the indicated fuel level.

Suggested Fuel: Unleaded petrol

Engine Oil

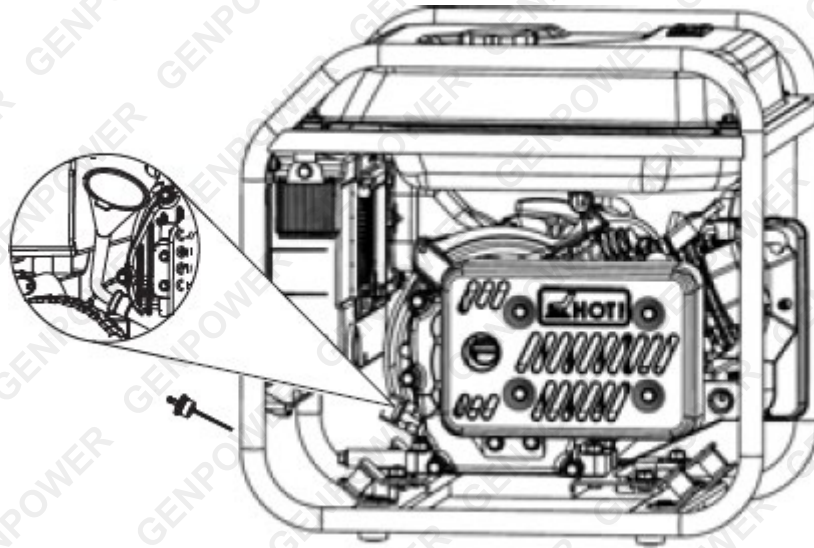

The generator is not filled with oil when delivered from the factory. Do not start the generator before filling it with enough oil, as this will damage the generator.

1. Place the generator on a level surface.
2. Unscrew the oil dipstick.
3. Add the recommended engine oil and tighten the dipstick.

Suggested Engine Oil: SAE 10W-30

Suggested Engine Oil Grade: API Standard SE Type

Checks Before Operation

WARNING! If any of the following parts do not function properly, inspect and repair the engine carefully before starting it. Users should monitor the condition of the generator. Even when not in use, critical components of the generator can unexpectedly fail.

Tip: A pre-operation check should be performed every time the generator is used.

Fuel

1. Check the fuel line and fuel level in the tank.
2. Add fuel if necessary.

Engine Oil

1. Check the engine oil level.
2. Add engine oil to the required level if necessary.
3. Check for any engine oil leaks.

Operation

- Abnormalities during Operation: Monitor for any unusual conditions while the generator is running.
- Check Running Condition: Consult your dealer if necessary.

WARNING! Do not operate the generator in confined spaces. The exhaust gases can cause unconsciousness or even death within a short time. Always use the generator in a well-ventilated area. Do not connect any electrical equipment before starting the engine.

Notice! The engine is not filled with oil during transportation. Do not start the engine until it has been filled with sufficient oil. When adding oil, ensure the engine remains level to prevent underfilling or overfilling, which can damage the engine.

Note: The engine can operate at rated output load under standard atmospheric conditions.

Standard Atmospheric Conditions

- Ambient temperature: 25°C
- Atmospheric pressure: 100 kPa
- Humidity: 30%

The output of the generator may vary slightly depending on the ambient temperature, altitude (the higher the altitude, the lower the air pressure), and humidity. When temperature, humidity, and altitude exceed standard atmospheric conditions, the generator's output will decrease. Additionally, the load must be reduced if used in confined spaces where the generator's cooling is affected.

Operation

Starting the Generator (Recoil Start)

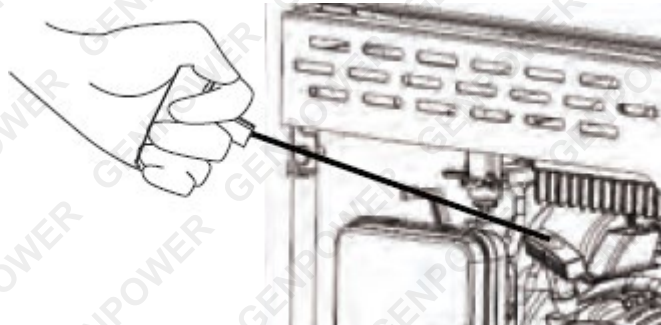

1. For a cold start, turn the choke switch to the fully closed position.
2. Gently pull the rope to engage the recoil starter with the engine's flywheel, then give the rope a sharp upward pull to start the generator. This should take no more than two attempts.
3. If the generator does not start, repeat the steps with the choke as needed.

Open Choke Valve

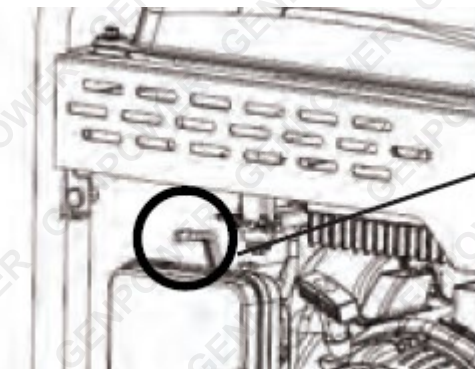

1. After the engine starts, move the choke switch to the "Run" position.
2. Let the generator run for 5 minutes without a load before connecting any electrical load.

Connecting the Load

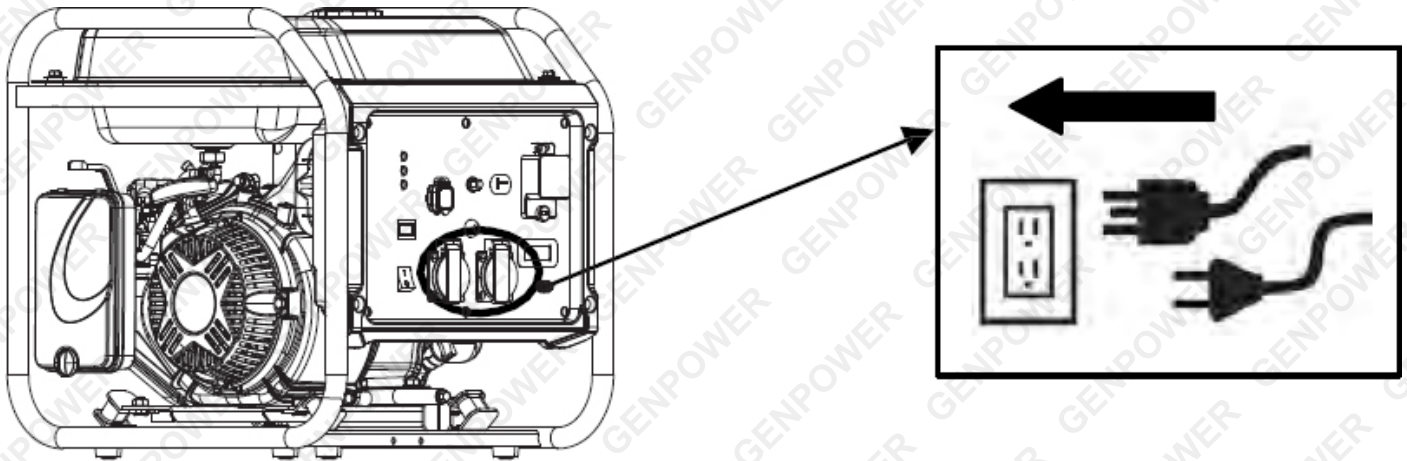

Connect the electrical equipment, then switch the circuit breaker protector to the "On" position.

Note: When using multiple loads, connect each additional load only after the previous one is running normally. The total power of the connected loads should not exceed the rated power of the generator.

Stop the Engine Off Load

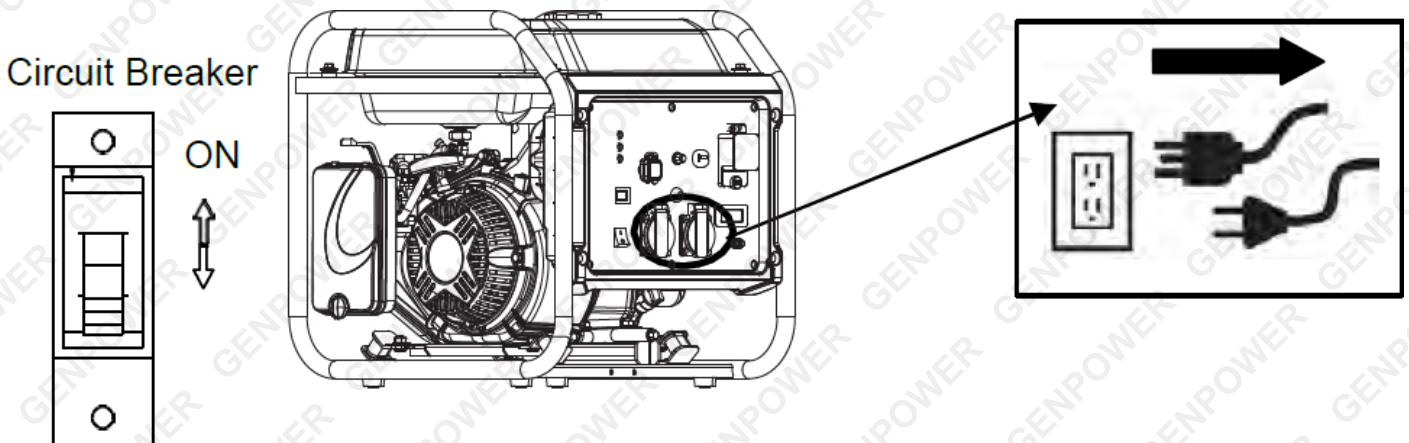

Turn off the circuit breaker by switching it to the "Off" position and disconnect the power settings from the generator control panel.

Turn Off Engine Switch

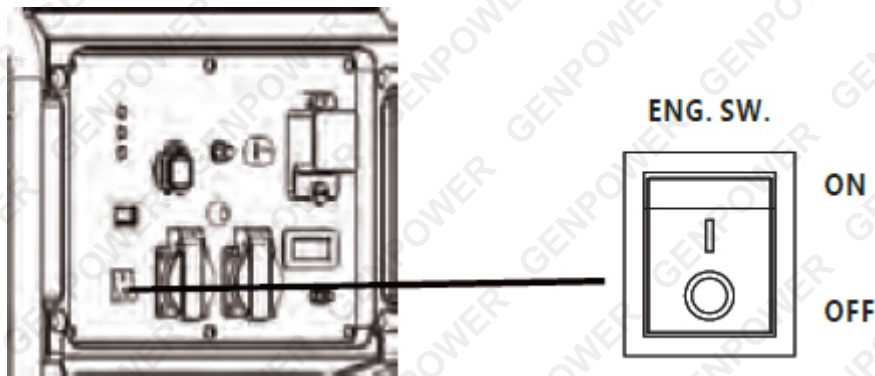

1. After the generator has run for 30 seconds without a load, turn off the engine switch. The generator will stop shortly after.
2. Ensure the engine switch is in the "Off" position to prevent the battery from discharging continuously.
3. When stopping the generator, turn the fuel switch to the "Off" position.

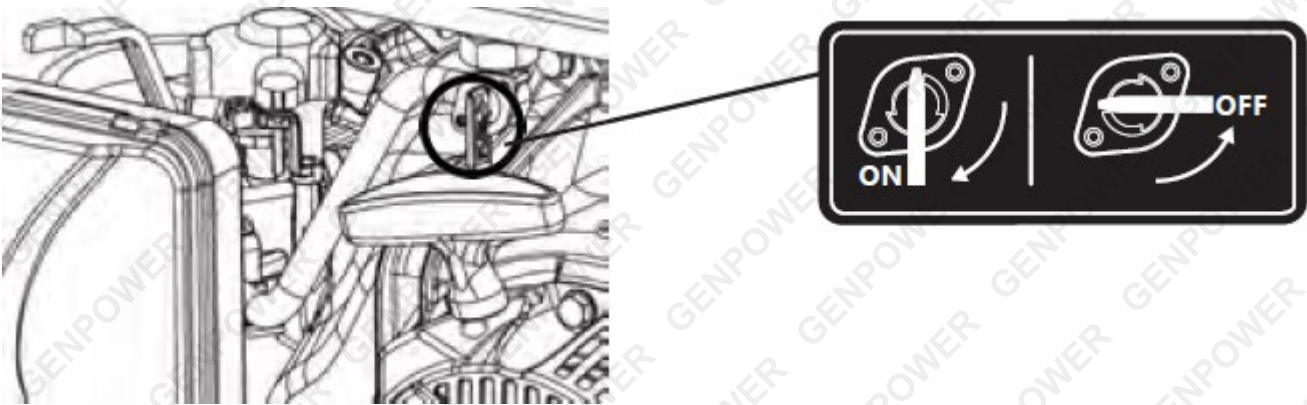

WARNING! After shutdown, the surface temperature of the generator remains very high. Allow the generator to cool down before moving or performing any other operations, as there is a risk of burns.

AC Connecting

All electrical equipment should be disconnected before inserting the plug. Ensure that all electrical equipment, including wires and plugs, are in good condition before connecting them to the generator. Ensure that the total load connected to the generator is within the rated range.

Notice! Verify that the load current is within the rated current range of the socket.

Note: Ensure that the generator is grounded. If any electrical equipment requires grounding, the generator must also be grounded.

1. Make sure the circuit breaker is turned off.
2. Start the generator.
3. Turn the ECO switch to the "On" position.
4. Confirm that the output indicator light is on.
5. Insert the plug into the AC socket.
6. Flip the circuit breaker handle to the "On" position (closed state).

7. Turn on the electrical equipment.

Note: The Power Saving mode switch must be turned to "Off" before increasing engine speed.

If the generator is powering multiple loads or electrical equipment, start the equipment in descending order based on the load size of each piece of equipment.

Battery Charging (if equipped)

Note: The rated DC voltage for this generator is 14V.

1. Connect the red wire to the positive (+) terminal of the battery.
2. Connect the black wire to the negative (-) terminal of the battery.
3. Start the generator.
4. Turn the ECO switch to the "Off" position and begin charging the battery.

Note: Ensure the economy (ECO) switch is in the "Off" position when charging the battery. Confirm that the red conductor of the charger is connected to the positive terminal (+) of the battery, and the black wire is connected to the negative terminal (-). Do not reverse the connections.

Ensure the charger cable and battery terminals are securely connected to prevent disconnection due to vibration or other circumstances. Follow the steps in the user manual to ensure correct operation.

NOTE: The user manual provides instructions to verify when charging is complete. Measure the electrolyte gravity to determine if the battery is fully charged. At full charge, the electrolyte's specific gravity should be between 1.26 and 1.28, and the voltage should be between 12.6V and 12.8V. If the voltage reads around 12.1V after charging, this is due to the battery's protection function. After using the battery, the voltage will return to approximately 12.6V.

WARNING! You are advised to check the electrolyte specific gravity and battery voltage at least once every hour to prevent overcharging. Do not smoke, or connect/disconnect the battery during charging, as the resulting sparks can ignite the gases around the battery. Battery electrolyte contains sulfuric acid, which is toxic and can cause burns. Avoid contact with skin, eyes, and clothing.

SOLUTION: For external contact, flush the affected area with plenty of water. If swallowed, drink plenty of water or milk, followed by milk, egg whites, or vegetable oil containing magnesium oxide. Call a hospital immediately. If it gets into your eyes, rinse thoroughly with water for 15 minutes and seek medical attention promptly. Batteries can produce explosive gases. Keep them away from sparks, flames, cigarettes, etc. Ensure the battery is well-ventilated when charging or when using it in a confined space. Close your eyes or wear protective gear when working near batteries. Keep batteries out of reach of children.

Maintenance

Regular Spot Inspection and Maintenance

- Users should operate the generator safely. Regular inspection, adjustment, and lubrication help ensure that the generator operates safely and efficiently. Below are the key inspection items for generators:
- If you are not familiar with maintenance work, please consult the designated dealer for service.

WARNING! Stop the generator before performing any maintenance.

Notice! Only use specified, authentic components for replacement. Contact the designated distributor for specific precautions.

Maintenance Schedule

Category	Check	Check Before Usage	Maintain	
			6M or 100H	12M or 300H
Spark Plug	Check, clean, or replace		○	
Engine Oil	Check oil line	○	☆	
Fuel Pipe	Check damage and replace	○		
Fuel	Check line replace	○		
Air Filter	Check, clean		△	
Muffler	Check, clean		○	
Spark Arrester	Check, clean		○	
Fuel Filter	Check, clean			○
Cylinder Head	Check, clean			▲
Valve Gap	Check and adjust			▲
Fasteners	Check if loose			▲

☆: First oil change should be done after the initial month or after 20 hours of operation.

△: The air filter should be checked and cleaned frequently, especially when used in damp and dusty environments, with maintenance recommended every 50 hours.

▲: These items should be maintained by designated dealers.

○: Indicates items that require regular inspection.

Spark Plug Check

The spark plug is a vital component of the generator and should be checked regularly.

1. Remove the spark plug maintenance cap and spark plug cap, and insert the socket into the hole from outside the cap.

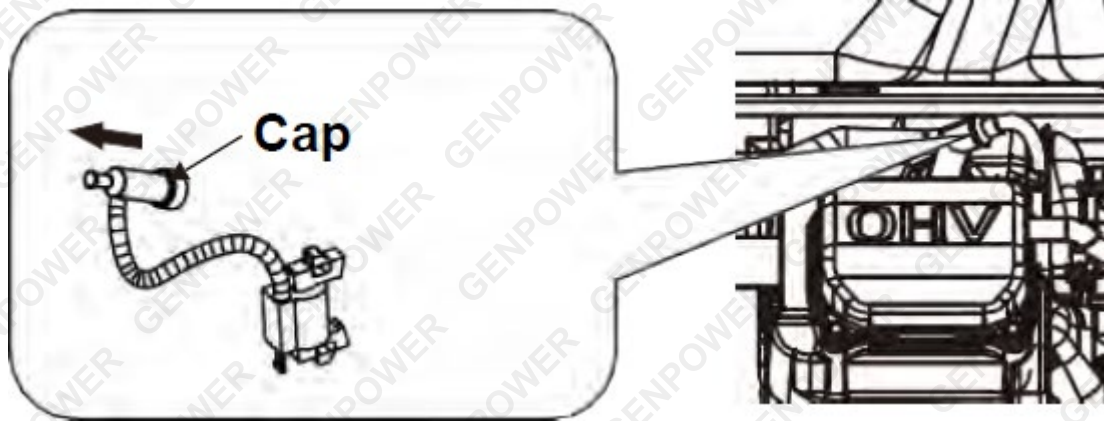

2. Insert the cylindrical rod into the socket and turn it counterclockwise to remove the spark plug.

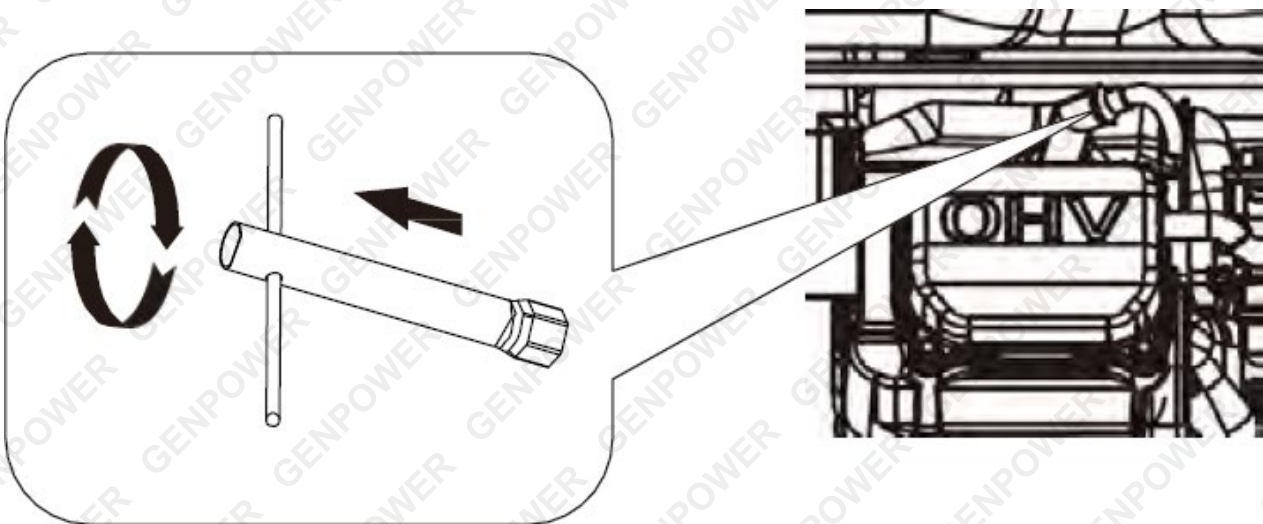

3. Check for fading or carbon deposits. The porcelain core around the spark plug's centre electrode should be a medium to light brown colour.
4. Check the spark plug model and gap:
 - Model No.: F7RTC
 - Spark Plug Gap: 0.6-0.8mm (0.024-0.031 inches)

Note: The spark plug gap should be measured with a feeler gauge and adjusted if necessary.

5. Spark Plug Assembly
 - Spark Plug Torque: 20.0 N.m (14.8 lbf.ft)

Note: If a torque wrench is unavailable when installing the spark plug, an estimate is to hand-tighten 1/4 to 1/2 turns.

6. Install the spark plug cap and cover.

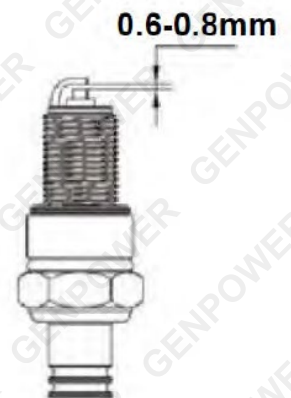

Replace Engine Oil

WARNING! Do not drain the oil immediately after shutting down the engine, as the oil temperature will be very high. Take care to avoid burns during this operation.

1. Place the generator on a level surface and run the generator for a few minutes to warm it up, then stop the generator.
2. Position an oil pan beneath the engine, unscrew the oil drain bolt, and quickly drain the oil.

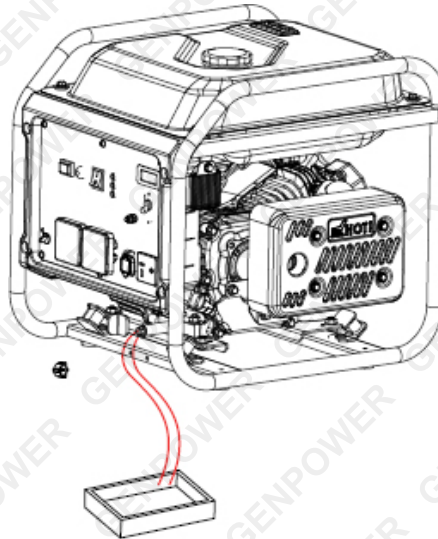

3. Tighten the drain bolt.
4. Unscrew the oil dipstick.

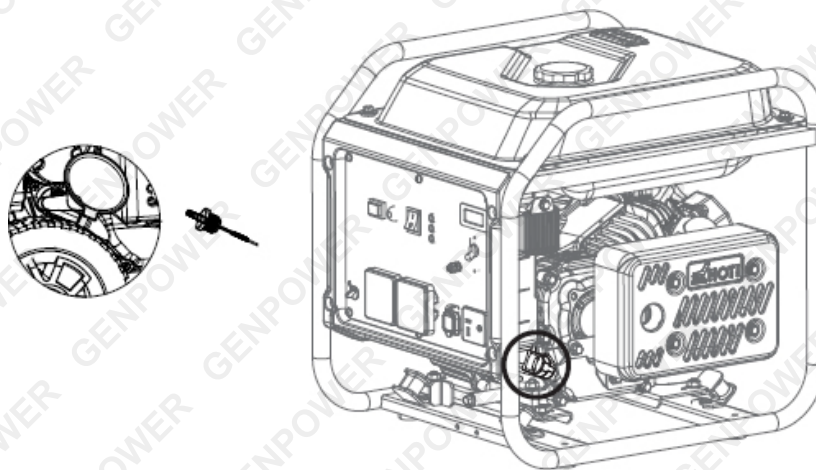

Note! Do not tilt the machine when adding oil to avoid overfilling or underfilling, which could damage the engine.

5. Add oil to the proper level.
 - Recommended Oil: SAE 10W-30
 - Oil Grade: API Standard SE or higher
6. Wipe the oil cap clean to remove any oil spills.

Note! Ensure no foreign matter enters the engine casing.

7. Tighten the oil dipstick.

Air Filter

1. Remove the bolt and take off the air filter cover.
2. Remove the foam filter element.
3. Clean the foam filter element with a solvent and allow it to dry.
4. Apply oil to the foam filter element and squeeze out any excess oil. The foam filter element should be damp but not dripping oil.

Notice! Do not twist the foam filter element forcefully to avoid damage.

5. Place the foam filter element back into the air filter housing.

Notice: Ensure the surface of the foam filter element fits snugly against the air filter without any gaps that could cause air leakage. Do not start the engine without an air filter, as this could lead to excessive gas production and cylinder wear.

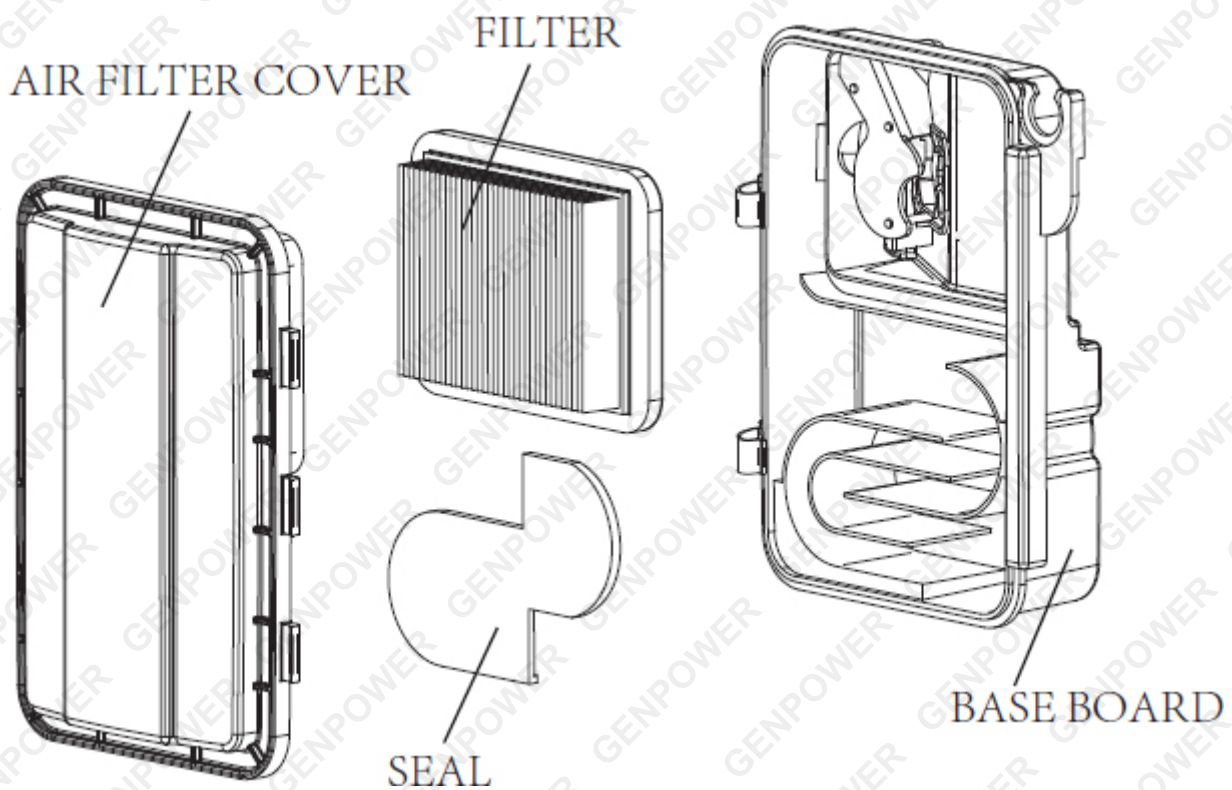

6. Reinstall the air filter cover in its original position and tighten the bolts.

Muffler Enclosure and Spark Arrestor Net

WARNING! The engine and muffler will become very hot after running. Avoid contact with the engine and muffler to prevent burns during inspection and maintenance.

1. Loosen the bolt and remove the muffler cover and spark arrestor net.

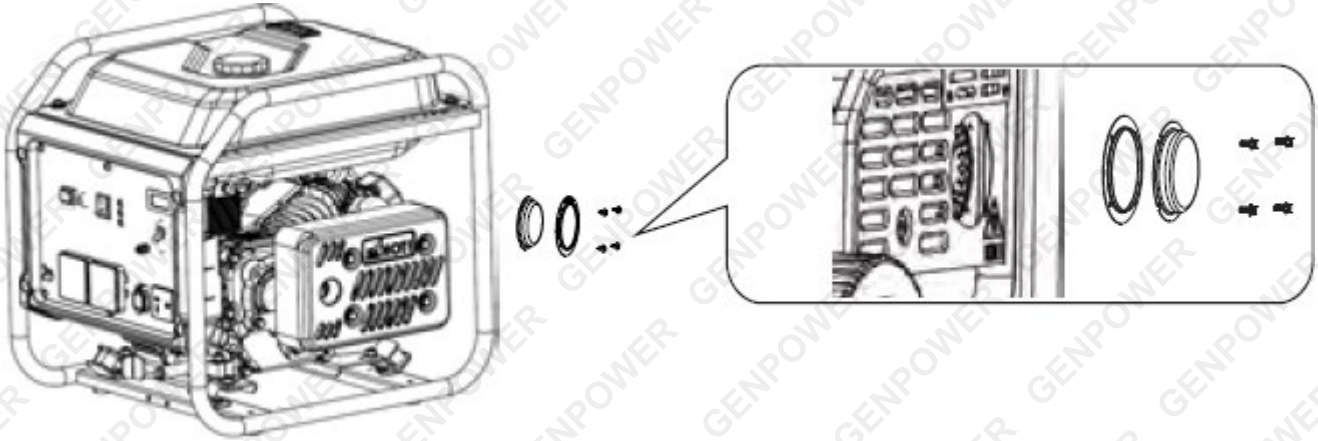

2. Use a wire brush to clean off any carbon deposits from the spark arrestor net.

Notice! Clean the spark arrestor net gently with a wire brush to avoid damaging or scratching it.

3. Inspect the spark arrestor net and replace it immediately if it is damaged.
4. Reinstall the spark arrestor net.
5. Reinstall the muffler enclosure.

Fuel Tank Filter

WARNING! Never handle gasoline near smoke or fire.

1. Remove the fuel cap and the fuel tank filter.
2. Clean the fuel tank filter using gasoline.
3. Dry the filter and return it to the fuel tank.
4. Reinstall the fuel tank cap.

Notice! Ensure the fuel tank cap is tightly secured.

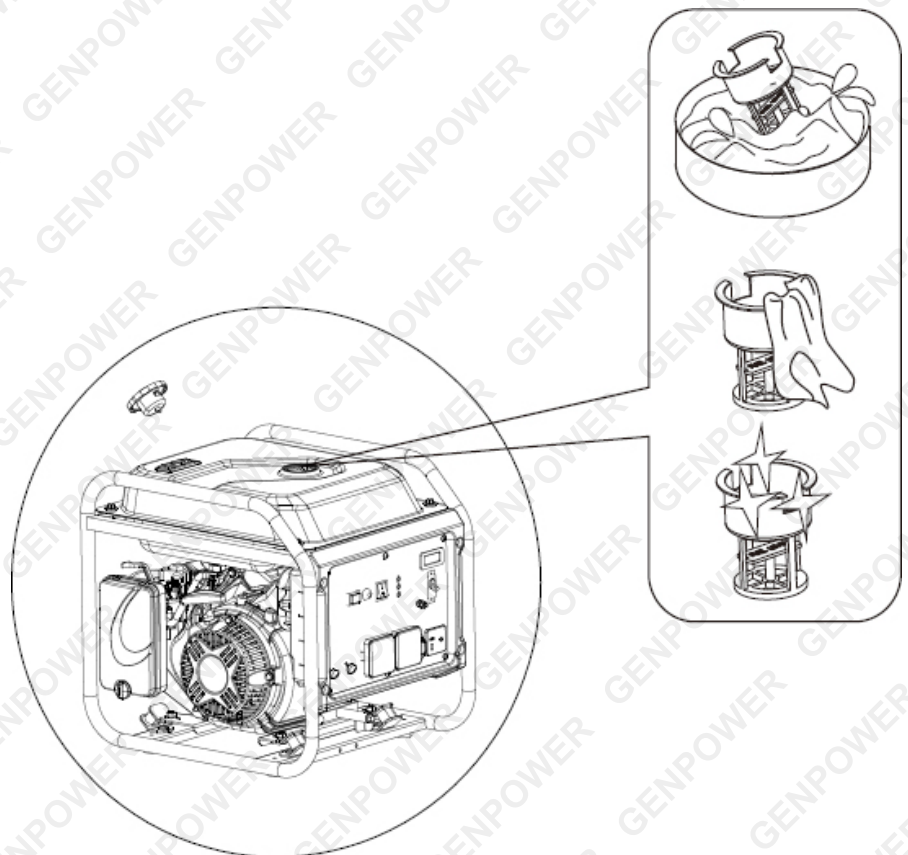

Storage

If you plan to store this generator for an extended period, certain measures are necessary to prevent deterioration.

Draining All Fuel

1. Turn the fuel switch knob to the "Off" position.



2. Open the fuel tank cap and remove the filter. Drain all fuel from the tank into a designated container, then securely tighten the tank cap.

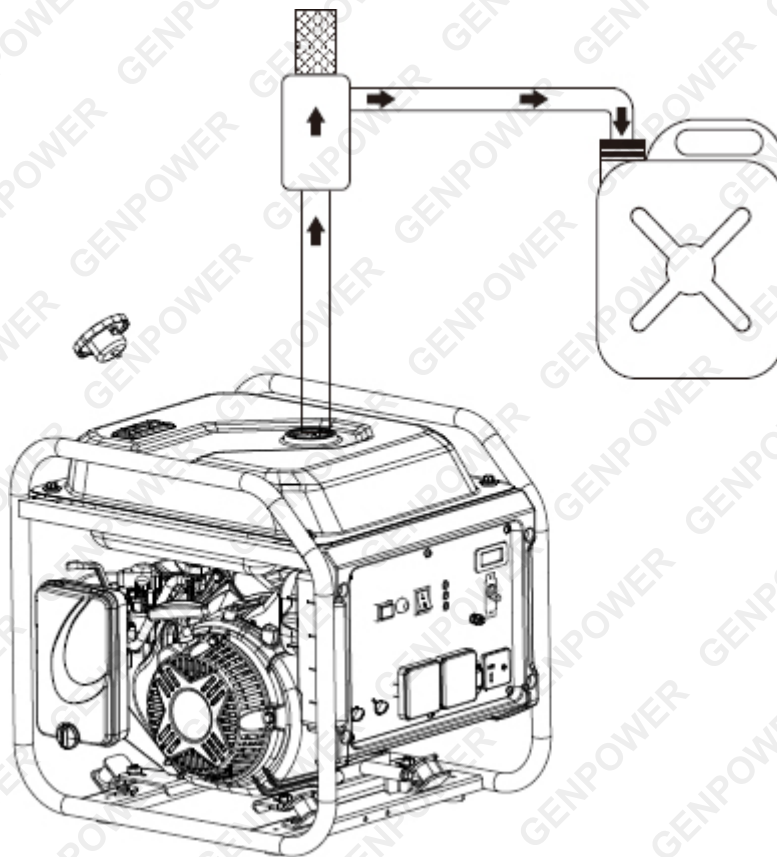

WARNING! Fuel is highly volatile and toxic. Please read the safety instructions carefully.

Notice! Wipe up any spilled fuel promptly using a clean, soft cloth to prevent damage to the plastic cover.

3. Start the generator and let it run until it automatically stops when all the fuel is used up.

Note: Do not connect any electrical equipment during this process. The running time depends on the remaining fuel in the tank.

4. Remove the spark plug, pour a small spoonful of SAE 10W30 oil into the cylinder, replace the spark plug, and rotate the engine to distribute the oil for lubrication.

GP3600i Inverter Generator

5. Pull the starter rope until resistance is felt.
6. Wipe down the surface of the unit and store it in a well-ventilated, dry place. Cover the generator with a protective cover.

Troubleshooting

1. Fuel System

- Problem: There is no gasoline in the fuel chamber.
- Possible Causes and Solutions:
 - No fuel in the tank: Refuel the tank.
 - Fuel filter blocked: Clean the fuel filter.
 - Carburettor blocked: Clean the carburettor.

2. Engine Oil System

- Problem: Oil level is too low.
- Solution: Add oil to the appropriate level.

3. Electrical System

- Problem: The generator does not start, or the spark plug does not ignite.
- Possible Causes and Solutions:
 - Ensure the fuel switch knob is in the "Run" position.
 - Pull the starter normally. If there is no ignition:
 - Spark plug carbon deposit or wet: Clean and dry the spark plug.
 - If the ignition system problem persists, please contact the designated dealer.

Specifications

Power Type	Petrol
Peak Output	3.6 kW
Continuous Rated Output	3.2 kW
Fuel Capacity	11 L
Oil Capacity	0.6 L
Engine Displacement	212 cc
Engine Output	6 hp / 3600 rpm
Engine Oil Type	SAE 10W-30
Runtime	50% Load: 9 hrs
Noise Level	50% Load: 70 dB, 100% Load: 74.5 dB
Starting System	Recoil
Power Outlets	2 x 15A Australian sockets
USB Outlets	2 x 5V 3.1A
DC Output	1 x 12V DC outlet
Warranty (Months)	36 (based on typical non-commercial use)



Some experts believe that the incorrect or prolonged use of almost any product may cause serious injury or death. To help reduce your risk of serious injury or death, refer to the information below. For more information, see www.datastreamserver.com/safety

- Consult all documentation, packaging, and product labelling before use. Note that some products feature documentation available online. It is recommended to print and retain the documentation.
- Before each use, check the product for loose/broken/damaged/missing parts, wear, or leaks (if applicable). Never use a product with loose/broken/damaged/missing parts, wear, or leaks.
- Products must be inspected and serviced (if applicable) by a qualified technician every 6 months. This is based on average residential use by persons of average size and strength, and on a property of average metropolitan size. Use beyond these recommendations may require more frequent inspections/servicing.
- Ensure that all users of the product have completed a suitable industry recognised training course before being allowed access to the product.
- The product has been supplied by a general merchandise retailer that may not be familiar with your specific application or description of application. Be sure to attain third-party approval from a qualified specialist for your application before use, regardless of any assurances from the retailer or its representatives.
- This product is not intended for use where fail-safe operation is required. As with any product (for example, automobile, computer, toaster), there is the possibility of technical issues that may require the repair or replacement of parts, or the product itself. If the possibility of such failure and the associated time it may take to rectify could in any way inconvenience the user, business, or employee, or financially affect the user, business, or employee, then the product is not suitable for your requirements. This product is not intended for use where incorrect operation or a failure of any kind, including but not limited to, a condition requiring product return, replacement, parts replacement, or service by a technician may cause financial loss, loss of employee time or an inconvenience requiring compensation.
- If this product has been purchased in error when considering the information presented here, contact the retailer directly for details of their returns policy, if required.

