

Bäumr-AG®

BPR-1100E

MATERIAL HANDLING DUMP CART



User Manual

[Revision 1.0]

THE BATTERY MAY HAVE SOME CHARGE ON ARRIVAL, IT IS IMPORTANT HOWEVER THAT THE BATTERY IS CHARGED PRIOR TO USE.

READ THIS MANUAL CAREFULLY BEFORE USE – FAILURE TO DO SO MAY RESULT IN INJURY, PROPERTY DAMAGE AND MAY VOID WARRANTY. • KEEP THIS MANUAL FOR FUTURE REFERENCE. • Products covered by this manual may vary in appearance, assembly, inclusions, specifications, description, and packaging.

Safety

Safety messages are designed to alert you to possible dangers or hazards that could cause death, injury or equipment or property damage if not understood or followed. Safety messages have the following symbols:



You **WILL** be **KILLED** or **SERIOUSLY INJURED** if you do not follow instructions.



You **CAN** be **KILLED** or **SERIOUSLY INJURED** if you do not follow instructions.



You **CAN** be **INJURED** if you do not follow instructions or equipment damage may occur.

It is vital that you read and understand this user manual before using the product, including safety warnings, and any assembly and operating instructions. Keep the manual for future reference.

Safety precautions and recommendations detailed here must be fully understood and followed to reduce the risk of injury, fire, explosion, electrical hazard, and/or property damage.

Safety information presented here is generic in nature – some advice may not be applicable to every product. The term "equipment" refers to the product, be it electrical mains powered, battery powered or combustion engine powered.

- **Before Use** - If you are not familiar with the safe operation/handling of the equipment or are in any way unsure of any aspect of suitability or correct use for your application, you should complete training conducted by a person or organization qualified in safe use and operation of this equipment, including fuel/electrical handling and safety.
- Do NOT operate the equipment in flammable or explosive environments, such as in the presence of flammable liquids, gases, or dust. The equipment may create sparks or heat that may ignite flammable substances.
- Keep clear of moving parts.
- Equipment may be a potential source of electric shock or injury if misused.
- Do NOT operate the equipment if it is damaged, malfunctioning or is in an excessively worn state.
- Do NOT allow others to use the equipment unless they have read this manual and are adequately trained.
- Keep packaging away from children - risk of suffocation! Operators must use the equipment correctly. When using the equipment, consider conditions and pay due care to persons and property.

General Work Area Safety

- Work areas should be clean and well lit.
- Do not operate the equipment if bystanders, animals etc are within operating range of the equipment or the general work area.
- If devices are provided for connecting dust extraction / collection facilities, ensure these are connected and used properly. Dust collection can reduce dust-related hazards.

General Personal Safety

- Wear appropriate protective equipment when operating, servicing, or when in the operating area of the equipment to help protect from eye and ear injury, poisoning, burns, cutting and crush injuries. Protective equipment such as safety goggles, respirators, non-slip safety footwear, hard hat, hearing protection etc should be used for appropriate equipment / conditions. Other people nearby should also wear appropriate personal protective equipment. Do not wear loose clothing or jewellery, which can be caught in moving parts. Keep hair and clothing away from the equipment.
- Stay alert and use common sense when operating the equipment. Do not over-reach. Always maintain secure footing and balance.
- Do not use the equipment if tired or under the influence of drugs, alcohol, or medication.
- This equipment is not intended for use by persons with reduced physical, sensory, or mental capabilities.

General Fuel Safety

- Petrol/fuel/gasoline is extremely flammable – keep clear of naked flames or other ignition sources.
- Do not spill fuel. If you spill fuel, wipe it off the equipment immediately – if fuel gets on your clothing, change clothing.
- Do NOT smoke near fuel or when refuelling.
- Always shut off the engine before refuelling.
- Do NOT refuel a hot engine.
- Open the fuel cap carefully to allow any pressure build-up in the tank to release slowly.
- Always refuel in well-ventilated areas.
- Always check for fuel leakage. If fuel leakage is found, do not start, or run the engine until all leaks are fixed.

General Carbon-Monoxide Safety

- Using a combustion engine indoors **CAN KILL IN MINUTES**. Engine exhaust contains carbon-monoxide – a poison you cannot smell or see.
- Use combustion engines **OUTSIDE** only, and far away from windows, doors, and vents.

General Equipment Use and Care

- Keep packaging away from children and pets, potential risk of suffocation or choking.
- The equipment is designed for domestic use only.
- Handle the equipment safely and carefully.
- Before use, inspect the equipment for misalignment or binding of moving parts, loose components, damage, or any other condition that may affect its operation. If damaged, have the equipment repaired by an authorised service centre or technician before use.
- Prevent unintentional starting of the equipment - ensure equipment and power switches are in the OFF position before connecting or moving equipment. Do not carry equipment with hands or fingers touching any controls. Remove any tools or other items that are not a part of the equipment from it before starting or switching on.
- Do not force the equipment. Use the correct equipment for your application. Equipment will perform better and be safer when used within its design and usage parameters.
- Use the equipment and accessories etc. in accordance with these instructions, considering working conditions and the work to be performed. Using the equipment for operations different from those intended could result in hazardous situations.
- Always keep equipment components (engines, hoses, handles, controls, frames, housings, guards etc) and accessories (cutting tools, nozzles, bits etc) properly maintained. Keep the equipment clean and, where applicable, properly lubricated.
- Store the equipment out of reach of children or untrained persons. To avoid burns or fire hazards, let the equipment cool completely before transporting or storing. Never place or store the equipment near flammable materials, combustible gases, or liquids etc.
- The equipment is not weather-proof, and should not be stored in direct sunlight, at high ambient temperatures or locations that are damp or humid.
- Do not clean equipment with solvents, flammable liquids, or harsh abrasives.
- For specific equipment safety use and care, see Equipment Safety.

General Electrical Safety

- Inspect electrical equipment, extension cords, power bars, and electrical fittings for damage or wear before each use. Repair or replace damaged equipment immediately.
- Ensure all power sources conform to equipment voltage requirements and are disconnected before connecting or disconnecting equipment.
- When wiring electrically powered equipment, follow all electrical and safety codes.
- Always use a Residual Current Device (RCD) (GFCI) / Earth Leakage Circuit Breaker / Safety Switch when operating this item (electrical items only).
- High voltage / high current power lines may be present. Use extreme caution to avoid contact or interference with power lines. Electrical shock can be fatal.

General Electrical Safety

- Electrically grounded equipment must have an approved cord and plug and be connected to a grounded electrical outlet.
- Do NOT bypass the ON/OFF switch and operate equipment by connecting and disconnecting the electrical cord.
- Do NOT use equipment that has exposed wiring, damaged switches, covers or guards.
- Do NOT use electrical equipment in wet conditions or in damp locations.
- Do NOT use electrical cords to lift, move or carry equipment.
- Do NOT coil or knot electrical cords, and ensure electrical cords are not trip hazards.

General Service Information

- The equipment must be serviced or repaired at authorised service centres by qualified personnel only.
- Replacement parts must be original equipment manufacturer (OEM) to ensure equipment safety is maintained.
- Do NOT attempt any maintenance or repair work not described in this manual.
- After use, the equipment and components may still be hot – allow the equipment to cool and disconnect spark plugs and/or electrical power sources and/or batteries from it before adjusting, changing accessories, or performing repair or maintenance.
- Do NOT adjust while the equipment is running.
- Perform service-related activities in suitable conditions, such as a workshop.
- Replace worn, damaged or missing warning/safety labels immediately.

Child Choking Hazard!



• **WARNING: CHOKING HAZARD - CHILDREN UNDER 8 YRS. CAN CHOKE OR SUFFOCATE ON SMALL PARTS. ADULT SUPERVISION REQUIRED.**

- Carefully inspect anything a baby or child could gain access to, including this product & packaging.
- Dangers include anything of a size that could become stuck or lodged in a baby or child's airway.
- Dangers include things like raw, hard fruit and vegetable pieces, large pieces of meat, bones or sausage skins, popcorn, nuts, hard lollies and corn chips, small magnets and batteries, coins, beads, marbles and small uninflated balloons, broken toys and smaller toys, buttons, keys, and coins. But there are also many more.
- Pay particular attention to accessories, nuts, bolts, screws, washers, caps, covers, loose parts, parts that could be removed or break off, pieces of packaging, staples, tape etc.
- In the case of any doubt, secure the item of concern in an appropriate manner, or completely remove the possibility of access by a baby or child.

Intended Use

- The machine must only be used for its intended purpose. Any other use is considered misuse.
- To operate the machine correctly, you must observe and follow all safety regulations, as well as the assembly, operating, and maintenance instructions provided in this manual.
- All users must be familiar with this manual and aware of the machine's potential hazards.
- Intended purpose: Transporting goods within the maximum permissible load capacity.
- Any modification or manipulation of the machine or its components is considered misuse. In such cases, the manufacturer cannot be held liable for any direct or indirect damage.
- **⚠ WARNING: REMOVING OR MODIFYING SAFETY COMPONENTS MAY CAUSE SERIOUS INJURY OR DAMAGE TO THE MACHINE. HIGHEST RISK OF INJURY!**

Ambient Conditions

- The machine should be operated under the following conditions:
 - Humidity: 0% to 70%
 - Temperature: 0 °C to 40 °C
- **⚠** Do not expose the machine or its battery to temperatures exceeding 40 °C. Avoid prolonged exposure to direct sunlight or confined spaces, such as the boot of a vehicle.
- Prohibited Use:
 - Operating the machine outside the technical limits specified in this manual.
 - Operating without the required protective devices.
 - Using the machine for purposes not described in this manual.
 - Tampering with or modifying the machine or its components.

Safety Instructions

- **⚠** Missing or unreadable safety labels must be replaced immediately.
- Local laws and regulations may specify the minimum operator age and restrict machine use.
- To prevent malfunctions, damage, or injury, observe the following safety guidelines:

General

- Operate the machine only in adequate lighting to ensure safe visibility.
- Do not operate the machine when tired, distracted, or under the influence of alcohol, drugs, or medication.
- Be cautious on slippery surfaces. Wear sturdy, non-slip footwear.
- The machine must only be operated by trained and authorised personnel.
- Always use both hands when operating the machine.
- Keep this manual with the machine and provide it to the new owner if transferred.
- Inspect the machine for damage or faults before each use.
- Use caution when operating near water (e.g., pools, ponds, or wet areas).
- Do not operate the machine in rain or damp conditions.
- Disconnect the battery before performing maintenance or making adjustments.

Charger Safety

- Use the charger only for this machine's battery. Charging other batteries is prohibited.
- Do not use the charger in wet or humid conditions.
- Disconnect the charger by pulling the plug, not the cable, to prevent damage.
- Do not use the charger if the cable, plug, or housing is damaged.
- Keep the charger away from heat sources.
- Do not use an extension cord to power the charger.
- Keep metal objects away from the charging contacts.
- Do not open the charger. In case of malfunction, contact a qualified technician.
- Only use the original charger supplied with the machine. Using other chargers may cause damage or fire hazards.

Battery Safety

- Improper or damaged batteries may emit harmful vapours. Move to fresh air and seek medical attention if symptoms occur.
- **⚠ FIRE HAZARD: NEVER CHARGE BATTERIES NEAR ACIDS OR FLAMMABLE MATERIALS.**
- Charge only at ambient temperatures between 0 °C and 40 °C. Allow the battery to cool after use before recharging.
- **⚠ EXPLOSION RISK: KEEP THE BATTERY AWAY FROM HEAT AND OPEN FLAMES.**
- Use the battery only at ambient temperatures between 0 °C and 40 °C.
- **⚠ SHORT CIRCUIT RISK: DURING STORAGE, TRANSPORT, OR DISPOSAL, COVER BATTERY TERMINALS WITH TAPE OR PLACE THE BATTERY IN A PROTECTIVE BAG.**
- Never open or dismantle the battery.

Residual Risks





















- Even when used correctly, some residual risks remain due to the machine's design. These are identified in this manual as follows:
 - **DANGER:** Indicates an imminent hazard that will result in death or serious injury if not avoided.
 - **WARNING:** Indicates a potential hazard that may result in serious injury or death if not avoided.
 - **CAUTION:** Indicates a potential hazard that may result in minor or moderate injury if not avoided.
 - **NOTICE:** Indicates a situation that may result in property damage if not avoided.

Safe Operation Reminder

- Regardless of all safety instructions, your awareness, common sense, and technical skill remain the most important factors in ensuring safe and error-free operation. Safe work depends primarily on you.

Safety Symbols

The product may have safety warning labels attached to it, explained below. Understand the symbols on your product and their meanings. If any stickers become unreadable, unattached etc., replace them.

 <p>Flammable Material Hazard Flammable liquids, gases, or substances etc may present. Avoid ignition sources and open flames. Danger of fire.</p>	 <p>Read User Manual Read and fully understand product safety warnings, operation, procedures etc before using the product.</p>	 <p>Use Hand Protection Wear appropriate hand protection and take due care as the product or use of the product may present hand hazards.</p>	 <p>Carbon-Monoxide Hazard Do not use the product in confined areas or without adequate ventilation. Carbon-monoxide poisoning can be fatal.</p>
 <p>Electrocution / Electrical Shock Hazard High voltage or high current electricity may be present or required by the product. Take due care when handling electrical products, cables, plugs and leads. Electrical shock can be fatal.</p>	 <p>Toxic Fumes / Dust Hazard Using the product or by-products from use may produce fumes, smoke or particles that could be harmful if inhaled. Wear appropriate breathing protection and have adequate ventilation.</p>	 <p>Explosive Material Hazard Combustible liquids, gases, or substances etc may be present. Avoid ignition sources and open flames. Danger of explosion.</p>	 <p>Cutting / Amputation Hazard The product may have blades, edges or mechanical devices that can cause severe cut injury to fingers, limbs etc. Take due care when handling and using the product.</p>
 <p>Crush Hazard The product may have blades, edges or mechanical devices that can cause severe crush injury to fingers, limbs etc. Take due care when handling and using the product.</p>	 <p>Single Operator Only The product must be operated by a single person only. More than one person operating the product may introduce additional hazards.</p>	 <p>Use Face Protection Wear appropriate full-face protection and take due care as the product or use of the product may present face and eye hazards.</p>	 <p>Use Foot Protection Wear appropriate foot protection and take due care as the product or use of the product may present foot hazards.</p>
 <p>Use Eye / Ear / Head Protection Wear appropriate eye and / or ear and / or head protection and take due care as the product or use of the product may present eye, hearing, and head hazards.</p>	 <p>Running Hazard Do not run on or near the product as doing so may present a fall hazard.</p>	 <p>Diving Hazard Do not dive into the product as doing so may present a neck / head injury hazard.</p>	 <p>Adult Supervision Required Always supervise children and other users of a product to prevent drowning or injury.</p>
 <p>Skin Penetration / Puncture Hazard The product may produce pressure, emit liquids or objects that can cause severe injury to fingers, limbs, blood etc. Take due care when handling and using the product.</p>	 <p>Hot Surface Hazard Be aware that the product may produce high temperatures and hot surfaces that can cause burn injuries.</p>	 <p>Flying Debris Hazard Be aware that the product or use of the product may present hazards produced by flying debris. Wear appropriate clothing and protective devices.</p>	 <p>Moving Parts Hazard Be aware that the product contains or uses mechanical devices that move or rotate. Always wait for moving parts to stop fully before handling the product, adjusting, maintenance etc.</p>















 <p>Carbon-Monoxide Hazard Do not use the product in confined areas or without adequate ventilation. Carbon-monoxide poisoning can be fatal.</p>	 <p>Pull Hazard Be aware that the product contains or uses mechanical devices that can pull in objects and can cause severe injury to fingers, limbs etc. Take due care when handling and using the product.</p>	 <p>Slope / Fall Injury Hazard Be aware that using the product on sloping surfaces or in slippery conditions may present additional dangers from falls and contact with blades, moving parts, hot surfaces etc.</p>	 <p>"Slam Dunk" Warning Do NOT attempt "slam dunk" manoeuvres as this may result in severe injury due to falling, product breakage or collapse etc.</p>
 <p>Electrocution / Electrical Shock Hazard - Outdoor High voltage or high current electricity may be present or required by the product. Do NOT use in rain, damp, or wet conditions. Electrical shock can be fatal.</p>	 <p>Electrocution / Electrical Shock Hazard - Disconnect High voltage or high current electricity may be present or required by the product. Always disconnect the product from the electrical supply before handling the product, adjusting, maintenance etc.</p>	 <p>Power Line Electrocution Hazard High voltage / high current power lines may be present. Use extreme caution to avoid contact or interference with power lines. Electrical shock can be fatal.</p>	 <p>"Kick-Back" Hazard High level of "kick-back" hazard that can cause the machine to suddenly rotate towards operator. Kick-back injury can be fatal.</p>
 <p>Winch Operator Position Hazard Do NOT stand between winch and load. Do NOT use winch to move people.</p>	 <p>Winch Lift Hazard Do NOT LIFT load vertically. Use machine to PULL only.</p>	 <p>Cable Hazard Ensure that load bearing cable is not kinked or knotted.</p>	 <p>Winch Cable Hazard Ensure that there is a minimum number of cable coils on winching mechanism.</p>
 <p>Winch Hook Hazard Carry hook to load – do NOT throw or run.</p>	 <p>Flash / Blinding Hazard Wear appropriate eye protection for welding. Direct exposure to weld arcs may cause permanent eye injury.</p>	 <p>Laser Hazard Laser may be in use – do NOT look directly at laser or allow others to.</p>	 <p>Choking Hazard Children under 8 yrs. Can choke or suffocate on small parts. Adult supervision required.</p>

Table of Contents

Safety	2
Safety Symbols	5
Parts Identification	8
Main Components	8
Exploded Diagram	9
Assembly	10
Assembly – Body	10
Assembly – Cable Connection	14
Operation	15
Starting Electrical Support	15
Control Operation	16
Electronic Brake System (EBS) and Brake Assist System (BAS)	16
Charger	17
Lithium Battery Care and Maintenance	18
Top 3 Battery Care Requirements	18
Maintenance	20
Maintenance Plan	20
Cleaning	20
Storage	20
Disposal	21
Troubleshooting	21
Specifications	22

Parts Identification

Main Components



No.	Name
1	U Support
2	Battery Box Assembly
3	Front Tyre
4	Battery Box
5	Tray

Exploded Diagram

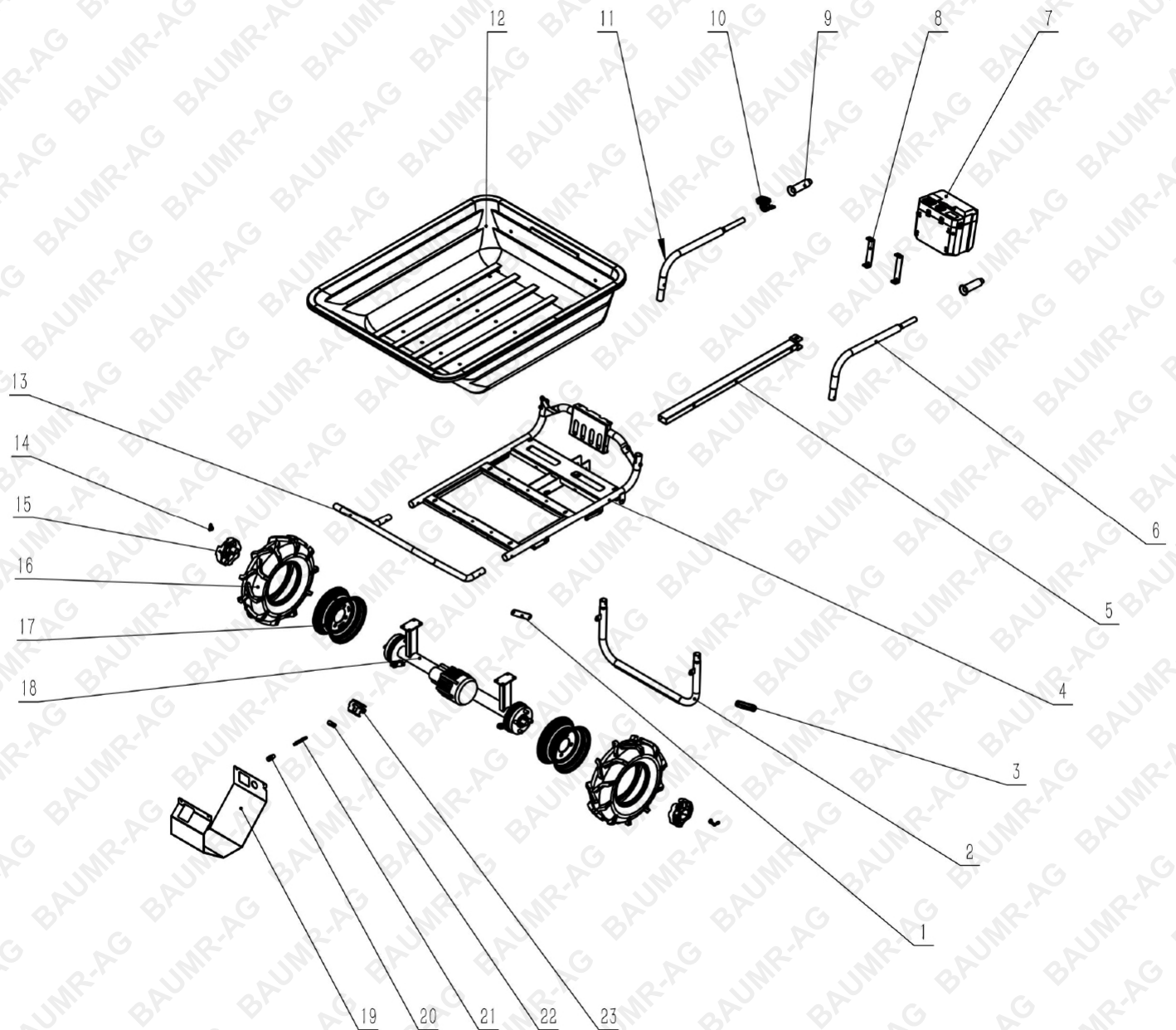

No.	Part Name	Qty	No.	Part Name	Qty
1	Right Locking Bar	1	13	Front Tray Support	1
2	U Support	1	14	PVR60 Vacuum Tyre	2
3	Left Locking Bar	1	15	Hub Cover	2
4	Base Frame	1	16	Front Tyre	2
5	ATV Bar	1	17	Rim	2
6	Left Handle	1	18	Motor Assembly	1
7	Battery Box Assembly	1	19	Motor Cover	1
8	Connection Board	2	20	Bakelite Ball Handle	1
9	Handle Grip	2	21	Neutral Lever	1
10	Speed Control Lever	1	22	Gear Shift	1
11	Right Handle	1	23	Gear Shift Cable	1
12	Tray	1			

Assembly



Inspect the product immediately upon receipt for any transport damage or missing parts. Claims for transport damage or missing parts must be made immediately after unpacking and before operating the machine. Later claims cannot be accepted.

Notice: Do not fully tighten screws until assembly is complete.

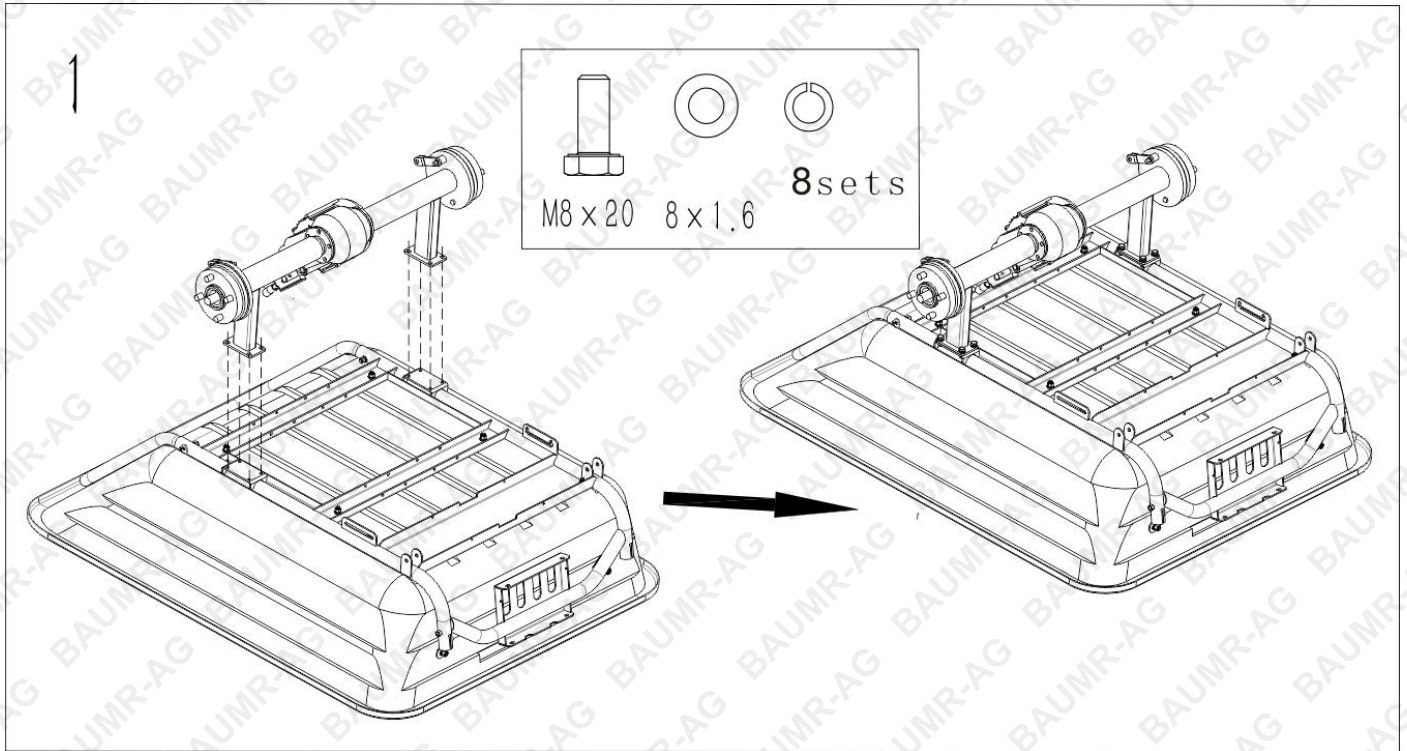
Assembly – Body





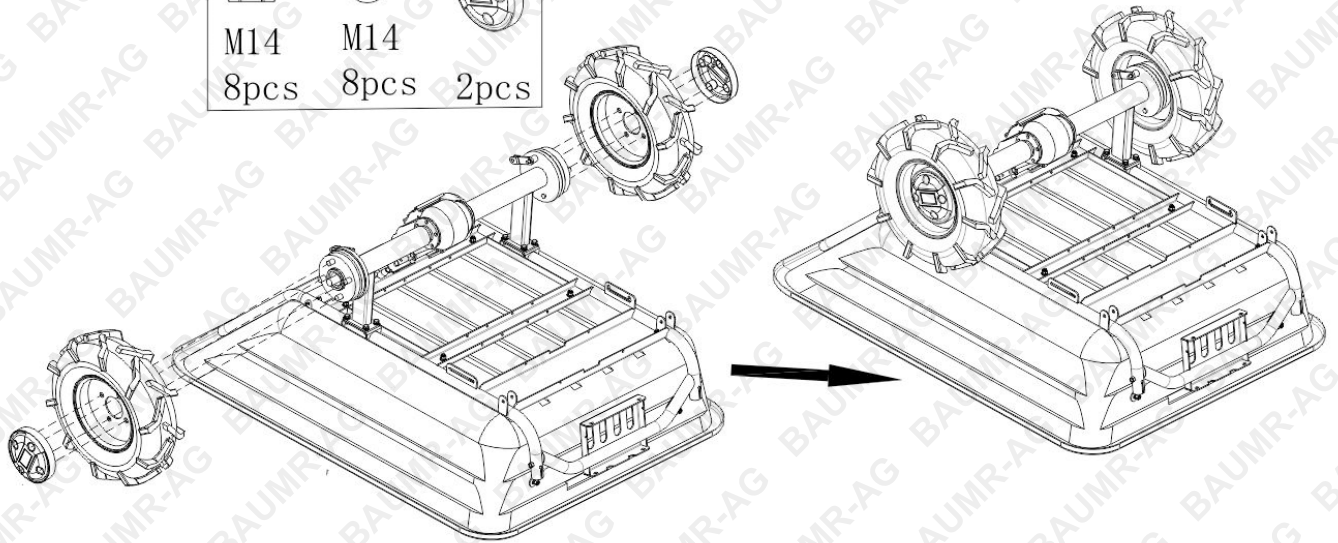

2

		
M14	M14	
8pcs	8pcs	2pcs



3

			
M8 x 50	M8 x 25	8 x 1.6	M8
2pcs	4pcs	8pcs	6pcs

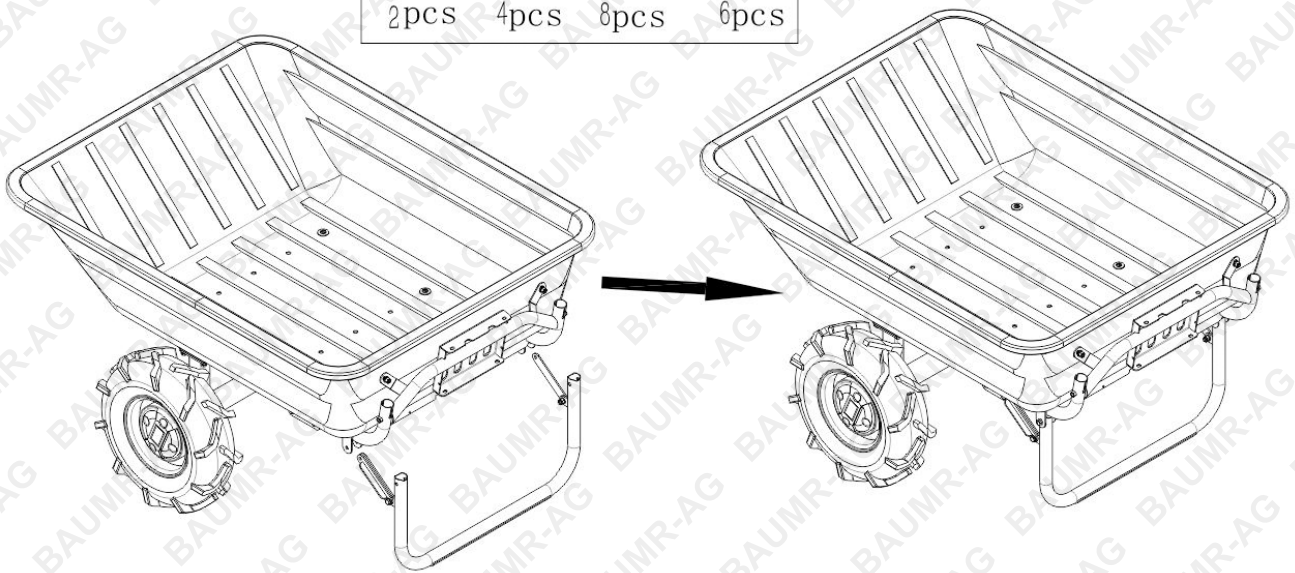

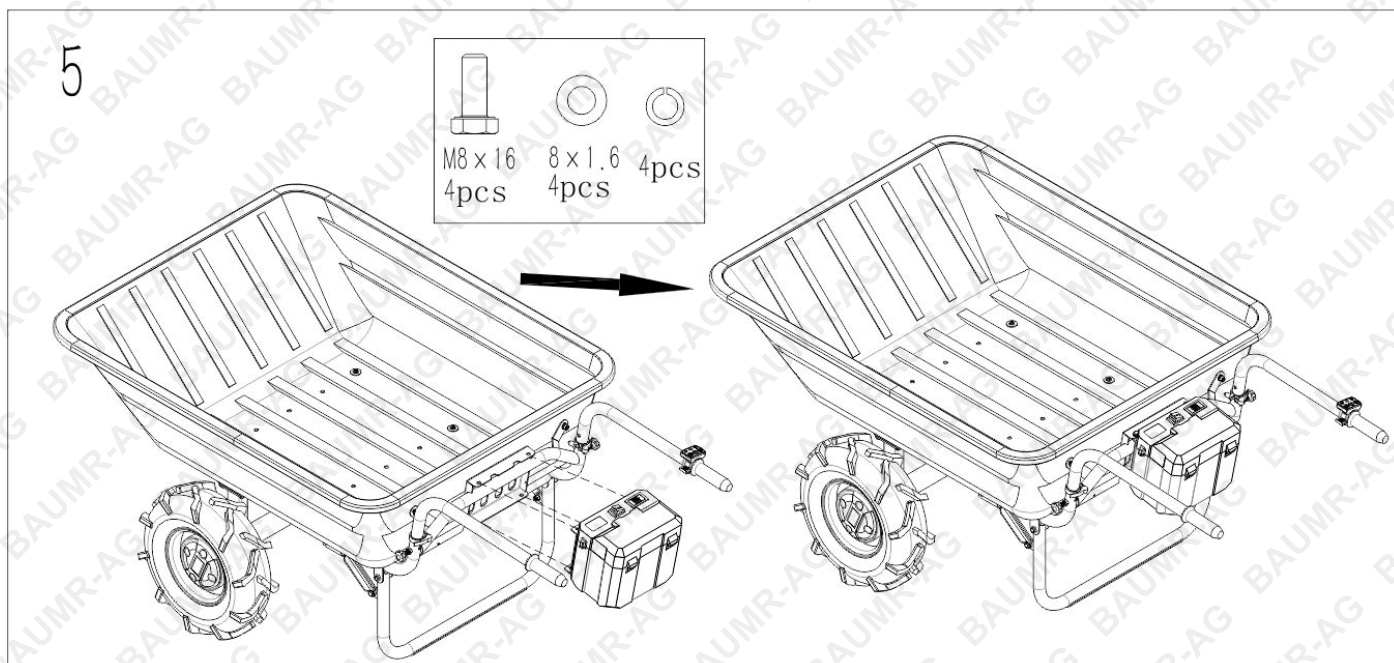
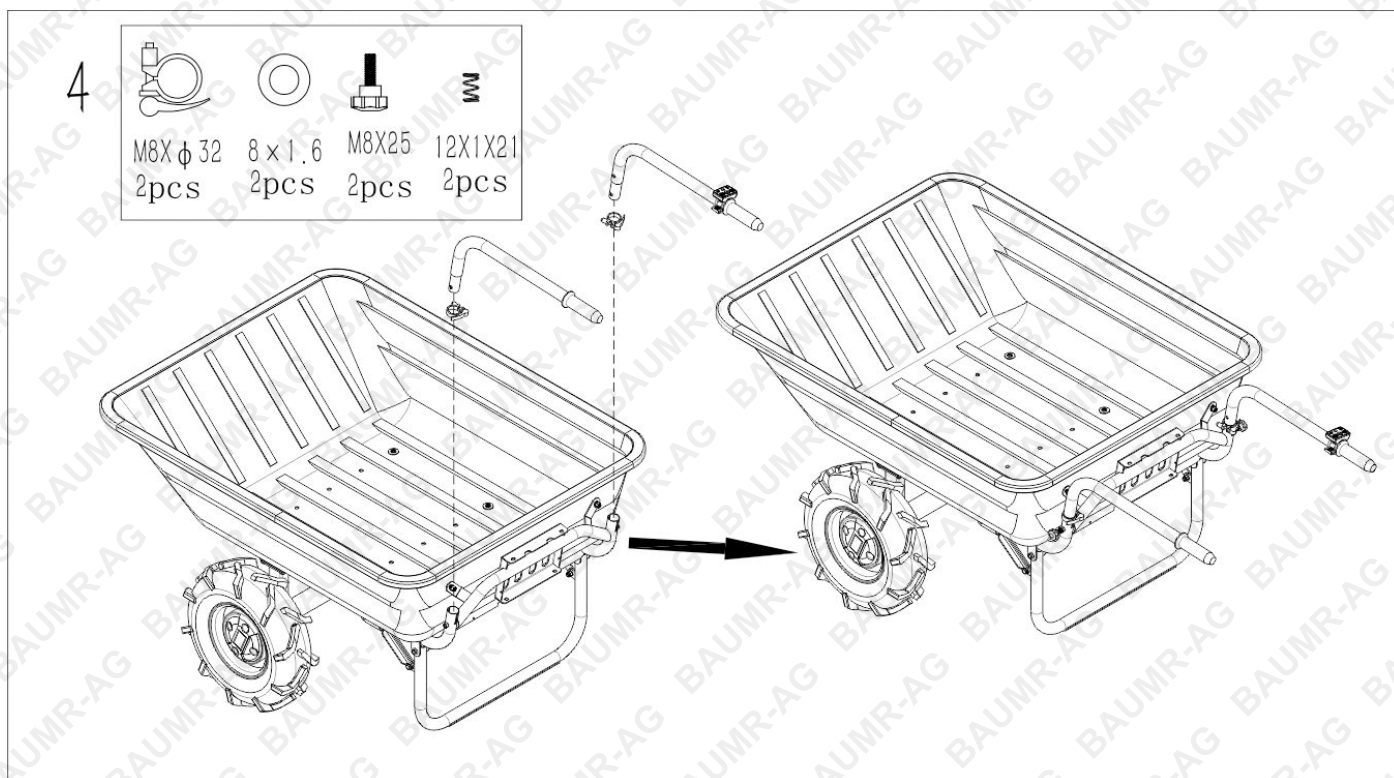

Installing the Speed Control Lever

When installing, ensure the speed control lever is correctly positioned on the right handle.

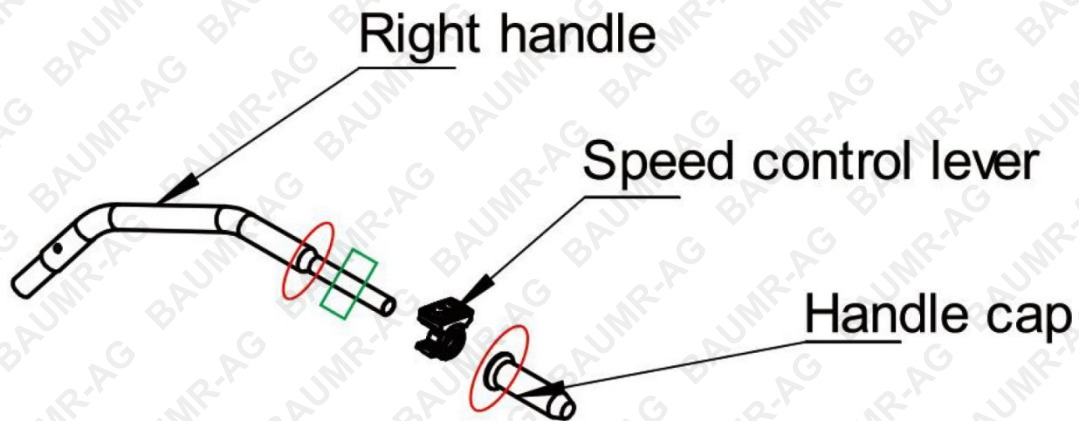

- Avoid positioning it on the **red**-marked area.
- Fix the speed control lever on the flat section of the handle (**green range**).
- Do not place it too close to the handle cap.

Battery Installation and Position Check

Ensure the battery is correctly positioned before use.

Not in position

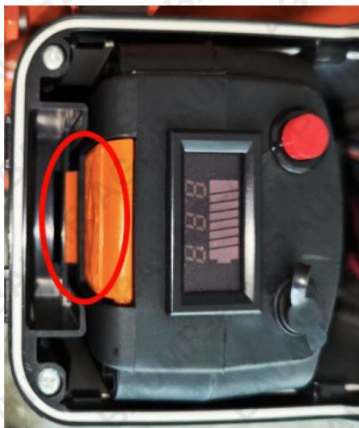

Poor contact – the buckle clip is visible and not fully engaged.

Correct Position



Correct contact – the buckle clip is covered and no longer visible.

Correct Way to Insert the Battery

1. Hold the battery securely.
2. Press the centre of the buckle.
3. Slide the battery into the compartment until it locks into place.



✓ The battery is properly installed when it fits flush and the buckle clip is no longer visible.

Assembly – Cable Connection

Connect the cable as shown in the diagram.



- 3-pin connector → Battery box
- 5-pin connector → Battery box
- 10-pin connector → Control handle

⚠ WARNING! Only Nut #1 may be turned to fasten or unfasten the plug. Nut #2 must not be turned — doing so may damage the cable and will require professional repair.



Operation

The machine must only be operated when it is in perfect working condition. Visually inspect the machine before each use. Check the safety equipment, electrical controls, cables, and all screwed connections to ensure they are secure and undamaged. Replace any damaged parts before operating the machine.

⚠ WARNING! Always unplug the battery before performing any maintenance or adjustments.

NOTICE: Never remove the battery while the machine is running. For extended periods of non-use, press the shut-down button. Operate the electric motor only when the battery is adequately charged.

Starting Electrical Support

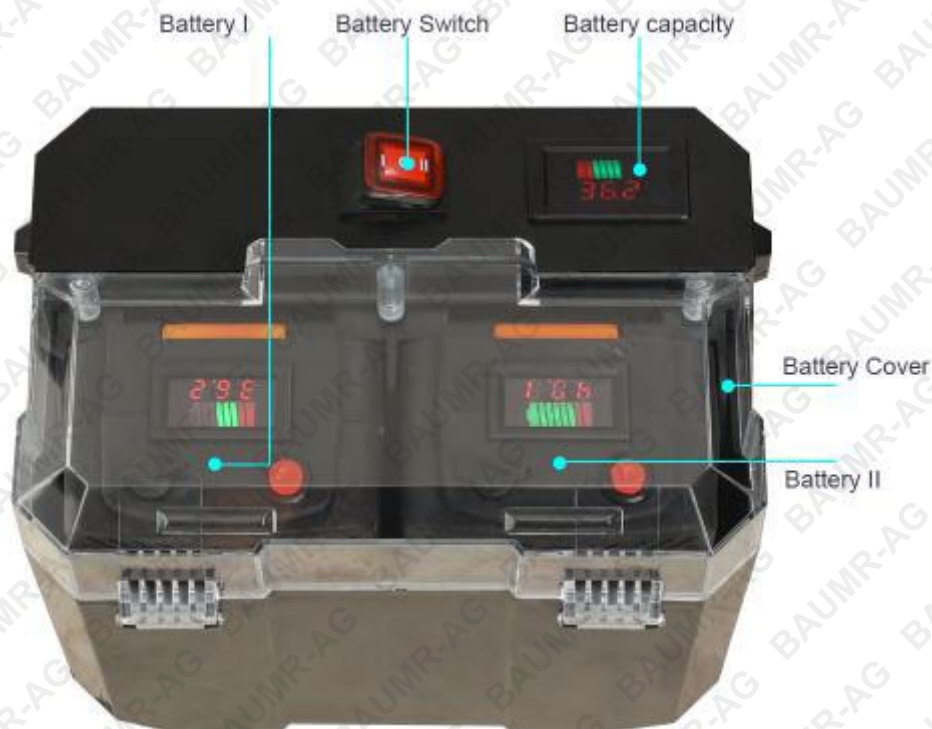

1. Press the button on the battery box to I = ON – the left battery will supply power; the right battery will remain inactive.
2. Press the button on the battery box to II = ON – the right battery will supply power; the left battery will remain inactive.

Note: Each wheelbarrow is supplied with one battery as standard.

Control Operation



Lights:

- L4 (green), L3 (green), and L1 (green) – ON
- L2 and L5 – OFF

Throttle Operation:

- Press Throttle Lever #1 – Wheelbarrow moves forward.
- Press Button #2 – L4 and L5 lights turn ON. Then press Throttle Lever #1 – Wheelbarrow moves backward.
- Press Button #3 – L3 light turns red, activating the Electronic Brake System (EBS). The wheelbarrow will not move even if Throttle Lever #1 is pressed.
- Press Button #3 again – EBS deactivates.
- Press Button #4 – L2 light turns ON, activating Power Mode for increased torque.
- Press Button #4 again – Returns to Eco Mode for extended runtime.

Electronic Brake System (EBS) and Brake Assist System (BAS)

This wheelbarrow is equipped with Electronic Brake System (EBS) and Brake Assist System (BAS) for enhanced control and safety.

BAS (Brake Assist System)

The BAS operates when:

- The power button on the battery box is set to I = ON.
- The Throttle Lever #1 is in its original (idle) position.

EBS (Electronic Brake System)

The EBS operates when:

- The power button on the battery box is set to I = ON.
- The Brake Switch #3 is in the “1” position.

Notes:

- When EBS is ON, the wheelbarrow will come to a complete stop. The throttle lever will not function.
- When BAS is ON, the wheelbarrow remains stationary on level ground but may move slowly on a downward slope.
- BAS does not affect battery power, while EBS does. It is recommended to use BAS for regular operation.
- Both systems enhance safety, especially when operating on slopes or when dumping loads.

Charger

The charger is integrated into the battery system.

Charging the Battery

1. Connect the charger to an AC power outlet (230 V / 50 Hz) and plug it into the charging port.
2. Allow the battery to charge fully.
3. Once fully charged (as indicated on the charger), disconnect the charger.

LED Indicator – Battery Box Display

The voltage display on the battery box shows the battery's charge level:

Voltage Display	Battery Capacity
42 V	100%
35 V	~50%
< 30 V	Recharge required





Battery Components:

1. Voltage Display Switch
2. Voltage Display Screen
3. Recharge Port

Lithium Battery Care and Maintenance

Top 3 Battery Care Requirements

1. **Charge battery before first use.** The battery may arrive with some charge, regardless of this the battery must be charged for 3.8 hours on the initial charge and 3.8 hours for each subsequent charge. 
2. **Charge battery immediately when it is depleted.** Do not store a depleted battery. This will permanently impact the life of the battery. If the battery is going to be stored for a period of time, fully charge the battery before storing. 
3. **Disconnect battery when not in use.** To prolong the life of a battery, disconnect it from the unit when not in use. Disconnect chargers from the battery once charged. 

To ensure the battery maintains optimum performance, follow the guidelines outlined below.

- For best results, charge batteries in temperatures between 10°C and 30°C
- When battery is charged, disconnect the charger from the power supply and remove the battery from the charger.
- If a battery is stored or otherwise unused for an extended period, and the battery has no charge remaining when you check it, consider it to be damaged. Do not attempt to recharge it or to use it. Replace it with a new battery.
- Use only with the battery charger specified by the manufacturer.
- Ensure that the battery charger electrical cord is not subjected to damage or stress. Do not operate the battery charger if it has a damaged electrical cord or plug.
- Do not use the charger in wet areas or expose it to rain or water.
- The typical estimated life of a Lithium-Ion battery is about two to three years or 300 to 500 charge cycles, whichever occurs first. One charge cycle is a period of use from fully charged, to fully discharged, and fully recharged again.
- Explosion hazard – protect the battery against heat, for example, direct sunlight and fire. Do not store batteries in vehicles or locations subject to heat.
- Batteries can explode in the presence of an ignition source, such as a pilot light. To reduce the risk of serious personal injury, never use any cordless product in the presence of open flame. Exploding batteries can propel debris and chemicals.
- Do not open the battery – danger of short-circuiting and/or explosion.
- Do not attempt to destroy or disassemble the battery pack or remove any of its components.
- Do not touch the battery terminals with metal objects and/or body parts as short-circuit and/or personal injury may result.
- Explosion hazard – do not open and/or short-circuit the battery.
- Poison hazard – battery leakage (liquid ejection). Under extreme conditions, liquid may be ejected from the battery – avoid contact. If contact accidentally occurs, immediately seek medical attention, and flush with water. If liquid contacts eyes, immediately seek medical attention, flush with clean water for at least 10 minutes. Liquid ejected from the battery may cause irritation or burns.
- Dispose of non-serviceable batteries in an environmentally responsible manner and according to local regulations.

Failure to adhere to the requirements above may result in the battery becoming inoperative or battery life being reduced. In extreme cases or abuse, battery overheating, or fire may result.

DANGER - BATTERY CHARGING, USE AND STORAGE

Like mobile phones, laptops, cordless vacuum cleaners etc, this product may contain or be related to a lithium ion battery pack (lithium ion batteries and lithium ion battery related items only). Lithium ion batteries allow fast charging and high capacities, however care must be taken to reduce chances of a fault, and increase safety in case a fault occurs. Catastrophic incidents involving lithium ion batteries have a tendency to result in large amounts of smoke and fire. Be sure to follow the points below to reduce the likelihood of danger whenever you use, charge or store any lithium ion battery.

- Never charge a battery that has been damaged or subjected to a forceful impact.
- Never charge a battery that has been exposed to moisture or water.
- Never charge a battery with a charger that wasn't supplied with the battery.
- Never use a battery in a device that it wasn't specifically designed for.
- Never use a battery with a modified or damaged device.
- Never modify the battery, product, charger, circuitry or wiring.
- Never charge a battery in an exit path that may be used by people to leave a room or building in case of an emergency, for example, the hallway or foyer of a residence.
- Never charge a battery in an area or building that doesn't have the recommended number of working smoke detectors that have been tested in accordance with local guidelines.
- Never charge a battery when the battery or charger is displaying a problem or charging incorrectly.
- Always charge batteries on a non-combustible surface, for example, on a concrete floor.
- Always charge batteries at least 3m away from anything combustible, such as floors, wall surfaces, furniture, storage shelves etc.
- Always charge batteries in an open area (outside if possible) ensuring the battery and charger are away from moisture and water.
- Always disconnect batteries from the charger after charging.
- Always remove or disconnect batteries from the device/product when not in use.
- Always ensure batteries are charged under adult supervision. Do not charge unattended. Do not charge batteries while no one is home or while people are sleeping.
- Keep batteries away from heat and moisture.
- Damaged batteries should be disposed of through your local e-waste collection service.
- Avoid mixing and matching chargers. Unplug products when fully charged, and charge batteries in a cool, dry place away from combustible materials like beds, lounges, or carpet.
- During charging and use, check your lithium-ion batteries for overheating, signs of swelling, leaking, or venting gas. Immediately stop using your product if these signs are present.
- Allow batteries to cool after use and before charging.

Maintenance

ATTENTION: Surface corrosion will occur on metal surfaces over time and the rate of oxidation depends on factors such as proximity to the ocean and humidity or condensation of water vapour on metal surfaces. To mitigate this, WD40 can be used to remove surface corrosion then, when applied periodically, it will prevent rust from forming.

ATTENTION: Always unplug the battery before performing any maintenance or adjustments. Serious injury may occur from unintentional or automatic activation of the machine. The machine requires minimal maintenance. If malfunctions or defects occur, servicing must only be carried out by trained personnel.

Notice

- Clean the machine regularly after every use – this extends its lifespan and ensures a safe working environment.
- Repairs must only be carried out by qualified professionals.
- Regularly check the condition of safety stickers and replace them if required. Also inspect the general condition of the machine.
- Store the machine in a closed, dry location.

Maintenance Plan

After each work shift, inspect cables for secure fit and damage.

Cleaning

Notice

- Do not use harsh chemicals, abrasive agents, or scrubbing tools, as they may damage the surface.
- Clean surfaces with a mild solution and a soft, damp cloth.
- Never use running water or a high-pressure cleaner.
- Never clean electronic components with water.

General cleaning:

- Wipe outer parts with a damp sponge.
- Remove debris or build-up with a soft brush.

Storage

- Thoroughly clean all components before storage.
- Store components in a dry location at temperatures above -10 °C.
- Fully charge the battery before storage.

🔔 Notice: During extended periods of non-use, recharge the battery at least once per month.

Disposal

- Do not dispose of the machine or battery with household waste.
- Contact your local authority for approved disposal options.

Troubleshooting

⚠ Before starting any troubleshooting, unplug the battery.

Issue	Possible Cause	Solution
No Electrical Support		
Battery capacity is low	Battery voltage too low	Check voltage with the display switch. Recharge or replace with another battery.
Speed control lever operated too fast	Buffer start delay	Wheelbarrow will begin moving about 1 second after pressing the speed regulator.
EBS is ON	Electronic Brake System activated	Switch off EBS on the speed control lever. For 2022 version: Press the "P" button until the light turns green.
Power switch damaged	Faulty switch	Replace the power switch.
Broken or loose cables	Cables not connected	Inspect, tighten, or replace cables.
Clutch disengaged	Clutch not in ON position	Push clutch to ON position.
Motor stuck	Motor jammed or faulty controller	1. Disconnect motor cable and attempt to rotate the motor manually. If it rotates freely, replace motor controller. 2. If still stuck, replace motor.
ECU in motor controller broken	ECU failed due to overload	Replace ECU. New ECU will prevent overload if used correctly.
Extra Resistance		
BAS is ON	Brake Assist System active	When power is ON and the speed regulator is not pressed, release BAS.
No Charging of Battery		
Poor connection	Battery or AC supply not properly connected	Check and reconnect battery and AC power supply separately.
Faulty charger	Charger not functioning	Replace charger.
Faulty battery	Battery defective	Replace battery.
For Professional Repair Only		
ECU reprogramming	New motor controller installed	Some motor controllers may require ECU reprogramming. Refer to service instructions.

Specifications

Motor Type	Brushless
Power Type	Battery
Battery Type	Lithium Ion
Battery Capacity	7.5Ah
Battery Voltage	40V
Runtime	2.5hr (1.5hr @ Max Load)
Drive System	Front Wheel Drive
Brakes	Front Wheel Electronic Brake
Front Wheels	16 × 5.00-8 pneumatic tyres
Finish	Powder Coated
IP Rating	IP54
Bucket material	Polypropylene
Bucket Dimensions	88 x 115 x 30cm
Bucket Volume	300L
Track Width / Tyre Size	16x5.00-8
Max Climb Angle	12° (max 260kg load)
Forward Max Speed	6 km/h
Reverse Max Speed	2 km/h



Some experts believe that the incorrect or prolonged use of almost any product may cause serious injury or death. To help reduce your risk of serious injury or death, refer to the information below. For more information, see www.datastreamserver.com/safety

- Consult all documentation, packaging, and product labelling before use. Note that some products feature documentation available online. It is recommended to print and retain the documentation.
- Before each use, check the product for loose/broken/damaged/missing parts, wear, or leaks (if applicable). Never use a product with loose/broken/damaged/missing parts, wear, or leaks.
- Products must be inspected and serviced (if applicable) by a qualified technician every 6 months. This is based on average residential use by persons of average size and strength, and on a property of average metropolitan size. Use beyond these recommendations may require more frequent inspections/servicing.
- Ensure that all users of the product have completed a suitable industry recognised training course before being allowed access to the product.
- The product has been supplied by a general merchandise retailer that may not be familiar with your specific application or description of application. Be sure to attain third-party approval from a qualified specialist for your application before use, regardless of any assurances from the retailer or its representatives.
- This product is not intended for use where fail-safe operation is required. As with any product (for example, automobile, computer, toaster), there is the possibility of technical issues that may require the repair or replacement of parts, or the product itself. If the possibility of such failure and the associated time it may take to rectify could in any way inconvenience the user, business, or employee, or financially affect the user, business, or employee, then the product is not suitable for your requirements. This product is not intended for use where incorrect operation or a failure of any kind, including but not limited to, a condition requiring product return, replacement, parts replacement, or service by a technician may cause financial loss, loss of employee time or an inconvenience requiring compensation.
- If this product has been purchased in error when considering the information presented here, contact the retailer directly for details of their returns policy, if required.

