



Commercial Soft Ice Cream Equipment

S111 S930T S970T S121

Instructions

PASMO Food Technology Co., Ltd

TAIZHOU PASMO FOOD TECHNOLOGY CO.,LTD
SYSTEM SERVICE PROVIDER FOR ICE CREAM

Service Hotline: 400-7576-999 Sales Hotline: +86(0)576-84088555 website: www.pasmochina.com

- Thank you for choosing the PASMO series soft ice cream equipment.
- This manual will give you a detailed description of the operation and maintenance of the equipment.

Applicable models

Contents

Applicable models	1
Safety precautions	2
Equipment installation	3
Equipment parts	4 ~ 5
Introduction for control panel	6
Display screen content explanation	7
Adjusting method of the hardness value	8
Washing parts	9 ~ 10
Brush usage recommendation	11 ~ 12
Recommendations for wearing parts replacement	13
Assembly method of key parts	14 ~ 17
Ice cream making process	18 ~ 19
Daily operation process	20 ~ 21
Washing process	22 ~ 24
Suggestion for purchasing the accessory products	25



▲ S111



▲ S930T



▲ S121



▲ S970T

Safety precautions

- ◆ Please read and understand the safety precautions carefully before use.
- ◆ Please comply with the safety-related contents described below.
- ◆ The meaning of the logo is stated as follows.

Notes: The equipment should use the power lines of more than 4 square meters.
Pls entrust the electrician to connect the ground wire in advance, otherwise it is easy to cause the electricity leakage and electric shock hazard of personnel.



Ground

It is recommended to install the air switch if the rated power supply is 220V.
Please connect 16A high-power socket if the plug is needed. The blue line N is zero line for 380V. Red, white and black L-lines are live lines. The yellow-green colorlines are ground wire.



Caution

Do not damage the power line, or process, stretch, bundle and bend it, otherwise it may cause electric shock or fire accident.





Forbidden

Do not connect the live line and the zero line in a wrong way, otherwise, it will burn out the equipment main board or transformer.
If three live lines are connected incorrectly, the screen will display "Phase Error" alarm. You need to change the position of each two wires. (Suitable for 380V model)



Forbidden

 Danger! Electric shock!	It is easy to cause electrical shock hazards if you fail to follow the circuit connection in the instructions.
 No disassembly!	The disassembly of equipment by non-professionals may lead to equipment damage.
 Grounding	The equipment must be grounded, otherwise it will easily lead to static electricity.

Equipment installation

Warning

Please entrust the professionals for the equipment installation, otherwise, it is easy to cause the abnormal use of the equipment due to the improper installation.



Entrust professionals

Please install it on a horizontal and firm ground. Otherwise, it may cause equipment dumping, noise and vibration.



Please install horizontally

Do not use the equipment in extremely humid environment, otherwise it is easy to cause equipment electricity leakage and personnel electric shock and other accidents.



Forbidden

Do not use the machine in the places full of sulfates like hot springs or other salty places like bays and salt fields. Otherwise, it may cause internal corrosion and equipment malfunction.



Forbidden

User notes

- Please install it in a well ventilated place. Please reserve more than 30cm for air suction and more than 50cm for heat dissipation for the equipment.
- Do not install in the place which under the direct sunlight or has heating devices nearby. It will result in production capacity decline if it is used under the environmental temperature beyond the range of 5- 38°C.

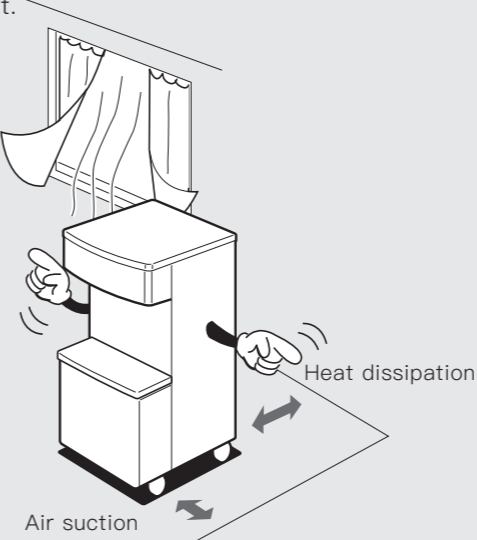

Equipment parts (Gravity model)



Equipment parts (Air pump model)



Introduction for the control panel

Display screen
For detailed digital explanation, please refer to page 6

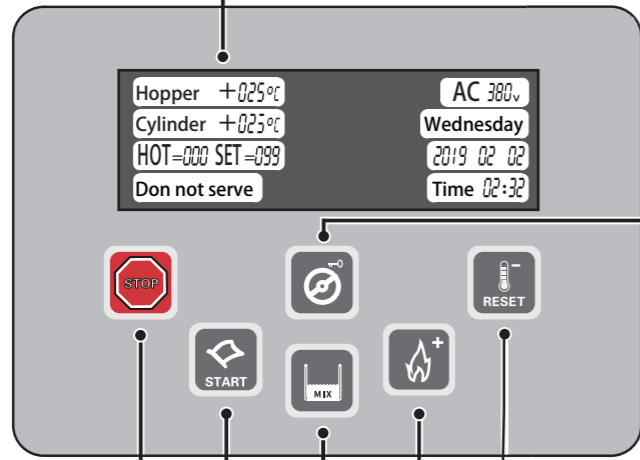

【Stop button】
Press this button for 5 seconds to stop the current working mode and enter into standby state.

【Refrigeration button】
Press this button to enter into the refrigeration mode. The screen displays [Do not serve!];when the screen displays [Product is ready!], you can make ice cream. When making the first batch of ice cream, do not touch the photoelectric sensor switch, otherwise the refrigeration will stop and the operation will be resumed automatically after your hand moves out from the sensor switch.

【Mix low alarm】
If the signal light is on, it means the mixture level in the hopper is too low , and the temperature will be kept between 1~5 °C. The actual preservation period will depend on the real material property used.

【Wash button】
Short press this button, the main motor works only, which is only for cleaning. When the machine is under [Cleaning] mode,the air pump stops working when first short press this button. The main motor stops working when short press this button for the second time. Press this button long to activate the function of [Screen Lock]; press this button long again to unlock.

【RESET Pre-cooling】
Press this button, the machine enters into pre-cooling mode, and the temperature of the unused raw materials left inside the hopper will be kept between 1-5 °C . The preservation period will be different for the different mixture,it depends on the actual situation.Under refrigeration mode, short press this button to decrease the hardness.

【Heating button】
Short press this button to start Heat mode, the machine will stop automatically after the cylinder temperature reach 10 °C. Press this button long to start [Pasteurization]. Under normal circumstances, the duration of no-wash can be extended. Under refrigeration mode, short press this button to increase the hardness.

Display screen content explanation

Digital displays (status display) →

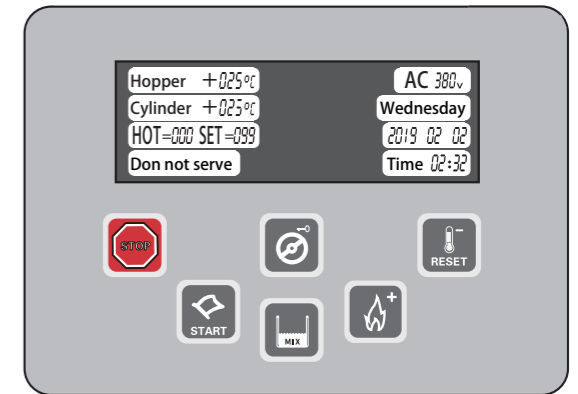

Display	Contents
「Temperature」 Hopper +025°C	It indicates the current temperature of hopper.
「Temperature」 Cylinder +023°C	It indicates the current temperature of the cylinder.
「Hardness」 HOT=000 SET=099	It indicates that the machine is in refrigeration mode. HOT indicates the current hardness value , and SET indicates the setting hardness value .
「Working mode」 Don' t serve	It indicates that the current hardness value has not reached the setting hardness value. When the HOT value rises to the setting hardness value, the screen will display "Product ready" and the ice cream can be made.
「Voltage」 AC 380V	It indicates the current voltage. If the voltage is too low or too high, the machine protection program will be triggered and the machine will be stopped automatically.
「Date」 Wednesday	It indicates the current time.
「Calender」 2019/02/02	
「Time」 时钟 02:32	

Adjusting method of the hardness value

Each raw material has an optimum hardness value corresponding to itself. It is recommended to set the hardness value to 100. The hardness value should not be set too high, otherwise it may cause Frozen Cylinder. Please strictly follow the instructions below.

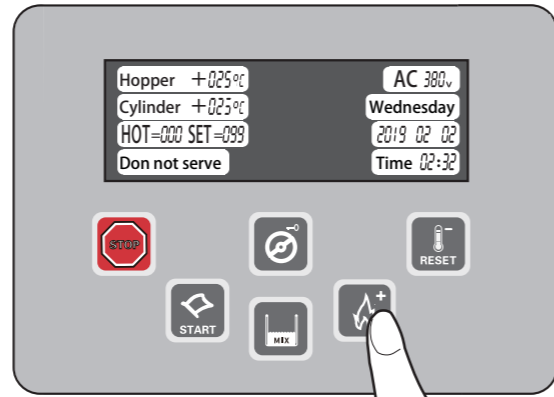

1 In refrigeration mode, press this button to adjust the hardness value. Now SET=092

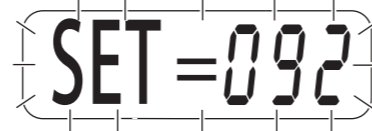

2 Press this button to increase the current hardness value, each time it will be increased by the value "1". SET=093

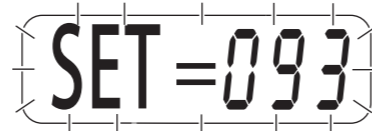

3 Press this button to decrease the current hardness value, each time it will be decreased by the value "1". SET=092

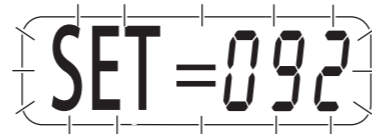

Washing parts (* Applicable to gravity model)

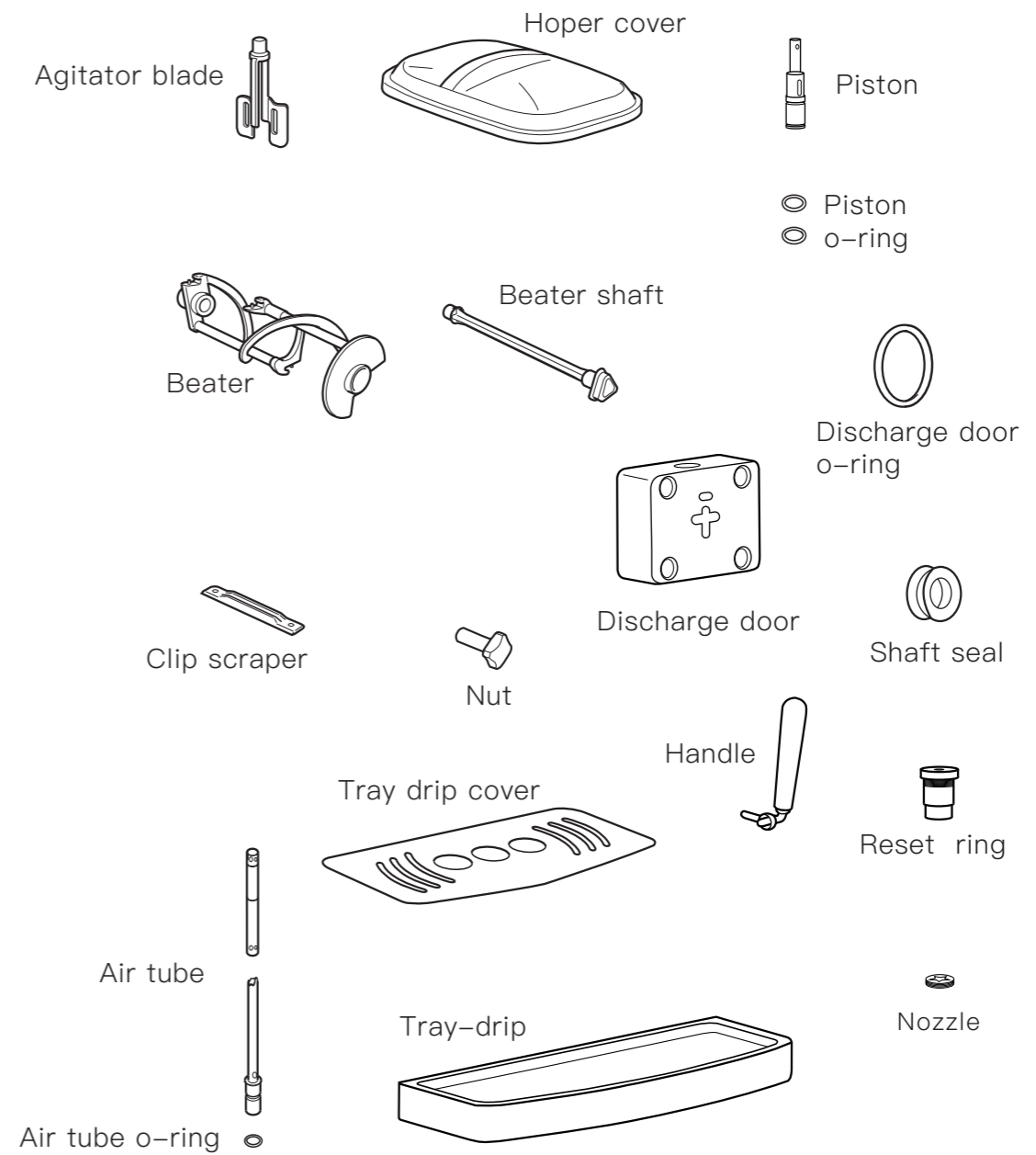

User notes

- Please handle the parts gently and contact the manufacturers for timely replacement if it is damaged or lost.
- Do not wash parts with hot water above 40°C to prevent parts from deformation.
- Do not immerse parts in sterilizing water for more than 30 minutes.

Washing parts (* Applicable to air pump model)

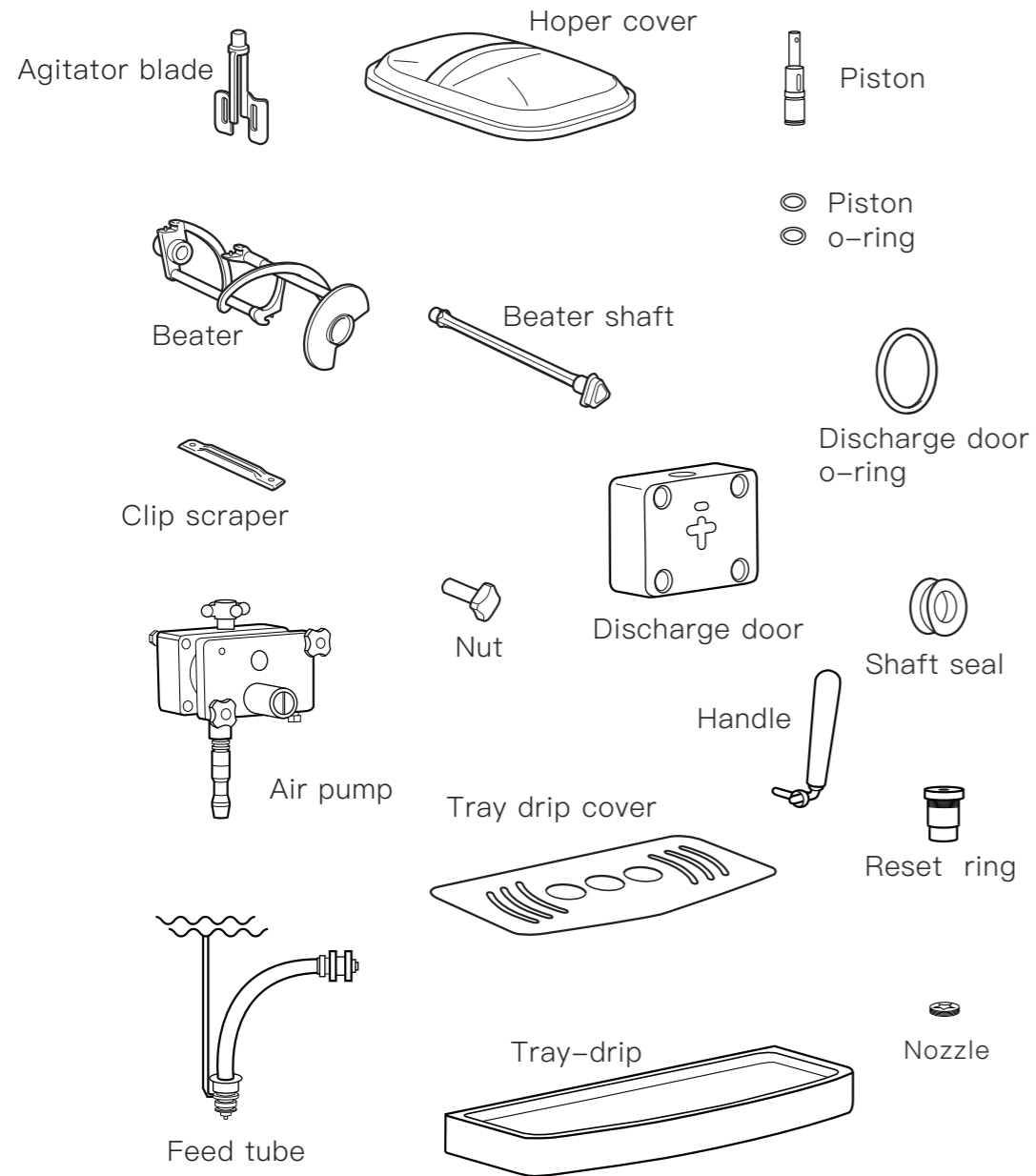

User notes

- Please handle the parts gently and contact the manufacturers for timely replacement if it is damaged or lost.
- Do not wash parts with hot water above 40°C to prevent parts from deforming.
- Do not immerse parts in sterile water for more than 30 minutes.

Brush usage recommendation (* Applicable to gravity model)

Please use the brush attached to the kit for parts washing.

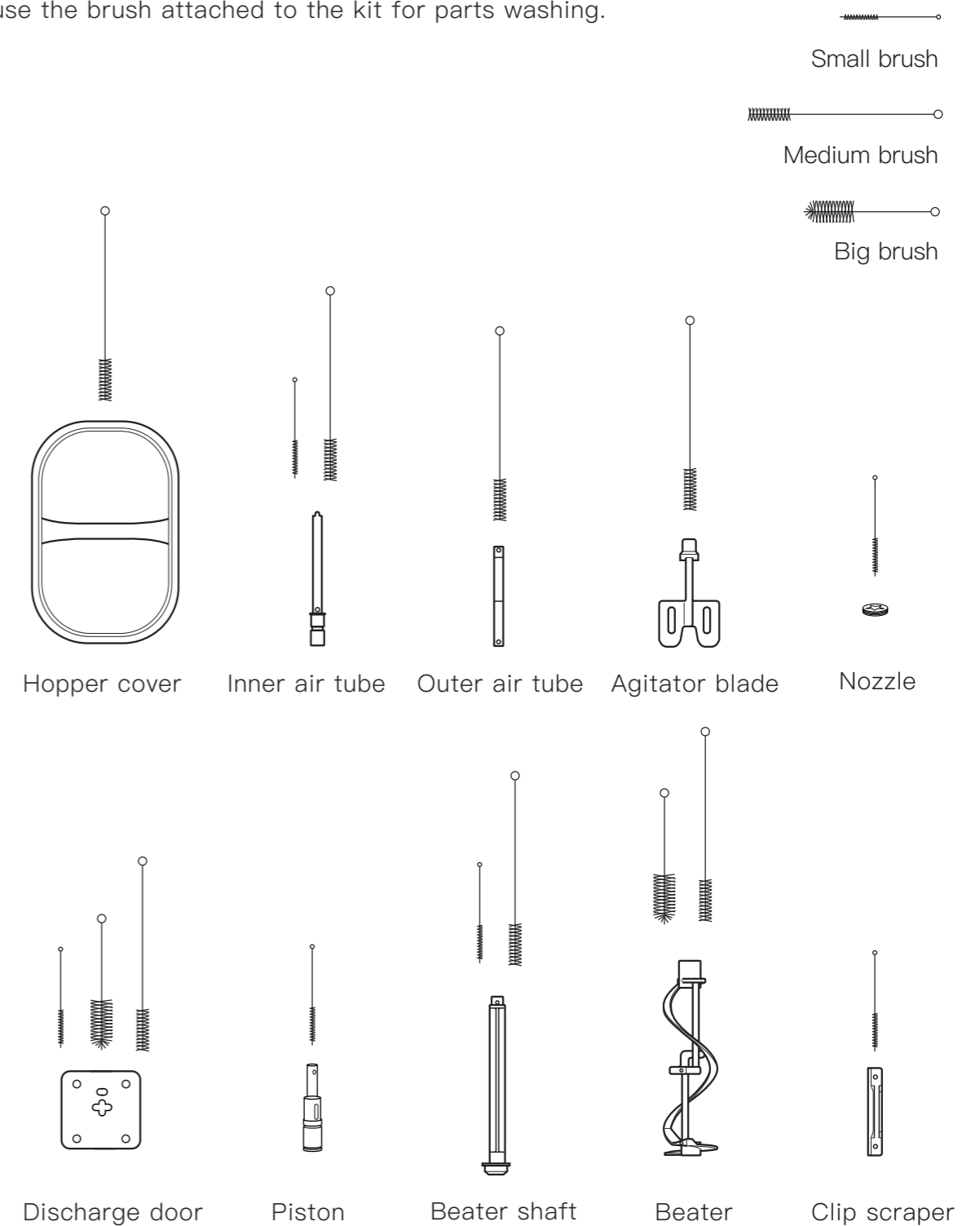

User notes

- Please wash the parts which are connected with the raw materials carefully.
- Pls be careful when washing the clip scrapers because the cutting edge is sharp. It is recommended as well to use special disinfectant powder for washing the equipment.
- The inside of the agitator blade needs to be washed carefully.

Brush usage recommendation

(* Applicable to air pump model)

Please use the brush attached to the kit for parts washing.

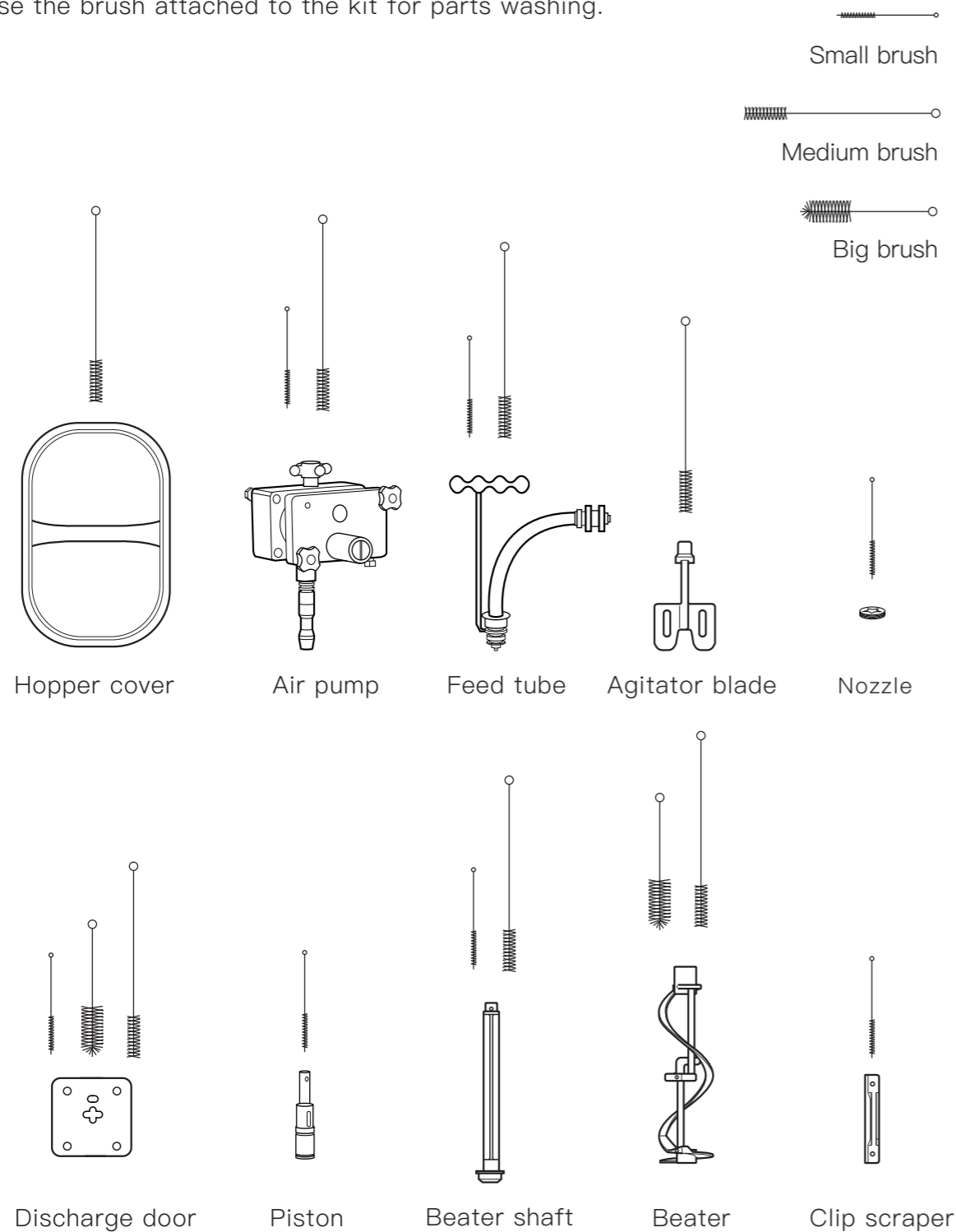

User notes

- Please wash the parts which are connected with the raw materials carefully.
- Pls be careful when washing the clip scrapers because the cutting edge is sharp. It is recommended as well to use special disinfectant powder for washing the equipment.
- The inside of the agitator blade needs to be washed carefully.

Recommendations for wearing parts replacement

- The invisible scratches on the gasket ring may cause the problem of "ice cream leakage". Therefore, it is recommended to replace the o-rings every 3 months. Please replace them right away once you find scratches on them.

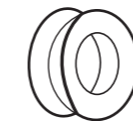

Shaft seal



Piston o-ring

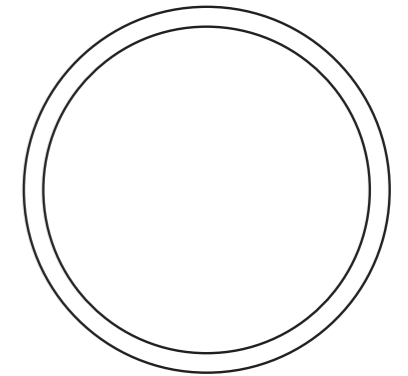

Discharge door o-ring



Air tube o-ring



Air pump o-ring

- The clip scraper wear may cause the ice cream to be too soft and frozen cylinder. Therefore, it is recommended to be replaced every 6 months. Please replace it right away if it's found seriously worn.



Clip scraper



Disinfection powder

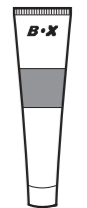

Food grade lube

- The gasket rings shown above need to be coated with proper amount of lubricant before installation.

- Please refer to page 23.24 for the use of stainless steel fin.



Stainless steel fin

- It is recommended to clean the nozzle every day, because it is exposed to the air which will easily breed bacteria.



Nozzle

- If the washing brush is worn or fallen off, it may cause problems such as 'poor washing'. When this happens, please replace with the new brush in time.



Small brush



Medium brush



Big brush

Assembly method of key parts

1 Assembly of beater

Please install the clip scraper and beater shaft on the beater according to the method below.

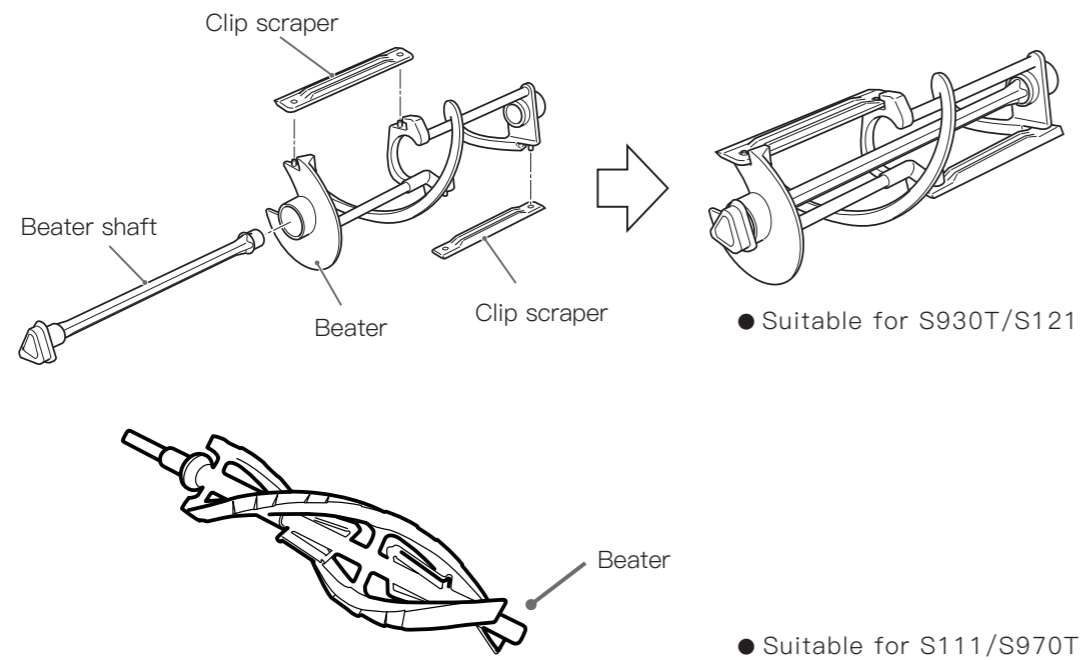

User notes

- The clip scraper has two sides. The side with alphabet is facing upward and fixed through two fixed holes on the blade.
- The clip scraper has a sharp cutting edge. Please be careful during installation. Don't install it in the reversed direction. Otherwise, it may lead to poor taste and frozen cylinder.

2 Beater installation (* Note: Make sure the power switch is off before installation)

Please insert the beater into the cylinder. Slowly rotate with hand while inserting it to the beater motor shaft.

The direction of the beater shaft is  when inserted. (vertex of a triangle upwards) .

Please apply proper amount of lubricating oil on the inner surface of the shaft seal and install it on the main motor shaft.

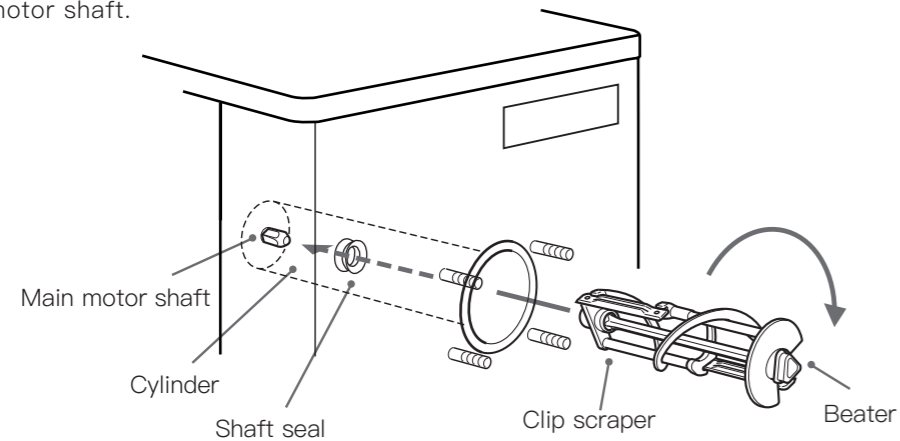

3 Discharge Door Installation

Please apply a small amount of lubricating oil on the discharge door o-ring and piston o-ring.

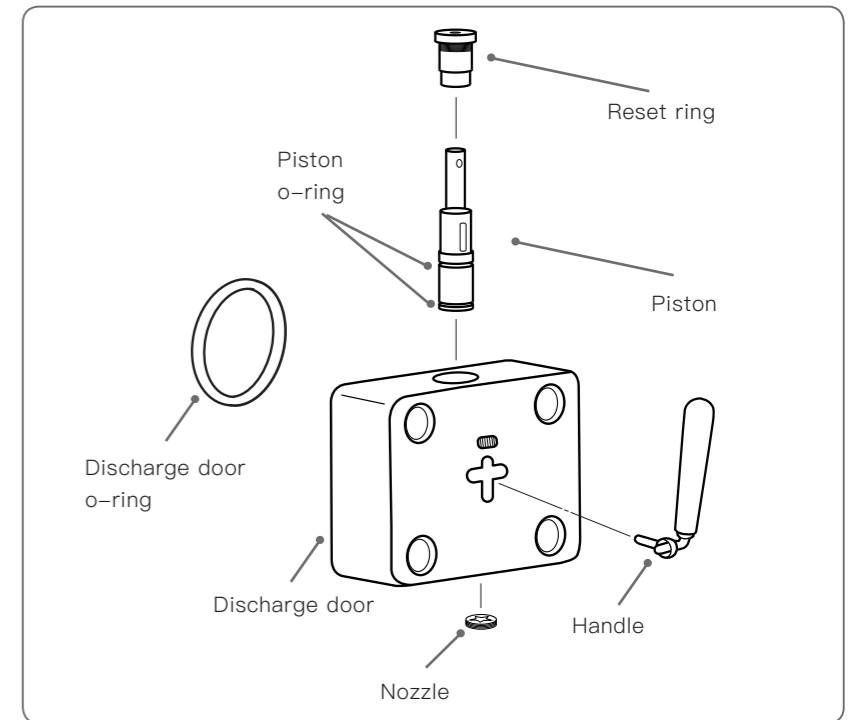

4 Discharge door installation

- ① Make the four fixed holes on the discharge door align with the bolts on the machine and install the discharge door carefully
- ② Install fixed nuts and tighten the four nuts diagonally.

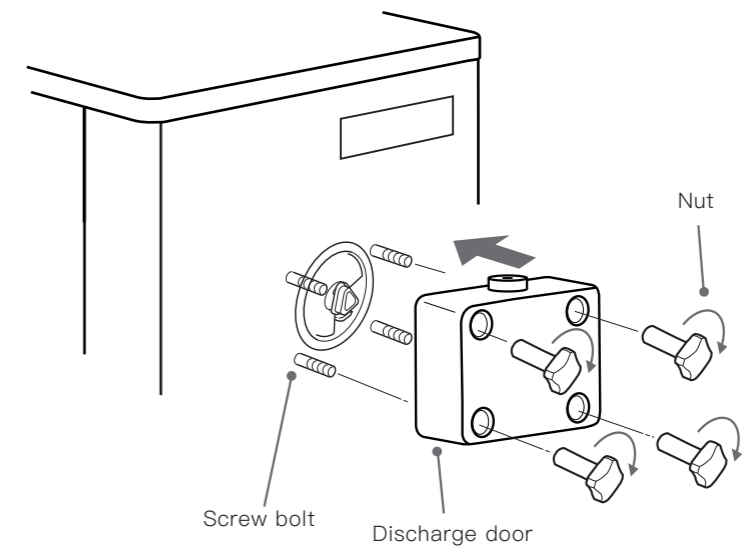

User notes

1. Tighten the nuts diagonally, otherwise it may lead to poor sealing of the discharge door.
2. Poor sealing may lead to ice cream leakage from the crack.

5 Assembly for the air tube

Please check the O-ring carefully at the bottom of the air tube. The outer air tube hole where the protruding part of the inner air tube located is the hole currently used.

When the mixture level is higher than the bottom hole, you can identify the hole used by checking the top outer air tube hole position where the protruding part located.

* Notes: Do not install this accessory before pouring into the mixture. Otherwise, the raw material may not flow into the cylinder completely.

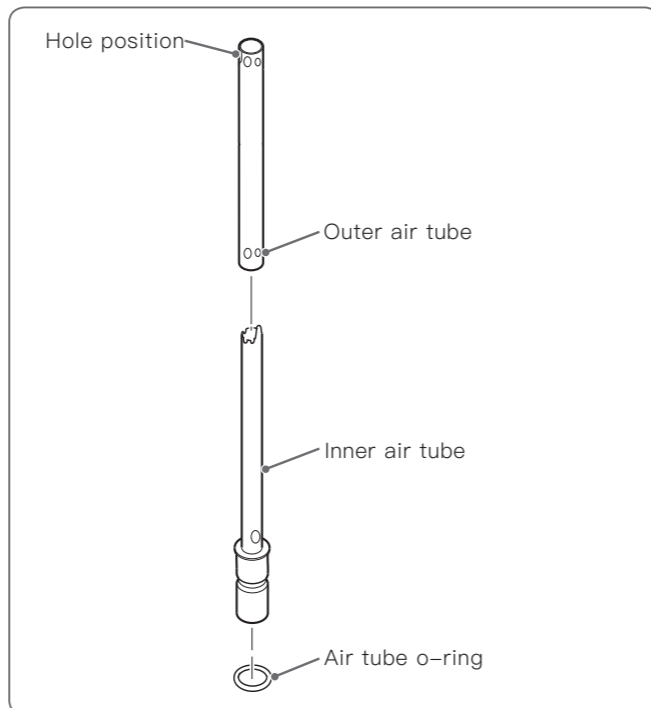

6 Operation for air tube

- Air tube is able to transport raw materials to refrigeration cylinder stably and continuously, to maintain the stability and continuity of ice cream discharging. The hole position of the air tube can be adjusted according to the business conditions. (The adjustment method is as follows.)
- The hole used can be identified according to the outer air tube hole position where the inner protruding part located.

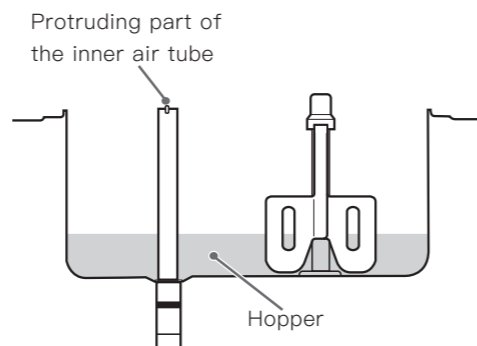

Hole position	Usage condition
Close 	<ul style="list-style-type: none"> ● Raw materials pouring into the equipment to start the ice cream making of the first cylinder. ● Pre-cooling function of raw materials.
Small hole 	<ul style="list-style-type: none"> ● Occasions for normal sales. ● It is usually used when starting business in the morning with small passenger flow.
Medium hole 	<ul style="list-style-type: none"> ● Occasions for normal sales. ● The raw material supplement can follow the amount of ice cream discharging out under the normal traffic.
Big hole 	<ul style="list-style-type: none"> ● Occasions for normal sales. ● A large number of raw materials are needed to added to the refrigeration cylinder with large passenger flow. Big holes are needed to ensure that the thick material of poor fluidity can be added into the cylinder.

Users notes

- Please disinfect hands or put on gloves before touching the air tube.
- We need to choose the appropriate hole size of the air tube hole according to the sales volume. Otherwise, the ice cream will become too soft or too hard to be produced normally.
- Please adjust the hole size to the maximum size or pull it out when cylinder gives out abnormal noise.

5* Assembly for the air pump (Applicable to air pump model)

Make sure that it is lubricated on the gear surfaces and o-rings.

When installing, please make sure that it is flush between the gear and the main body of the air pump. Do not tighten the lock nut one by one, both two sides should be tightened together slowly.

* Note: It is forbidden to make the air pump work if there is no raw material in the hopper, if not so, it will cause the gear to wear out.

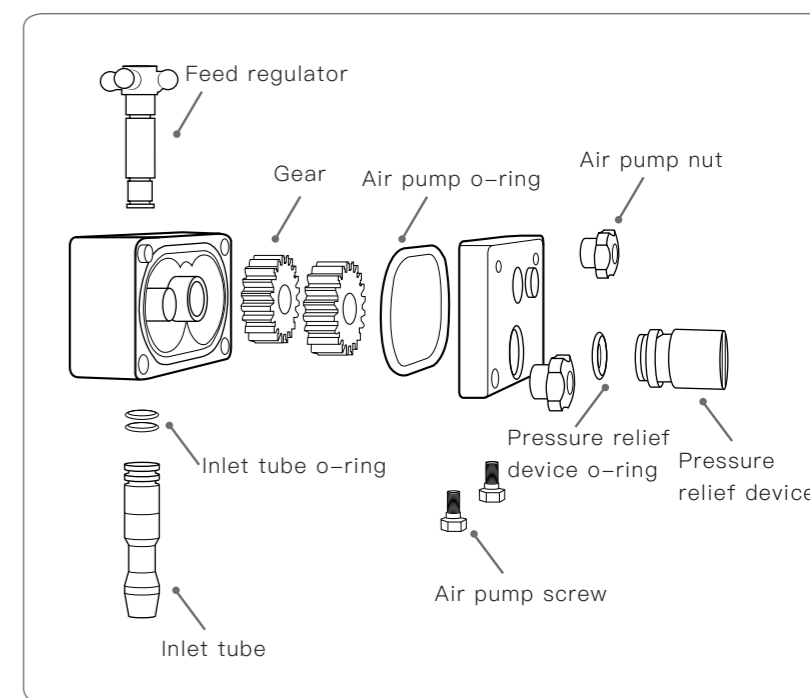

6* How to use the air pump (Applicable to air pump model)

- The air pump can stably and continuously transport the raw materials to the refrigerating cylinder, to maintain the stability and sustainability of the ice cream discharging. Adjust the gear stage of the air pump according to the business conditions. (Please refer to the following figure for adjusting the gear stage)
- The current hole position can be identified by checking the number on the feed regulator which is exactly in front of the air pump cover "dot".

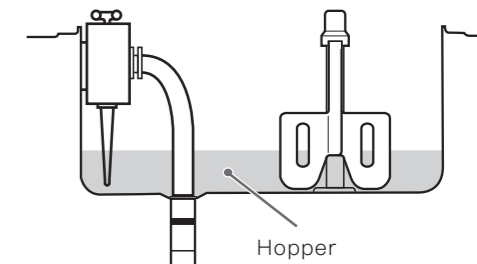

Hole position	Usage occasion
First gear 	<ul style="list-style-type: none"> ● It can be used for special ice cream overrun request (resulting in the highest overrun). ● Pre-cooling function
Second gear 	<ul style="list-style-type: none"> ● Normal sales occasions ● In Normal sales occasions, it can be used to ensure that the raw material supplement can keep up with the amount of ice cream discharging in the morning when the business starts with normal traffic.
Third gear 	<ul style="list-style-type: none"> ● Normal sales occasions
Fourth gear 	<ul style="list-style-type: none"> ● It ensures a large amount of raw material flowing into the cylinder. Big hole positions are needed to ensure that the thick material of poor fluidity can be added into the cylinder.

Precaution

- Disinfect hands or wear gloves before touching the air pump.
- Choose the hole position based on sales volume. Otherwise, the ice cream will be too soft or too hard when discharging out.
- If the cylinder makes abnormal noise, adjust the air pump to the fourth gear or check if material spraying from the pump body or not.

Ice cream making process

(* Applicable to gravity model)

1 Prepare 5L raw materials

Caution: Do not pour anything other than water or raw materials, otherwise, it will cause failure for the equipment. Make sure that the hopper does not have any water remaining before pouring the material.

- ① Before pouring the material, make sure that the storage hopper does not have any water remaining.
- ② If the raw material contains particles such as non-meltable fibers, please contact with PASMO.

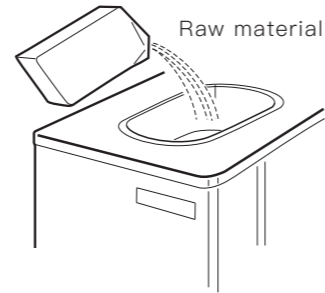

2 Pour the raw materials into the hopper , ensure that the raw material level exceeds the level meter

Precaution

Do not fill the cylinder with material completely. Install the air tube when there is no bubbles coming from the blanking hole any more to ensure that the ice cream produced has a stable expansion rate.

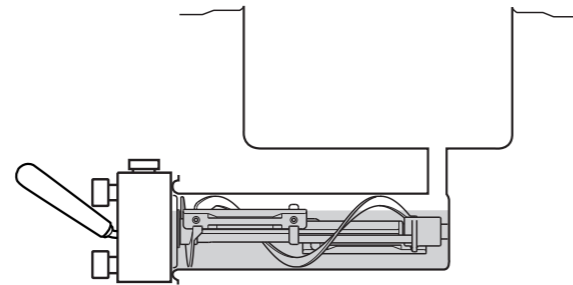

3 Air tube installation

- ① The air tube should be in the status of closed hole. Stop the material from flowing into the cylinder through the feed downpipe so as to ensure that mixture quantity in the refrigeration cylinder is fixed.
- ② Place the hopper cover to prevent foreign objects from falling into the hopper. The mix low alarm on the screen will stop flashing when the material level higher than the level meter
- ③ If the raw material is thick, adjust the air tube to the medium or large hole.

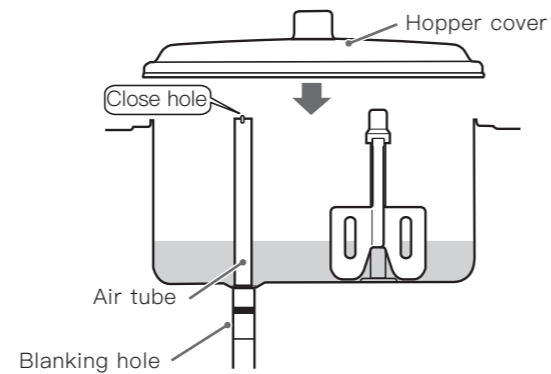

4 Making ice cream

Press START button to make ice cream. When screen shows 'PRODUCT IS READY', it means the ice cream is ready and you can discharge the ice cream. Please adjust the air tube to small or medium hole, or adjust the hole position according to the passenger flow.

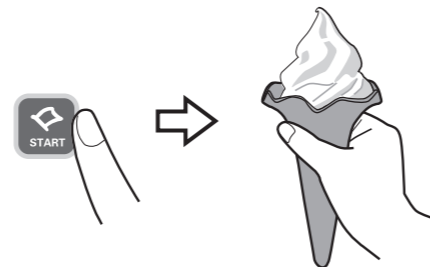

Ice cream making process

(* Applicable to air pump model)

1 Prepare 5L raw materials

Caution: Do not pour anything other than water or raw materials, otherwise, it will cause failure for the equipment. Make sure that the hopper does not have any water remaining before pouring the material.

- ① Before pouring the material, make sure that the storage hopper does not have any water remaining.
- ② If the raw material contains particles such as non-meltable fibers, please contact with PASMO.

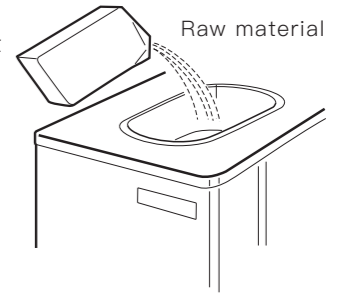

2 Pour the raw materials into the hopper , ensure that the raw material level exceeds the level meter

Precaution

Do not fill the cylinder with material completely. Install the air tube when there is no bubbles coming from the blanking hole any more to ensure that the ice cream produced has a stable expansion rate.

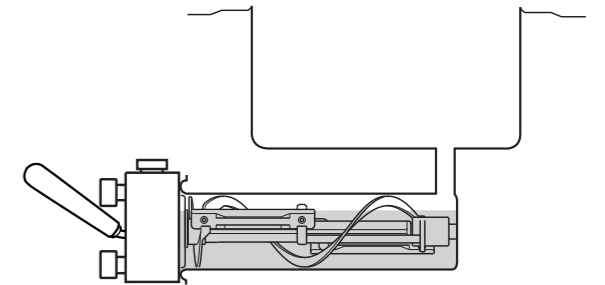

3 Install the air pump and feeding tube

- ① After installing the air pump and the feeding tube , adjust the air pump to 2nd gear.
- ② Place the hopper cover to prevent foreign matter from falling into the hopper. When the material level exceeds the level meter, the indicator on the screen will stop flashing.
- ③ If the raw material is thick, please adjust the air pump to 3rd or 4th gears.

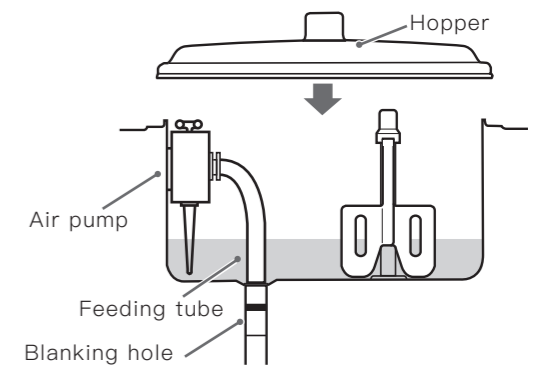

4 Making ice cream

Press the [START] button to wait for the ice cream to be ready. When the screen shows "Product is ready", it indicates that the current ice cream has been formed and you can discharge ice cream. Adjust the gear of the air pump according to the traffic to prevent the frozen cylinder.

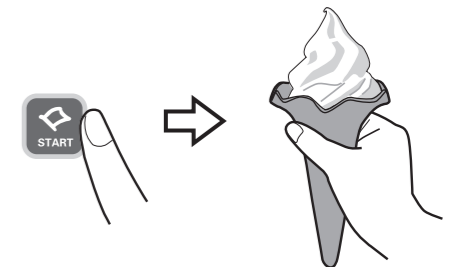

Daily operation process (* Applicable to gravity model)

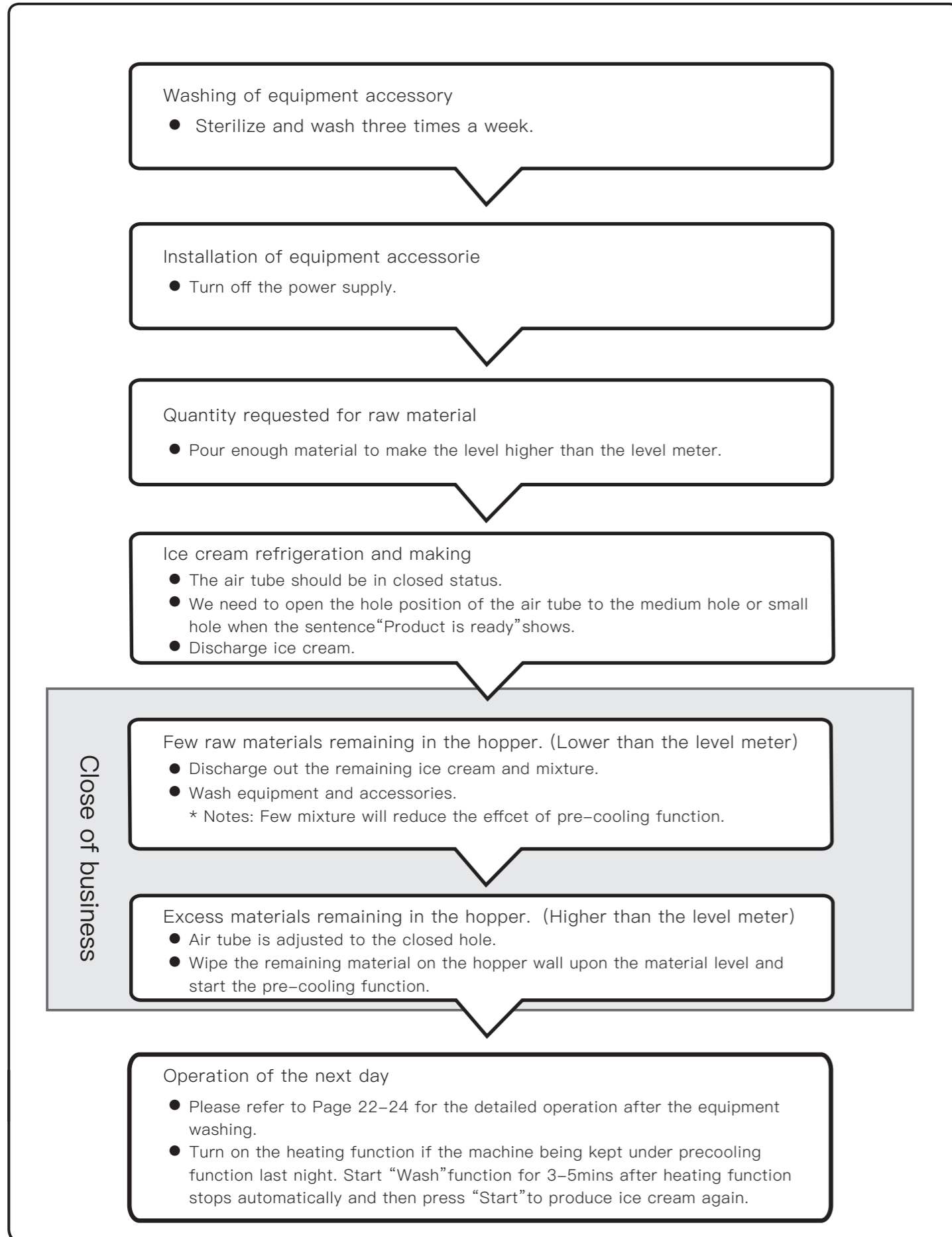

Daily operation process (* Applicable to air pump model)

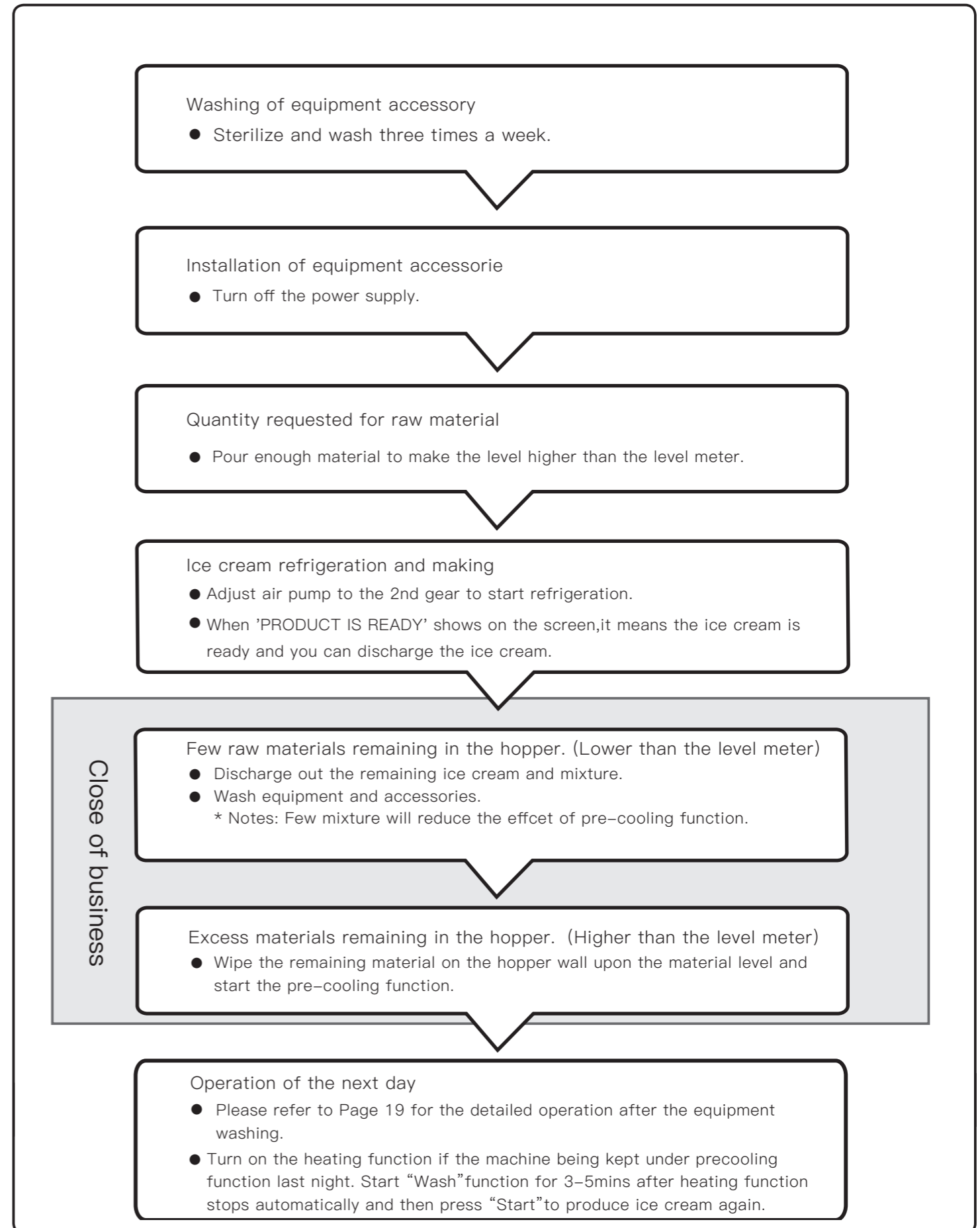

Washing process

- 1** Ratio of food-grade disinfectant powder for machine washing and disinfection.
The ratio is 1:9.5L (1 bag of sanitizer and 9.5L water).

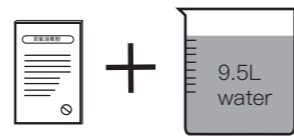

- 2** Install the agitator blade back into the hopper.

- 3** Turn on the power switch. Do not press the WASH button if there is no water or raw materials in the cylinder to prevent the clip scrapers from wearing.

- 4** Pour 5L disinfectant water in total into the hopper. Press the WASH key to start the device.
Press the STOP button to stop after working for 1–2 minutes.

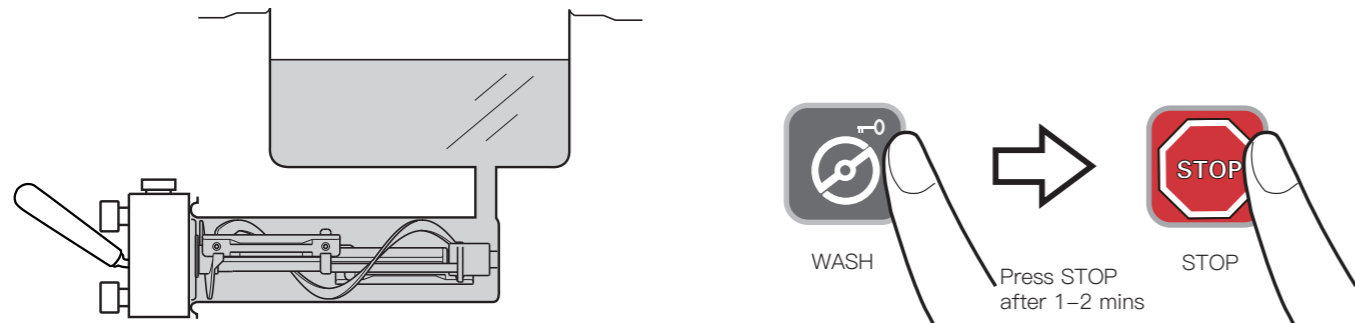

- 5** Please wash the hopper with the brush and disinfectant water for 2–3 times.
- Please clean the blanking hole with big brush carefully.
 - Please wash the level meter with medium brush.
 - Please wash the agitator shaft with small brush.

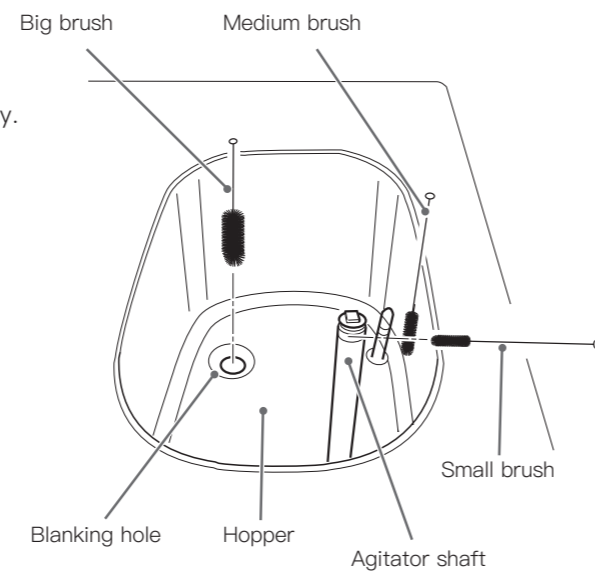

- 6** Please discharge the remaining disinfectant water in the equipment by using the drainage box.

- Fix the contraction band of the drainage box on the top two nuts of the discharge door.
- Press the handle down to discharge the disinfectant water.

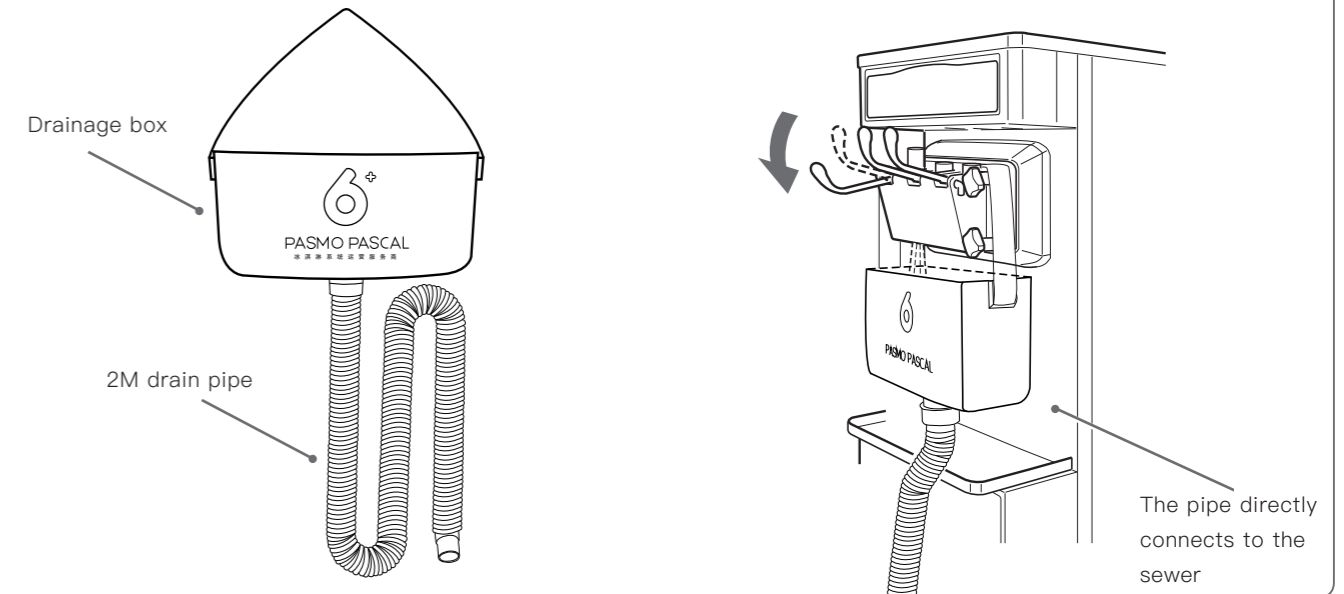

- 7** Please pour a proper amount of clean water into the hopper after the discharge of disinfectant water and repeat the above steps for 2 to 3 times.

- 8** Please disassemble the drainage box after drainage and wipe inner drainage box clean with a towel and keep it in a cool place.
Please wipe the refrigeration cylinder and hopper with a clean towel.

- 9** Make sure to turn off the power supply to avoid unnecessary safety hazards for the part washing.

- Please remove the piston O-ring by using stainless steel fin in the accessory kits.
- Please wash the piston groove with a small brush.

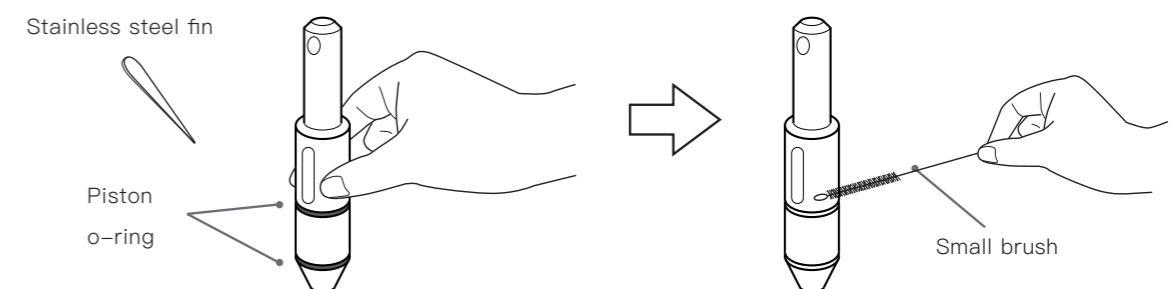

10* Note: Make sure the air pump is completely disassembled and cleaned
(Applicable to the air pump model)

- Use the wrench in the kit bag to disassemble the pressure relief device and fixing nut, then clean them.

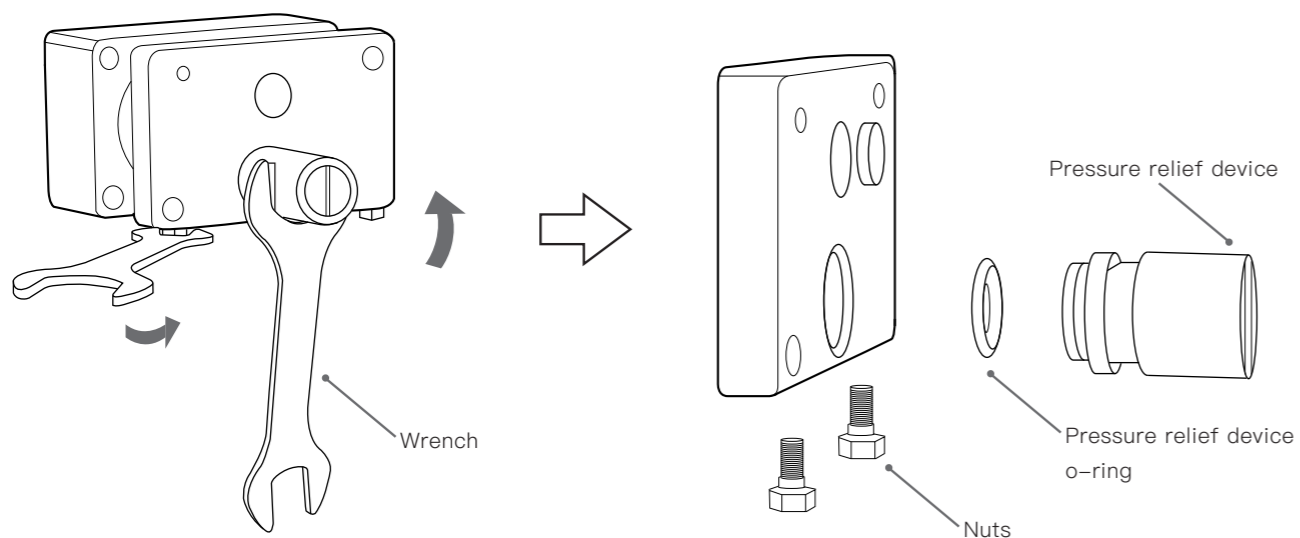

11* Note: Make sure the feeding tube is completely disassembled and cleaned
(Applicable to the air pump model)

- Please use the stainless steel fin in the kit bag to remove the automatic pressure relief valve, then clean it.

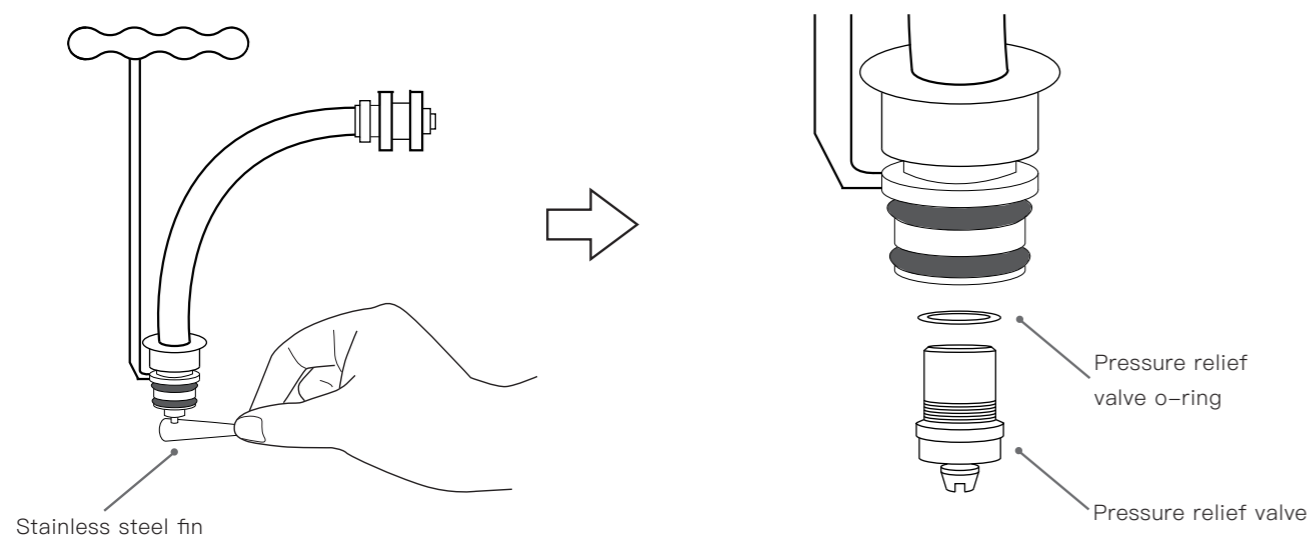

Suggestion for purchasing the accessory products

- Height is 153cm, large ice cream lamp model



- Height is 136cm, medium ice cream lamp model



- Height is 45cm, small ice cream lamp model



- Desktop ice cream model



- Usage for the drainage box, please refer to the page 23

