

**Bäumr-AG®**

**CSE-85  
ELECTRIC  
CONCRETE SAW**



## **User Manual**

[Revision 2.0]

---

**READ THIS MANUAL CAREFULLY BEFORE USE – FAILURE TO DO SO MAY RESULT IN INJURY, PROPERTY DAMAGE AND MAY VOID WARRANTY. • KEEP THIS MANUAL FOR FUTURE REFERENCE. • Products covered by this manual may vary in appearance, assembly, inclusions, specifications, description, and packaging.**

---

# Safety

Safety messages are designed to alert you to possible dangers or hazards that could cause death, injury or equipment or property damage if not understood or followed. Safety messages have the following symbols:



You **WILL** be **KILLED** or **SERIOUSLY INJURED** if you do not follow instructions.



You **CAN** be **KILLED** or **SERIOUSLY INJURED** if you do not follow instructions.



You **CAN** be **INJURED** if you do not follow instructions or equipment damage may occur.

It is vital that you read and understand this user manual before using the product, including safety warnings, and any assembly and operating instructions. Keep the manual for future reference.

Safety precautions and recommendations detailed here must be fully understood and followed to reduce the risk of injury, fire, explosion, electrical hazard, and/or property damage.

Safety information presented here is generic in nature – some advice may not be applicable to every product. The term "equipment" refers to the product, be it electrical mains powered, battery powered or combustion engine powered.

- **Before Use** - If you are not familiar with the safe operation/handling of the equipment or are in any way unsure of any aspect of suitability or correct use for your application, you should complete training conducted by a person or organization qualified in safe use and operation of this equipment, including fuel/electrical handling and safety.
- Do NOT operate the equipment in flammable or explosive environments, such as in the presence of flammable liquids, gases, or dust. The equipment may create sparks or heat that may ignite flammable substances.
- Keep clear of moving parts.
- Equipment may be a potential source of electric shock or injury if misused.
- Do NOT operate the equipment if it is damaged, malfunctioning or is in an excessively worn state.
- Do NOT allow others to use the equipment unless they have read this manual and are adequately trained.
- Keep packaging away from children - risk of suffocation! Operators must use the equipment correctly. When using the equipment, consider conditions and pay due care to persons and property.

## General Work Area Safety

- Work areas should be clean and well lit.
- Do not operate the equipment if bystanders, animals etc are within operating range of the equipment or the general work area.
- If devices are provided for connecting dust extraction / collection facilities, ensure these are connected and used properly. Dust collection can reduce dust-related hazards.

## General Personal Safety

- Wear appropriate protective equipment when operating, servicing, or when in the operating area of the equipment to help protect from eye and ear injury, poisoning, burns, cutting and crush injuries. Protective equipment such as safety goggles, respirators, non-slip safety footwear, hard hat, hearing protection etc should be used for appropriate equipment / conditions. Other people nearby should also wear appropriate personal protective equipment. Do not wear loose clothing or jewellery, which can be caught in moving parts. Keep hair and clothing away from the equipment.
- Stay alert and use common sense when operating the equipment. Do not over-reach. Always maintain secure footing and balance.
- Do not use the equipment if tired or under the influence of drugs, alcohol, or medication.
- This equipment is not intended for use by persons with reduced physical, sensory, or mental capabilities.

## General Fuel Safety

- Petrol/fuel/gasoline is extremely flammable – keep clear of naked flames or other ignition sources.
- Do not spill fuel. If you spill fuel, wipe it off the equipment immediately – if fuel gets on your clothing, change clothing.
- Do NOT smoke near fuel or when refuelling.
- Always shut off the engine before refuelling.
- Do NOT refuel a hot engine.
- Open the fuel cap carefully to allow any pressure build-up in the tank to release slowly.
- Always refuel in well-ventilated areas.
- Always check for fuel leakage. If fuel leakage is found, do not start, or run the engine until all leaks are fixed.

## General Carbon-Monoxide Safety

- Using a combustion engine indoors **CAN KILL IN MINUTES**. Engine exhaust contains carbon-monoxide – a poison you cannot smell or see.
- Use combustion engines **OUTSIDE** only, and far away from windows, doors, and vents.

## General Equipment Use and Care

- Keep packaging away from children and pets, potential risk of suffocation or choking.
- The equipment is designed for domestic use only.
- Handle the equipment safely and carefully.
- Before use, inspect the equipment for misalignment or binding of moving parts, loose components, damage, or any other condition that may affect its operation. If damaged, have the equipment repaired by an authorised service centre or technician before use.
- Prevent unintentional starting of the equipment - ensure equipment and power switches are in the OFF position before connecting or moving equipment. Do not carry equipment with hands or fingers touching any controls. Remove any tools or other items that are not a part of the equipment from it before starting or switching on.
- Do not force the equipment. Use the correct equipment for your application. Equipment will perform better and be safer when used within its design and usage parameters.
- Use the equipment and accessories etc. in accordance with these instructions, considering working conditions and the work to be performed. Using the equipment for operations different from those intended could result in hazardous situations.
- Always keep equipment components (engines, hoses, handles, controls, frames, housings, guards etc) and accessories (cutting tools, nozzles, bits etc) properly maintained. Keep the equipment clean and, where applicable, properly lubricated.
- Store the equipment out of reach of children or untrained persons. To avoid burns or fire hazards, let the equipment cool completely before transporting or storing. Never place or store the equipment near flammable materials, combustible gases, or liquids etc.
- The equipment is not weather-proof, and should not be stored in direct sunlight, at high ambient temperatures or locations that are damp or humid.
- Do not clean equipment with solvents, flammable liquids, or harsh abrasives.
- For specific equipment safety use and care, see Equipment Safety.

### General Electrical Safety

- Inspect electrical equipment, extension cords, power bars, and electrical fittings for damage or wear before each use. Repair or replace damaged equipment immediately.
- Ensure all power sources conform to equipment voltage requirements and are disconnected before connecting or disconnecting equipment.
- When wiring electrically powered equipment, follow all electrical and safety codes.
- Always use a Residual Current Device (RCD) (GFCI) / Earth Leakage Circuit Breaker / Safety Switch when operating this item (electrical items only).
- High voltage / high current power lines may be present. Use extreme caution to avoid contact or interference with power lines. Electrical shock can be fatal.

### General Electrical Safety

- Electrically grounded equipment must have an approved cord and plug and be connected to a grounded electrical outlet.
- Do NOT bypass the ON/OFF switch and operate equipment by connecting and disconnecting the electrical cord.
- Do NOT use equipment that has exposed wiring, damaged switches, covers or guards.
- Do NOT use electrical equipment in wet conditions or in damp locations.
- Do NOT use electrical cords to lift, move or carry equipment.
- Do NOT coil or knot electrical cords, and ensure electrical cords are not trip hazards.

### General Service Information

- The equipment must be serviced or repaired at authorised service centres by qualified personnel only.
- Replacement parts must be original equipment manufacturer (OEM) to ensure equipment safety is maintained.
- Do NOT attempt any maintenance or repair work not described in this manual.
- After use, the equipment and components may still be hot – allow the equipment to cool and disconnect spark plugs and/or electrical power sources and/or batteries from it before adjusting, changing accessories, or performing repair or maintenance.
- Do NOT adjust while the equipment is running.
- Perform service-related activities in suitable conditions, such as a workshop.
- Replace worn, damaged or missing warning/safety labels immediately.

### Child Choking Hazard!



• **WARNING: CHOKING HAZARD - CHILDREN UNDER 8 YRS. CAN CHOKE OR SUFFOCATE ON SMALL PARTS. ADULT SUPERVISION REQUIRED.**

- Carefully inspect anything a baby or child could gain access to, including this product & packaging.
- Dangers include anything of a size that could become stuck or lodged in a baby or child's airway.
- Dangers include things like raw, hard fruit and vegetable pieces, large pieces of meat, bones or sausage skins, popcorn, nuts, hard lollies and corn chips, small magnets and batteries, coins, beads, marbles and small uninflated balloons, broken toys and smaller toys, buttons, keys, and coins. But there are also many more.
- Pay particular attention to accessories, nuts, bolts, screws, washers, caps, covers, loose parts, parts that could be removed or break off, pieces of packaging, staples, tape etc.
- In the case of any doubt, secure the item of concern in an appropriate manner, or completely remove the possibility of access by a baby or child.

### WARNING!

- **BE AWARE THAT THE EQUIPMENT MAY INCLUDE HAZARDOUS COMPONENTS, SUCH AS BLADES, HOT SURFACES AND MOVING PARTS.**
- **MOVING BLADES CAN CAUSE SERIOUS INJURY AND EVEN DEATH IF USED IMPROPERLY OR WITHOUT SUFFICIENT PPE.**
- **DO NOT USE THIS EQUIPMENT ON UNEVEN SURFACES AND ALWAYS MAINTAIN GOOD BALANCE WHEN USING THIS EQUIPMENT. FAILURE TO DO SO MAY CAUSE SERIOUS INJURY.**
- **MAINTAIN A SECURE GRIP OF THE TRIGGER ASSEMBLY AT ALL TIMES.**

### General Power Tool Safety Warnings

- **WARNING! READ ALL SAFETY WARNINGS AND ALL INSTRUCTIONS. FAILURE TO FOLLOW THE WARNINGS AND INSTRUCTIONS MAY RESULT IN ELECTRIC SHOCK, FIRE AND/OR SERIOUS INJURY.**
- Save all warnings and instructions for future reference. The term "power tool" in the warnings refers to your mains operated (corded) power tool or battery-operated (cordless) power tool.

### General Power Tool Safety Warnings - Work Area Safety

- Keep work area clean and well lit. Cluttered or dark areas invite accidents.
- Do not operate power tools in explosive atmospheres, such as in the presence of flammable liquids, gases, or dust. Power tools create sparks which may ignite the dust or fumes.
- Keep children and bystanders away while operating a power tool. Distractions can cause you to lose control.

### General Power Tool Safety Warnings - Electrical Safety

- Power tool plugs must match the outlet. Never modify the plug in any way. Do not use any adapter plugs with earthed (grounded) power tools. Unmodified plugs and matching outlets will reduce risk of electric shock.
- Avoid body contact with earthed or grounded surfaces such as pipes, radiators, ranges, and refrigerators. There is an increased risk of electric shock if your body is earthed or grounded.
- Do not expose power tools to rain or wet conditions. Water entering a power tool will increase the risk of electric shock.
- Do not abuse the cord. Never use the cord for carrying, pulling, or unplugging the power tool.
- Keep cord away from heat, oil, sharp edges or moving parts. Damaged or entangled cords increase the risk of electric shock.
- When operating a power tool outdoors, use an extension cord suitable for outdoor use. Use of a cord suitable for outdoor use reduces the risk of electric shock.

- If operating a power tool in a damp location is unavoidable, use a residual current device (RCD) protected supply. Use of an RCD reduces the risk of electric shock.

#### General Power Tool Safety Warnings - Personal Safety

- Stay alert, watch what you are doing and use common sense when operating a power tool. Do not use a power tool while you are tired or under the influence of drugs, alcohol or medication. A moment of inattention while operating power tools may result in serious personal injury.
- Use personal protective equipment. Always wear eye protection. Protective equipment such as dust mask, non-skid safety shoes, hard hat, or hearing protection used for appropriate conditions will reduce personal injuries.
- Prevent unintentional starting. Ensure the switch is in the off position before connecting to power source and/or battery pack, picking up or carrying the tool. Carrying power tools with your finger on the switch or energising power tools that have the switch on invites accidents.
- Remove any adjusting key or wrench before turning the power tool on. A wrench or a key left attached to a rotating part of the power tool may result in personal injury.
- Do not overreach. Keep proper footing and balance at all times. This enables better control of the power tool in unexpected situations.
- Dress properly. Do not wear loose clothing or jewellery. Keep your hair, clothing, and gloves away from moving parts. Loose clothes, jewellery or long hair can be caught in moving parts.
- If devices are provided for the connection of dust extraction and collection facilities, ensure these are connected and properly used. Use of dust collection can reduce dust-related hazards.

#### General Power Tool Safety Warnings- Power Tool Use and Care

- Do not force the power tool. Use the correct power tool for your application. The correct power tool will do the job better and safer at the rate for which it was designed.
- Do not use the power tool if the switch does not turn it on and off. Any power tool that cannot be controlled with the switch is dangerous and must be repaired.
- Disconnect the plug from the power source and/or the battery pack from the power tool before making any adjustments, changing accessories, or storing power tools. Such preventive safety measures reduce the risk of starting the power tool accidentally.
- Store idle power tools out of the reach of children and do not allow persons unfamiliar with the power tool or these instructions to operate the power tool. Power tools are dangerous in the hands of untrained users.
- Maintain power tools. Check for misalignment or binding of moving parts, breakage of parts and any other condition that may affect the power tool's operation. If damaged, have the power tool repaired before use. Many accidents are caused by poorly maintained power tools.
- Keep cutting tools sharp and clean. Properly maintained cutting tools with sharp cutting edges are less likely to bind and are easier to control.
- Use the power tool, accessories, and tool bits etc., in accordance with these instructions, taking into account the working conditions and the work to be performed. Use of the power tool for operations different from those intended could result in a hazardous situation.

#### General Power Tool Safety Warnings- Service

- Have your power tool serviced by a qualified repair person using only identical replacement parts. This will ensure that the safety of the power tool is maintained.

#### Cut-Off Machine Safety Warnings

- The guard provided with the tool must be securely attached to the power tool and positioned for maximum safety, so the least amount of wheel is exposed towards the operator. Position yourself and bystanders away from the plane of the rotating wheel. The guard helps to protect operator from broken wheel fragments and accidental contact with wheel.
- Use only diamond or abrasive cut off wheels for your power tool. Just because an accessory can be attached to your power tool, it does not assure safe operation.
- The rated speed of the accessory must be at least equal to the maximum speed marked on the power tool. Accessories running faster than their rated speed can break and fly apart.
- Wheels must be used only for recommended applications. For example: do not grind with the side of a cut-off wheel. Abrasive cut-off wheels are intended for peripheral grinding, side forces applied to these wheels may cause them to shatter.
- Always use undamaged wheel flanges that are of correct diameter for your selected wheel. Proper wheel flanges support the wheel thus reducing the possibility of wheel breakage.
- The outside diameter and the thickness of your accessory must be within the capacity rating of your power tool. Incorrectly sized accessories cannot be adequately guarded or controlled.
- The arbour size of wheels and flanges must properly fit the spindle of the power tool. Wheels and flanges with arbour holes that do not match the mounting hardware of the power tool will run out of balance, vibrate excessively and may cause loss of control.
- Do not use damaged wheels. Before each use, inspect the wheels for chips and cracks. If power tool or wheel is dropped, inspect for damage, or install an undamaged wheel. After inspecting and installing the wheel, position yourself and bystanders away from the plane of the rotating wheel and run the power tool at maximum no load speed for one minute. Damaged wheels will normally break apart during this test time.
- Wear personal protective equipment. Depending on application, use face shield, safety goggles or safety glasses. As appropriate, wear dust mask, hearing protectors, gloves, and shop apron capable of stopping small abrasive or workpiece fragments. The eye protection must be capable of stopping flying debris generated by various operations. The dust mask or respirator must be capable of filtering particles generated by your operation. Prolonged exposure to high intensity noise may cause hearing loss.
- Keep bystanders a safe distance away from work area. Anyone entering the work area must wear personal protective equipment. Fragments of workpiece or of a broken wheel may fly away and cause injury beyond immediate area of operation.
- Hold the power tool by insulated gripping surfaces only, when performing an operation where the cutting accessory may contact hidden wiring or its own cord. Cutting accessory contacting a "live" wire may make exposed metal parts of the power tool "live" and could give the operator an electric shock.
- Position the cord clear of the spinning accessory. If you lose control, the cord may be cut or snagged, and your hand or arm may be pulled into the spinning wheel.

**CSE-85 Electric Concrete Saw**

- Never lay the power tool down until the accessory has come to a complete stop. The spinning wheel may grab the surface and pull the power tool out of your control.
- Do not run the power tool while carrying it at your side. Accidental contact with the spinning accessory could snag your clothing, pulling the accessory into your body.
- Regularly clean the power tool's air vents. The motor's fan will draw the dust inside the housing and excessive accumulation of powdered metal may cause electrical hazard s.
- Do not operate the power tool near flammable materials. Sparks could ignite these materials.

**Cut-Off Machine Safety Warnings - Kickback and Related Warnings**

- Kickback is a sudden reaction to a pinched or snagged rotating wheel. Pinching or snagging causes rapid stalling of the rotating wheel which in turn causes the uncontrolled power tool to be forced in the direction opposite of the wheel's rotation at the point of the binding.
- For example, if an abrasive wheel is snagged or pinched by the workpiece, the edge of the wheel that is entering into the pinch point can dig into the surface of the material causing the wheel to climb out or kick out. The wheel may either jump toward or away from the operator, depending on direction of the wheel's movement at the point of pinching. Abrasive wheels may also break under these conditions.
- Kickback is the result of power tool misuse and/or incorrect operating procedures or conditions and can be avoided by taking proper precautions as given below.
  - Maintain a firm grip on the power tool and position your body and arm to allow you to resist kickback forces. Always use auxiliary handle, if provided, for maximum control over kickback or torque reaction during start-up. The operator can control torque reactions or kickback forces if proper precautions are taken.
  - Never place your hand near the rotating accessory. Accessory may kickback over your hand.
  - Do not position your body in line with the rotating wheel. Kickback will propel the tool in direction opposite to the wheel's movement at the point of snagging.
  - Use special care when working corners, sharp edges etc. Avoid bouncing and snagging the accessory. Corners, sharp edges or bouncing have a tendency to snag the rotating accessory and cause loss of control or kickback.
  - Do not attach a saw chain, woodcarving blade, segmented diamond wheel with a peripheral gap greater than 10mm or toothed saw blade. Such blades create frequent kickback and loss of control.
  - Do not "jam" the wheel or apply excessive pressure. Do not attempt to make an excessive depth of cut. Overstressing the wheel increases the loading and susceptibility to twisting or binding of the wheel in the cut and the possibility of kickback or wheel breakage.
  - When wheel is binding or when interrupting a cut for any reason, switch off the power tool and hold the power tool motionless until the wheel comes to a complete stop. Never attempt to remove the wheel from the cut while the wheel is in motion otherwise kickback may occur. Investigate and take corrective action to eliminate the cause of wheel binding.
  - Do not restart the cutting operation in the workpiece. Let the wheel reach full speed and carefully re-enter the cut. The wheel may bind, walk up or kickback if the power tool is restarted in the workpiece.
  - Support panels or any oversized workpiece to minimize the risk of wheel pinching and kickback. Large workpieces tend to sag under their own weight. Supports must be placed under the workpiece near the line of cut and near the edge of the workpiece on both sides of the wheel.
  - Use extra caution when making a "pocket cut" into existing walls or other blind areas. The protruding wheel may cut gas or water pipes, electrical wiring or objects that can cause kickback.

**Cut-Off Machine Safety Warnings -Additional Safety Rules**

- **WARNING: AVOID CUTTING IN THE UPPER QUADRANT OF THE BLADE, ESPECIALLY WHEN BEGINNING THE CUT. THIS AREA IS HIGHLY LIKELY TO LEAD TO KICKBACK.**
- **WARNING: WHEN CUTTING PLASTICS, DO NOT ALLOW THE PLASTIC TO MELT. IF THE PLASTIC MELTS, IT CAN STICK TO THE BLADE, LEADING TO KICKBACK.**

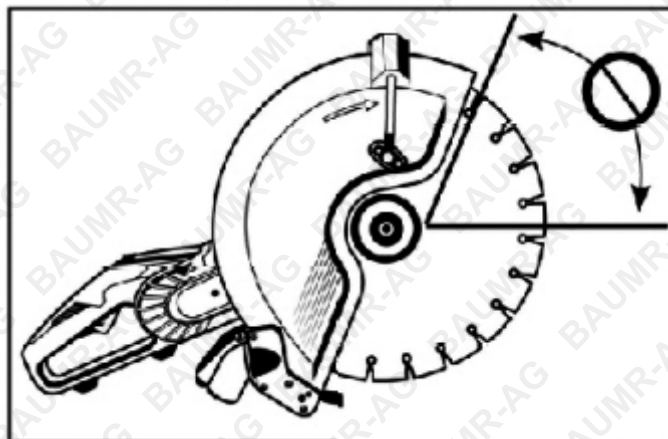
**Electrical Connection**

- The network voltage must conform to the voltage indicated on the tool name plate. Under no circumstances should the tool be used when the power supply cable is damaged. A damaged cable must be replaced immediately by an authorised Customer Service Centre. Do not try to repair the damaged cable yourself. The use of damaged power cables can lead to an electric shock.
- **WARNING: NEVER OPERATE A DAMAGED MACHINE. ALWAYS TAG A DAMAGED MACHINE AND TAKE IT OUT OF SERVICE UNTIL REPAIRS CAN BE MADE.**

- **WARNING:** THESE MACHINES ARE EQUIPPED WITH A PORTABLE RESIDUAL CURRENT DEVICE (PRCD) ALSO KNOWN U A GROUND FAULT CIRCUIT INTERRUPTER (GFCI). ALWAYS USE THIS DEVICE WHENEVER USING THE MACHINE TO REDUCE THE RISK OF SHOCK HAZARDS. ALWAYS POSITION THE PRCD AS CLOSE AS POSSIBLE TO THE POWER SOURCE. TEST AND RESET THE PRCD DEVICE BEFORE EACH USE. PRESS THE "TEST" BUTTON TO TEST. PRESS THE "RESET" BUTTON TO ENERGIZE THE CIRCUIT TO THE MACHINE.
- **WARNING:** ALWAYS CONNECT THE PLUG INTO THE WALL SOCKET WITH A DRIP LOOP. IF THE CABLE LEADS DOWNWARD DIRECTLY INTO THE WALL SOCKET, ANY WATER ON THE CABLE COULD RUN INTO THE SOCKET, CAUSING A HAZARD.

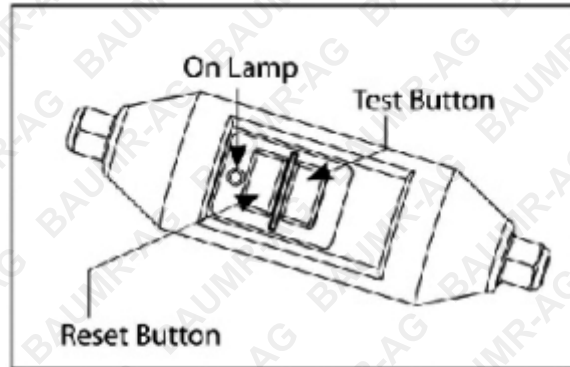

**Note:** PRCD (GFCI) appearances vary according to the requirements of various regions. Photos for reference only

**⚠ DANGER ⚠**

**Running combustion engines in confined areas CAN KILL IN MINUTES. Engine exhaust fumes contain carbon-monoxide – a deadly gas that you cannot smell or see.**



**NEVER run a combustion engine in confined areas EVEN IF windows and doors are open. ONLY run petrol engines OUTDOORS and away from doors, windows, and vents.**

Do not operate the equipment in hazardous locations, such as where there may be a risk of fire or explosions from flammable liquids, gases, or dust.

Do not operate the equipment in confined areas where exhaust gases, smoke or fumes could reach dangerous concentrations.

Do not refuel a combustion engine while it is running on or hot.

Never smoke while refuelling combustion engines or handling flammable substances.





















For generators, the electrical output is potentially lethal and must only be connected to a fixed electrical installation by an appropriately licensed person.















Be aware that the equipment may include hazardous components, such as blades, hot surfaces and moving parts.

Handle any flammable substance with extreme caution.

# Safety Symbols

The product may have safety warning labels attached to it, explained below. Understand the symbols on your product and their meanings. If any stickers become unreadable, unattached etc., replace them.

 <p><b>Flammable Material Hazard</b> Flammable liquids, gases, or substances etc may present. Avoid ignition sources and open flames. Danger of fire.</p>	 <p><b>Read User Manual</b> Read and fully understand product safety warnings, operation, procedures etc before using the product.</p>	 <p><b>Use Hand Protection</b> Wear appropriate hand protection and take due care as the product or use of the product may present hand hazards.</p>	 <p><b>Carbon-Monoxide Hazard</b> Do not use the product in confined areas or without adequate ventilation. Carbon-monoxide poisoning can be fatal.</p>
 <p><b>Electrocution / Electrical Shock Hazard</b> High voltage or high current electricity may be present or required by the product. Take due care when handling electrical products, cables, plugs and leads. Electrical shock can be fatal.</p>	 <p><b>Toxic Fumes / Dust Hazard</b> Using the product or by-products from use may produce fumes, smoke or particles that could be harmful if inhaled. Wear appropriate breathing protection and have adequate ventilation.</p>	 <p><b>Explosive Material Hazard</b> Combustible liquids, gases, or substances etc may be present. Avoid ignition sources and open flames. Danger of explosion.</p>	 <p><b>Cutting / Amputation Hazard</b> The product may have blades, edges or mechanical devices that can cause severe cut injury to fingers, limbs etc. Take due care when handling and using the product.</p>
 <p><b>Crush Hazard</b> The product may have blades, edges or mechanical devices that can cause severe crush injury to fingers, limbs etc. Take due care when handling and using the product.</p>	 <p><b>Single Operator Only</b> The product must be operated by a single person only. More than one person operating the product may introduce additional hazards.</p>	 <p><b>Use Face Protection</b> Wear appropriate full-face protection and take due care as the product or use of the product may present face and eye hazards.</p>	 <p><b>Use Foot Protection</b> Wear appropriate foot protection and take due care as the product or use of the product may present foot hazards.</p>
 <p><b>Use Eye / Ear / Head Protection</b> Wear appropriate eye and / or ear and / or head protection and take due care as the product or use of the product may present eye, hearing, and head hazards.</p>	 <p><b>Running Hazard</b> Do not run on or near the product as doing so may present a fall hazard.</p>	 <p><b>Diving Hazard</b> Do not dive into the product as doing so may present a neck / head injury hazard.</p>	 <p><b>Adult Supervision Required</b> Always supervise children and other users of a product to prevent drowning or injury.</p>
 <p><b>Skin Penetration / Puncture Hazard</b> The product may produce pressure, emit liquids or objects that can cause severe injury to fingers, limbs, blood etc. Take due care when handling and using the product.</p>	 <p><b>Hot Surface Hazard</b> Be aware that the product may produce high temperatures and hot surfaces that can cause burn injuries.</p>	 <p><b>Flying Debris Hazard</b> Be aware that the product or use of the product may present hazards produced by flying debris. Wear appropriate clothing and protective devices.</p>	 <p><b>Moving Parts Hazard</b> Be aware that the product contains or uses mechanical devices that move or rotate. Always wait for moving parts to stop fully before handling the product, adjusting, maintenance etc.</p>

 <p><b>Carbon-Monoxide Hazard</b> Do not use the product in confined areas or without adequate ventilation. Carbon-monoxide poisoning can be fatal.</p>	 <p><b>Pull Hazard</b> Be aware that the product contains or uses mechanical devices that can pull in objects and can cause severe injury to fingers, limbs etc. Take due care when handling and using the product.</p>	 <p><b>Slope / Fall Injury Hazard</b> Be aware that using the product on sloping surfaces or in slippery conditions may present additional dangers from falls and contact with blades, moving parts, hot surfaces etc.</p>	 <p><b>"Slam Dunk" Warning</b> Do NOT attempt "slam dunk" manoeuvres as this may result in severe injury due to falling, product breakage or collapse etc.</p>
 <p><b>Electrocution / Electrical Shock Hazard - Outdoor</b> High voltage or high current electricity may be present or required by the product. Do NOT use in rain, damp, or wet conditions. Electrical shock can be fatal.</p>	 <p><b>Electrocution / Electrical Shock Hazard - Disconnect</b> High voltage or high current electricity may be present or required by the product. Always disconnect the product from the electrical supply before handling the product, adjusting, maintenance etc.</p>	 <p><b>Power Line Electrocution Hazard</b> High voltage / high current power lines may be present. Use extreme caution to avoid contact or interference with power lines. Electrical shock can be fatal.</p>	 <p><b>"Kick-Back" Hazard</b> High level of "kick-back" hazard that can cause the machine to suddenly rotate towards operator. Kick-back injury can be fatal.</p>
 <p><b>Winch Operator Position Hazard</b> Do NOT stand between winch and load. Do NOT use winch to move people.</p>	 <p><b>Winch Lift Hazard</b> Do NOT LIFT load vertically. Use machine to PULL only.</p>	 <p><b>Cable Hazard</b> Ensure that load bearing cable is not kinked or knotted.</p>	 <p><b>Winch Cable Hazard</b> Ensure that there is a minimum number of cable coils on winching mechanism.</p>
 <p><b>Winch Hook Hazard</b> Carry hook to load – do NOT throw or run.</p>	 <p><b>Flash / Blinding Hazard</b> Wear appropriate eye protection for welding. Direct exposure to weld arcs may cause permanent eye injury.</p>	 <p><b>Laser Hazard</b> Laser may be in use – do NOT look directly at laser or allow others to.</p>	 <p><b>Choking Hazard</b> Children under 8 yrs. Can choke or suffocate on small parts. Adult supervision required.</p>

# Table of Contents

<b>Safety</b> .....	<b>2</b>
Safety Symbols .....	7
<b>Parts Identification</b> .....	<b>10</b>
<b>Assembly</b> .....	<b>12</b>
Blade Guard Brush .....	12
Splash Guard .....	12
Water Connection .....	12
Guide Roller Assembly .....	12
Flush Cutting Kit Instructions (Optional) .....	13
Overload & Load Warning Lamp .....	14
Overheat Thermal Protection .....	14
Connecting to Vacuum Cleaner .....	15
Installing or Removing the Wheel .....	15
<b>Operation</b> .....	<b>16</b>
Introduction .....	16
Adjusting the Depth of cut .....	16
Securing the Wheel Guard .....	16
Switch Action .....	17
General Operation .....	18
Understanding and Avoiding "Kick-Back" and Other Reactionary Forces .....	19
Basic Cutting Guidelines .....	20
Cutting Wheels and Discs .....	20
<b>Maintenance</b> .....	<b>22</b>
Dressing Diamond Wheel .....	22
Replacing Carbon Brushes .....	22
<b>Specifications</b> .....	<b>23</b>

# Parts Identification

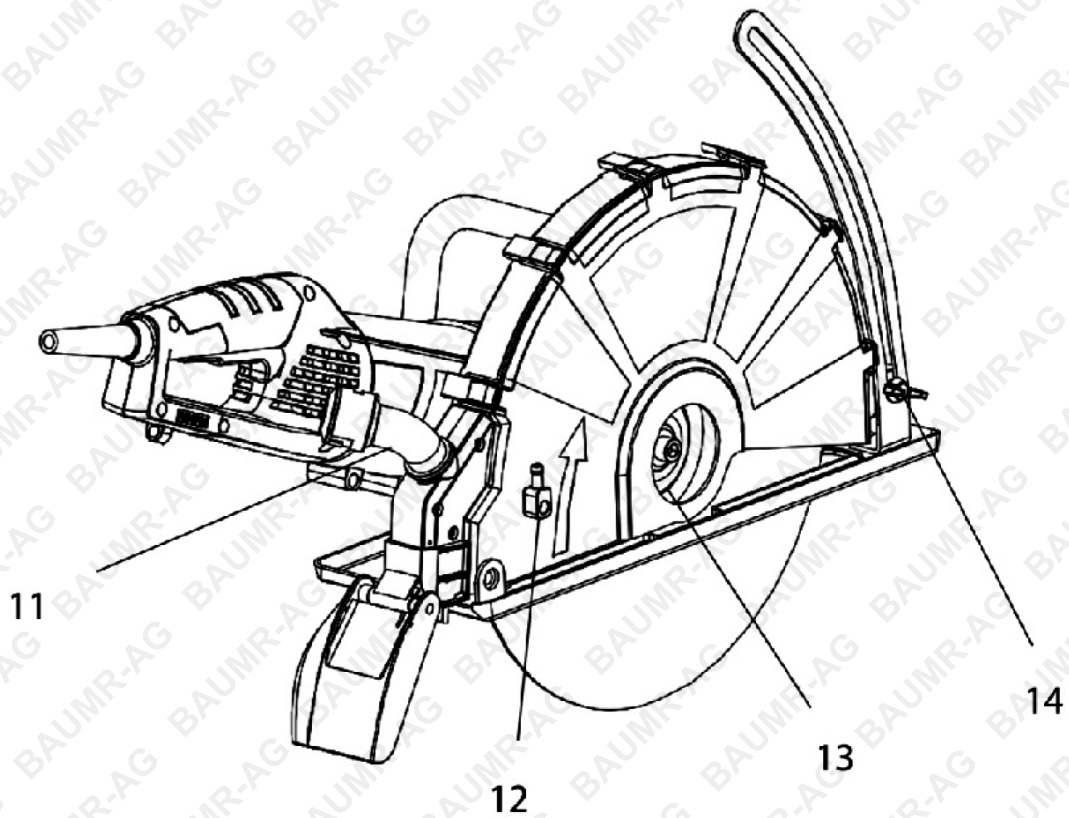
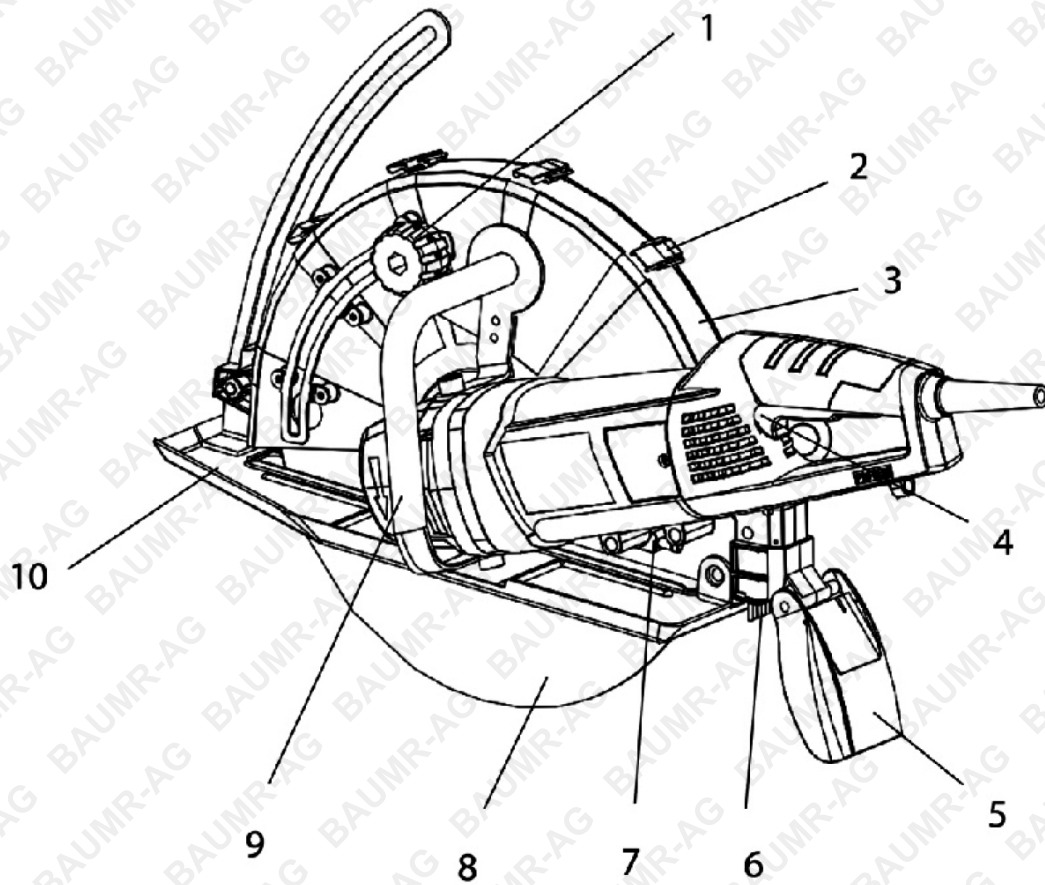

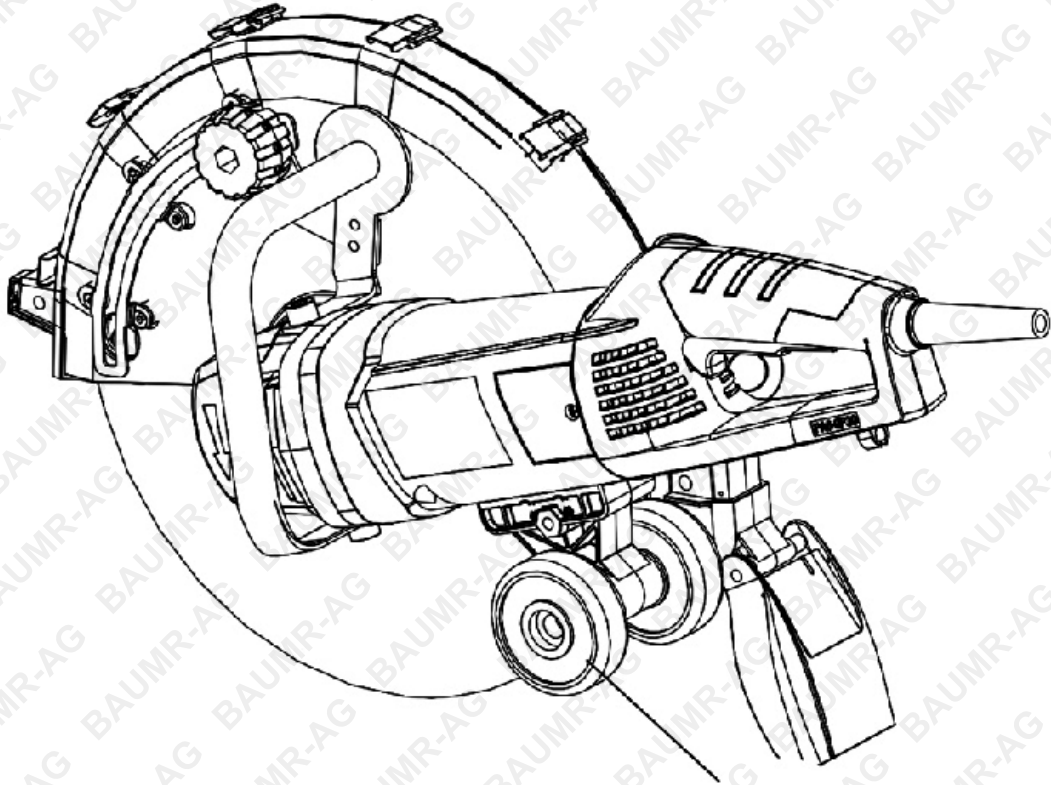

15



16

No.	Name	No.	Name
1	Clamping Nut	9	Anti-vibration Front handle
2	Toggle Latches	10	Base
3	Adjustable Wheel Guard	11	Vacuum port
4	Trigger Switch	12	Alternate Feed Nozzle 2
5	Splash Guard	13	Outer/Inner Flange
6	Blade Guard Brusv	14	Wing Bolt
7	Alternate Feed Nozzle 1	15	Gulde Roller
8	Saw Blade	16	Water Inlet

# Assembly

**CAUTION:** Always be sure that the tool is switched off and unplugged before carrying out any work on the tool.

## Blade Guard Brush

There is a removable brush at the rear of the guard to help contain sparks, dust, debris, and slurry. To install, simply push the brush into the slot in the bottom of the dust port bracket until it clicks in place. This brush may be pulled straight out to replace when worn.

## Splash Guard

The spring-loaded splash guard is useful to help to contain slurry which splashes toward the back. To install, simply clip into place on the back of the dust port bracket. To remove, tilt upward to pop free.

If the splash guard is not needed, such as when cutting dry, it may be clipped up out of the way. Simply engage the male clip on the flap with the female clip on the mount. Unclip to release.

## Water Connection

Water is a basic requirement for diamond sawing with wet-type diamond blades. The water serves as a coolant to avoid the working surface of the diamond segments from overheating.

When the diamond bit becomes overheated, both the bond matrix and even the diamonds break down, thus destroying the blade. Besides cooling, water also keeps down dust and flushes away abrasive particles.

**WARNING:** Always use the PRCD (GFCI) when operating with water **WARNING:** Never allow water to enter the motor. It could lead to an electric shock.

**WARNING:** Check all connections of the water feed system to ensure there are no leaks. Inspect hoses and other critical parts which could deteriorate.

**WARNING:** The maximum water pressure should not exceed 70psi [4 bar].

Use a water collector with a wet vacuum to collect cooling water if nearby objects could be damaged by water. The water feed system is built into the machine. To connect with the water supply, first pull the quick-release collar to remove the female side of the water coupling. Then unscrew the nut and engage the coupling to the water hose. Now reconnect the water coupling to the male water feed valve. Press it until it clicks.

The water flow is controlled by the water feed valve. The water to the blade may be finely adjusted to the required amount and no more.

**NOTE:** Contaminants in the water supply can easily plug up the fine water nozzles in the blade guard. Ensure that the supply water is clean. If you find that there is no water flow to the blade, then clean out the water feed system on the machine.

## Guide Roller Assembly

The guide rollers make it easier to keep the blade plane perpendicular to the workpiece. To install, slacken the butterfly bolt slightly and engage the four claws with the four eyelets on the bottom of the motor housing, then tighten the butterfly bolt. Note that roller assembly is offset to one side to avoid contacting the blade, so it may only be installed in one orientation.

If it is not needed, the guide roller assembly may be removed and set aside.

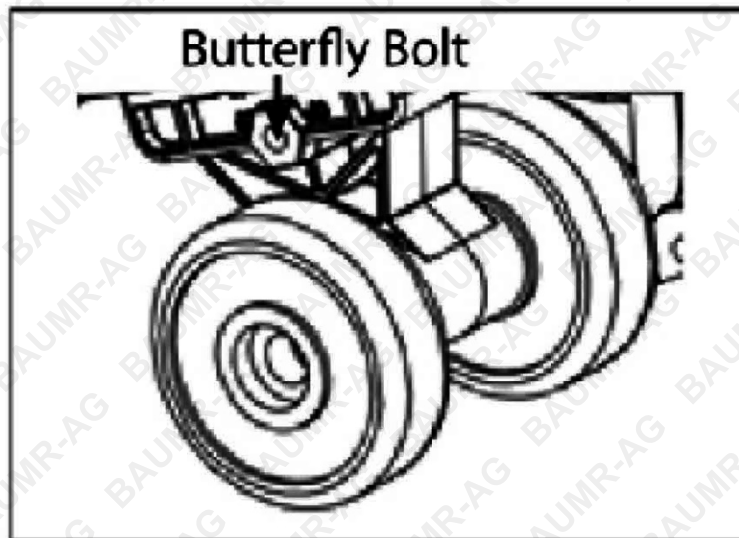

## Flush Cutting Kit Instructions (Optional)

The flush cutting kit enables a flush cut blade (not included) to be mounted to the machine which allows flush cuts to be made while the outer blade guard is temporarily removed. The flush cut blade may be left in place and the operator may return to standard cutting simply by replacing the outer blade guard and securing with the 4 toggle latches. In this way, it is quick and convenient to switch between standard and flush cutting mode. Or if desired, the flush cutting blade and flange may be removed, and the machine returned to the standard configuration.

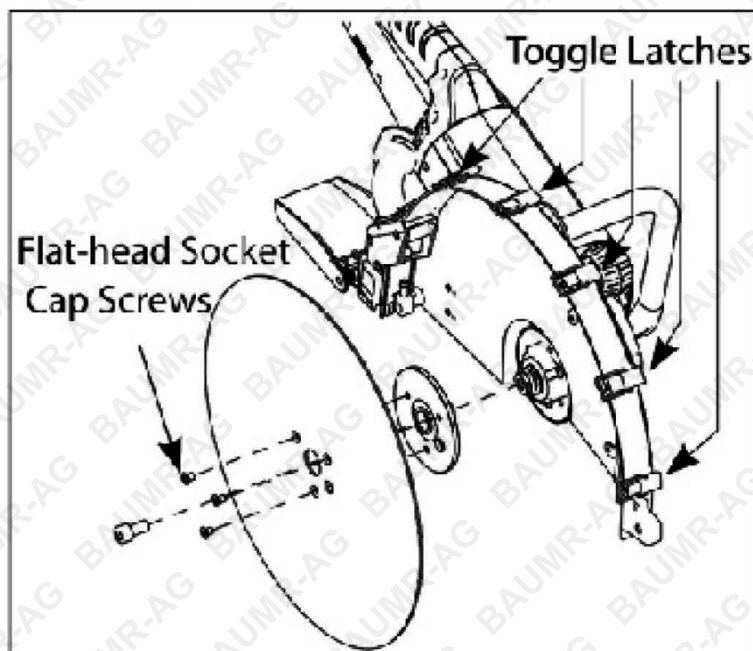

## Overload & Load Warning Lamp

When full load is reached, the load warning lamp will flash red. If full load is exceeded and sustained for too long, the motor will shut down and the load warning lamp will glow solid red. In this case, the motor must be first shut off and then restarted. When this happens, the motor will very likely be near overheating, so it is also a good idea to run the motor at no load for a few minutes to cool it before continuing.

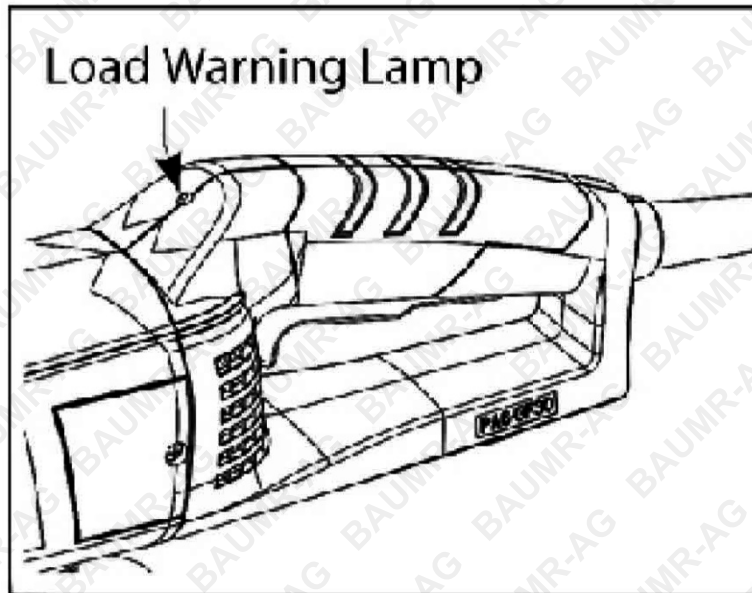

## Overheat Thermal Protection

If the temperature of the motor gets too high, the thermal protection will shut the motor down. The switch must be first shut off and then restarted. When this happens, do not immediately start cutting after restarting the motor. Always run the machine at no load for a few minutes to return to a normal operating temperature before continuing.

**CAUTION:** The motor will be damaged if it is repeatedly overloaded or overheated. Always cool the motor by running at no load for a few minutes whenever it stops from either overheat or overload.

## Connecting to Vacuum Cleaner

When you wish to perform cleaner operation, connect a vacuum cleaner to your tool. Connect a hose of vacuum cleaner to the dust nozzle via an elbow joint (accessory).

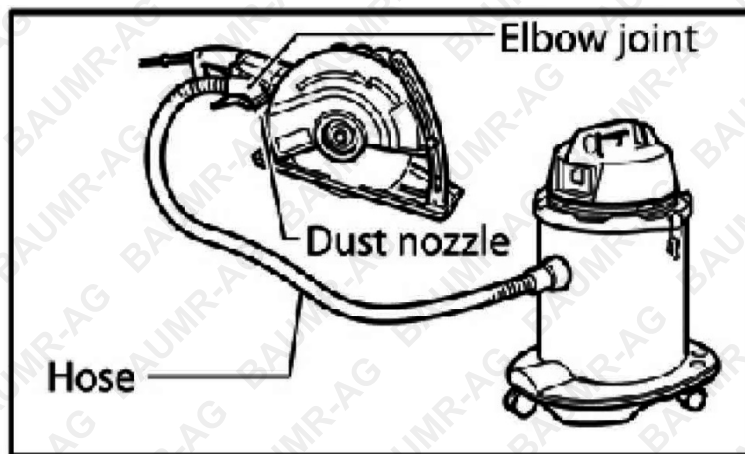

## Installing or Removing the Wheel

To remove the wheel, depress the shaft lock to hold the shaft stationary, then loosen the hex bolt clockwise with the socket wrench. To install a wheel, place flange with its partly elevated side facing the tool, and then place ring before installing a wheel onto the spindle (shaft) and another flange with partly elevated side facing outward. Be sure to fully tighten the hex bolt counterclockwise after mounting the new wheel, or operation will be dangerous.

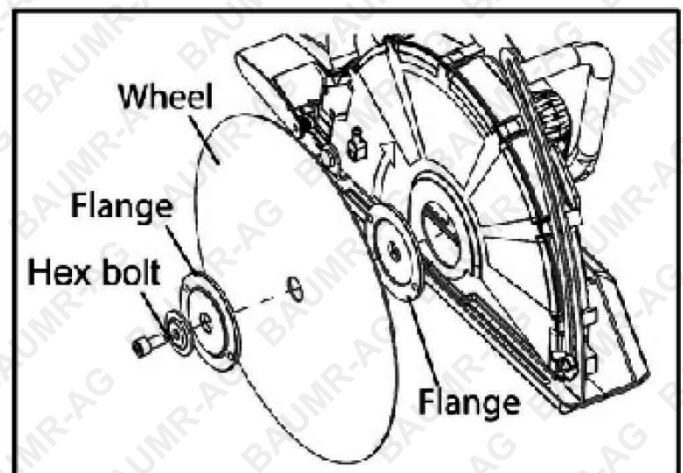
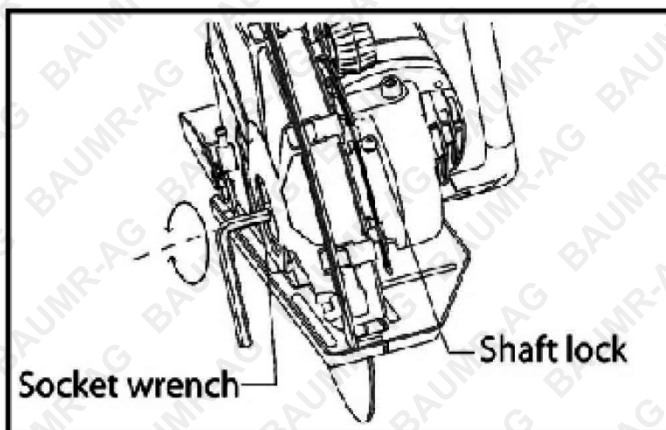

# Operation

## Introduction

This machine is equipped with two handles and a blade guard. The motor has overload and overheat protection. It has an integrated water feed system as required for diamond cutting and has a portable residual current device (PRCD) for electrical safety. It is used primarily with diamond blades, but abrasive wheels may also be used with this machine. It is intended for cutting masonry, stone, concrete, reinforced concrete and similar materials. All other uses are prohibited.

**CAUTION:** Always be sure that the tool is switched off and unplugged before adjusting or checking the function on the tool.

## Adjusting the Depth of cut

Loosen the wing bolt on the depth guide and move the base up or down. at the desired depth of cut, secure the base by tightening the wing bolt.

Only case you adjust the cutting depth to the maximum one, always be sure to do the adjustment after adjustment of the wheel guard.

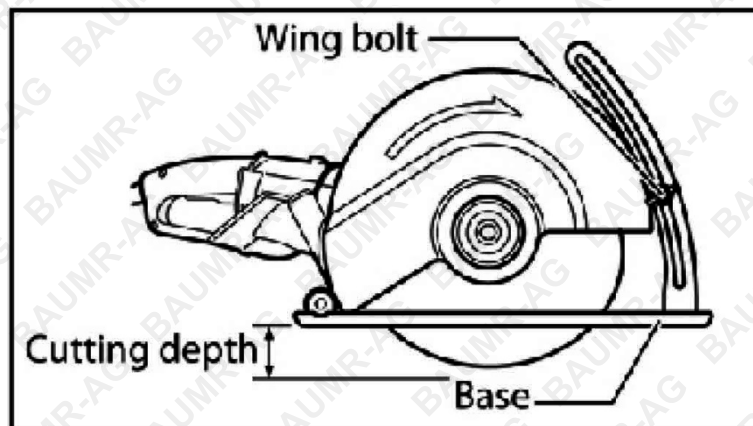

## Securing the Wheel Guard

**CAUTION:** The wheel guard must be adjusted on the tool so that the closed side of the guard always points toward the operator.

The wheel guard can be adjusted about 80 degrees, after you loosen the clamping nut. Adjust to the desired angle, then secure the clamping nut.

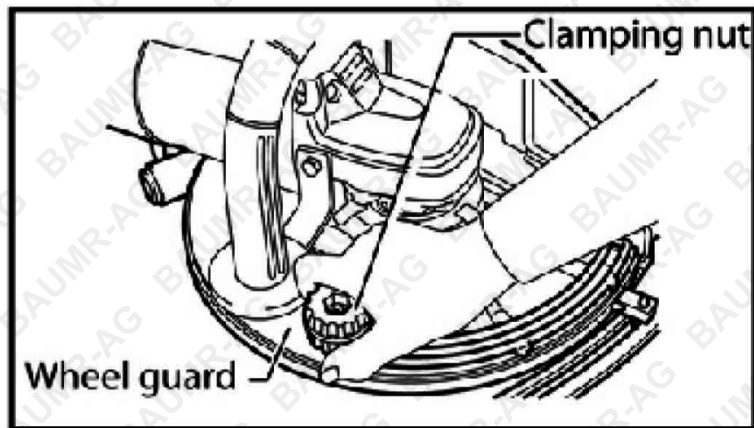

## Switch Action

**CAUTION:** Before plugging in the tool, always check to see that the switch trigger actuates properly and returns to the "OFF" position when released.

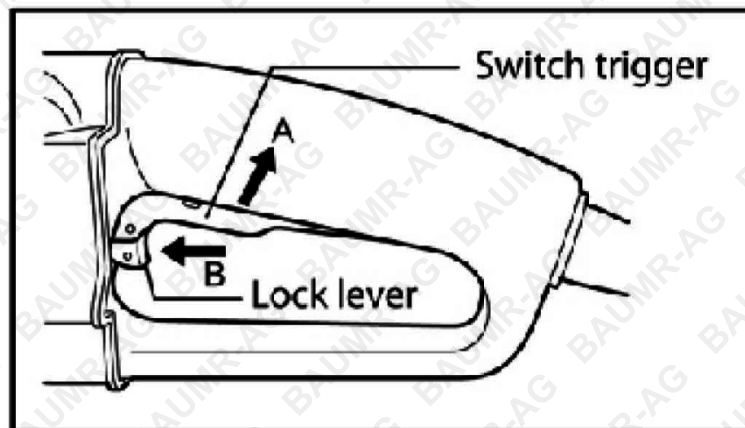

**CAUTION:** Switch can be locked in "ON" position for ease of operator comfort during extended use. Apply caution when locking tool in "ON" position and maintain firm grasp on tool.

- To start the tool, simply pull the switch trigger. (A direction) Release the switch trigger to stop.
- For continuous operation, pull the switch trigger (A direction), push in the lock lever (B direction) and then release the switch trigger.
- To stop the tool from the locked position, pull the switch trigger (A direction) fully, then release it.

**CAUTION:** Do not pull the switch trigger hard without pressing the lock lever. This can cause switch breakage. To prevent the switch trigger from accidentally pulled, a lock lever is provided.

1. To start the tool, push in the lock lever (in the B direction) and then pull the switch trigger (in the A direction).
2. Release the switch trigger to stop.

## General Operation

**CAUTION:** Be sure to pull the tool when cutting a workpiece. • This tool should only be used on horizontal surfaces. • Use this tool for straight line cutting only. Cutting curves can cause stress cracks or fragmentation of the diamond wheel and abrasive cut-off wheel resulting in possible injury to persons in the vicinity. • After operation, always switch off the tool and wait until the wheel has come to a complete stop before putting the tool down. • When cutting concrete blocks, tiles, or masonry materials, do not make a cut in depth more than 60 mm (2-3/8"). When you need to cut a workpiece over 60 mm (2-3/8") up to 100 mm (4"), make more than two passes of cuts. The depth of the most efficient cut is about 40 mm (1-9/16").

1. Hold the tool firmly with both hands. First keep the wheel without making any contact with a workpiece to be cut. Then turn the tool on and wait until the wheel attains full speed.
2. The cut is made by pulling the tool toward you (not by pushing away from you). Align the notch on the base with your cutting line when performing a cut.
3. Switch off the tool on the position posed when finishing a cut. Raise the tool after the wheel comes to a complete stop.

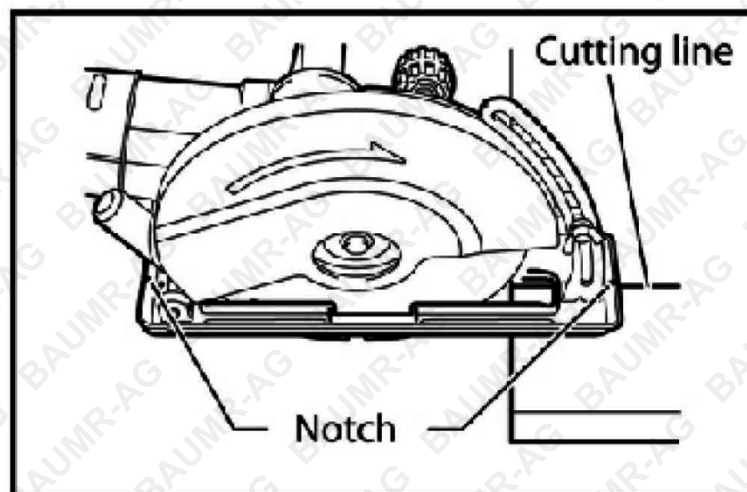

## Understanding and Avoiding "Kick-Back" and Other Reactionary Forces

**Kick-back and other reactionary forces can cause loss of control of the machine and can result in serious, even fatal injury – use the machine in ways to avoid kick-back and other reactive forces at all times.**

When the cutting wheel is rotating, many forces are created, such as the ability to cut. The contact point between the cutting wheel and object to cut is critical. If the saw is not used correctly, cutting forces may become "reactionary", in that instead of the cutting wheel rotating, a reactionary force is created. Many factors affect the occurrence and force of reaction, such as cutting speed, cut depth, and cutting wheel condition.



### Kick-Back

"Kick-back" is a reactionary force that causes the cutting wheel to rotate up and back, against the direction of cut. Kick-back can also be thought of as the cutting wheel "kick-back zone" "digging in" to the object to be cut and momentarily stopping or significantly slowing rotation of the cutting wheel, which causes the saw to suddenly and quickly rotate backwards towards the operator. To avoid kick-back:

- Do NOT use the tip of the cutting wheel for cutting or allow it to make contact with any object.
- Always hold the machine firmly by both front and rear handles when operating.
- Maintain cutting wheel sharpness and the correct cutter shape and cutting depth.
- Do NOT use the machine in any way where the machine cannot be securely held with both hands or the entire machine is not visible to the operator.
- Use extreme caution when inserting the saw into a previous cut.
- Be alert to forces that may pinch the cutting wheel.

## Pull-In

"Pull-in" is a reactionary force that causes the saw to pull forward in the direction of cut. Pull-in can also be thought of as the bottom of the cutting wheel being caught, pinched or "digging in" to the object to be cut and momentarily stopping or significantly slowing rotation of the cutting wheel, which causes the saw to suddenly and quickly pull forward and away from the operator. To avoid pull-in:

- Ensure that the position of the cut in relation to the workpiece avoids closing.
- Use supports to help prevent cuts closing in over the cutting wheel.

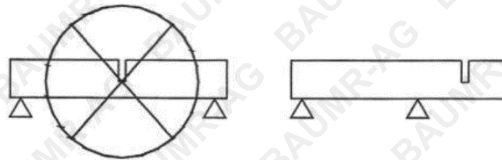

## Basic Cutting Guidelines

The following information are general guidelines to concrete saw use:

- Be alert to kick-back dangers at all times.
- Do NOT "plunge" cut or attempt deep, single-pass cuts.
- Keep the cutting guard as far forward (covering the cutting wheel) as practical.
- ALWAYS cut with the cutting wheel vertical (90° to the workpiece).
- Make small depth cuts, moving the saw back and forth through the cut, gradually increasing depth.

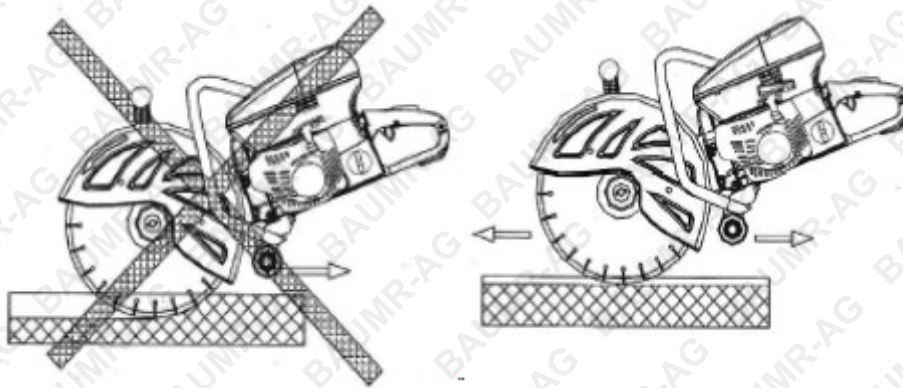
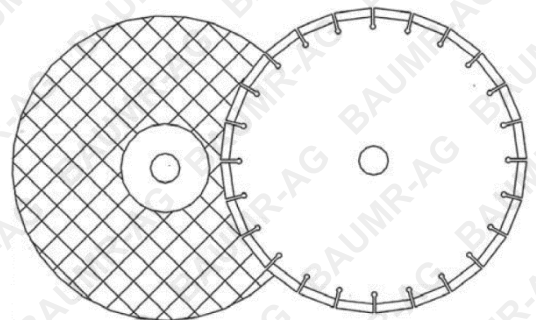

*Image for illustrative purposes*

## Cutting Wheels and Discs

There are 2 types of cutting wheels that can be used with the saw – synthetic resin abrasive disc, and diamond coated toothed steel.

- NEVER use a cutting wheel that has a slower speed rating than the saw (5100RPM / 90m/s).
- NEVER use a cutting wheel to cut material it is not designed to cut.
- Use only replacement blades recommended or supplied by the manufacturer.



## Abrasive Types

The cutting material in abrasive discs consists of abrasive grit bonded to the disc, which is generally made from a fiberglass material.

Cutting performance is determined by the type and size of the abrasive grit, and the type and hardness of the bonding agent. "Soft" cutting discs cut faster, however, also wear faster. "Hard" discs cut slower, but last longer.

- Do NOT use water cooling with abrasive cutting wheels.
- Do NOT allow synthetic resin cutting wheels to be exposed to water or moisture – they absorb moisture and can become unbalanced if any moisture is absorbed.
- Before using a cutting disc, check it carefully for damage, such as cracking or chipping. Place your finger through the spindle hole in the disc and lightly tap the outer edge of the disc with a piece of wood – the disc should "ring". If not, the disc may be damaged or unbalanced and should not be used.
- Abrasive discs cannot be "sharpened".

## Diamond Types

The cutting wheels use a steel platter that often features "teeth" cut into the outer edge. The outer edge and teeth have a diamond grit bonded to them that can be clearly seen. If the diamond edge can no longer be seen, the cutting wheel requires replacing.

Generally, diamond cutting wheels have a long service life if used properly and maintained. Water cooling is recommended at all times. If a water supply is not available, lift the wheel from the cut every 30 seconds and allow it to spin in the air for 10 seconds each time to cool.

- NEVER attempt to cut metals using diamond cutting wheels.
- Always check that the direction of rotation for the cutting wheel is the same as the saw.
- Always lubricate diamond cutting wheels with water during use. Connect the coolant tube to a suitable water supply and keep the cutting wheel lubricated.
- Do not use excessive downward pressure as this can lead to dulling of the cutting edges.
- Diamond cutters can be dulled by the metallic bond melting over the diamond grit. To "sharpen" a dulled cutting wheel, make several cuts into a piece of "diamond dressing stone", fire-brick or suitably abrasive material – this is to grind away the metallic bond and again expose the diamond grit.

## Maintenance

**CAUTION:** • Always be sure that the tool is switched off and unplugged before attempting to perform inspection or maintenance. • Never use gasoline, benzine, thinner, alcohol or the like. Discoloration, deformation, or cracks may result.

### Dressing Diamond Wheel

If the cutting action of the diamond wheel begins to diminish, use an old discarded coarse grit bench grinder wheel, or concrete block to dress the diamond wheel. To do this, tightly secure the bench grinder wheel or concrete block and cut in it.

### Replacing Carbon Brushes

- Use a screwdriver to remove the brush holder caps. Take out the worn carbon brushes, insert the new ones and secure the brush holder caps.
- To maintain product SAFETY and RELIABILITY, repairs, any other maintenance, or adjustment should be performed by Factory Service Centres, always using FACTORY replacement parts.

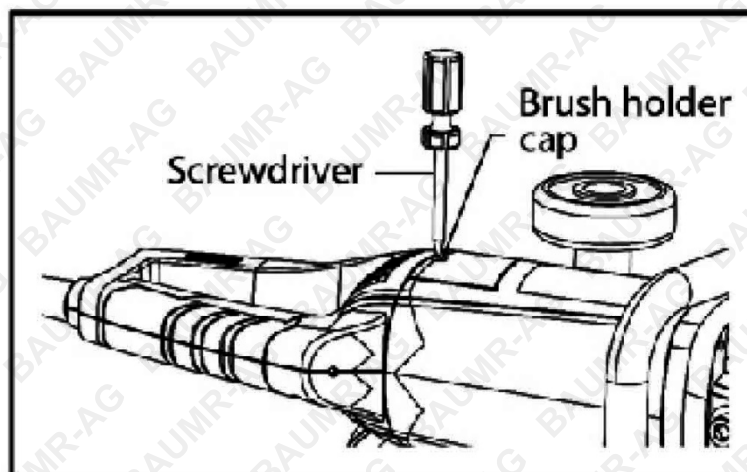

# Specifications

<b>Power (Watts)</b>	3500W
<b>Power Type</b>	Corded Electric
<b>Power RPM</b>	4000
<b>Blade Type</b>	Diamond
<b>Cutting Wheel size</b>	350mm (14")
<b>Cutting Depth</b>	115mm (Max)
<b>Power Plug</b>	15 Amp (SAA Approved)

*Important: Silica dust or respirable crystalline silica (RCS) is generated in workplace mechanical processes such as cutting natural stone or man-made products that contain silica. RCS can penetrate deep into the lungs and can cause irreversible lung damage. For more info see Safe Work Australia's info.*



**Some experts believe that the incorrect or prolonged use of almost any product may cause serious injury or death. To help reduce your risk of serious injury or death, refer to the information below. For more information, see [www.datastreamserver.com/safety](http://www.datastreamserver.com/safety)**

- Consult all documentation, packaging, and product labelling before use. Note that some products feature documentation available online. It is recommended to print and retain the documentation.
- Before each use, check the product for loose/broken/damaged/missing parts, wear, or leaks (if applicable). Never use a product with loose/broken/damaged/missing parts, wear, or leaks.
- Products must be inspected and serviced (if applicable) by a qualified technician every 6 months. This is based on average residential use by persons of average size and strength, and on a property of average metropolitan size. Use beyond these recommendations may require more frequent inspections/servicing.
- Ensure that all users of the product have completed a suitable industry recognised training course before being allowed access to the product.
- The product has been supplied by a general merchandise retailer that may not be familiar with your specific application or description of application. Be sure to attain third-party approval from a qualified specialist for your application before use, regardless of any assurances from the retailer or its representatives.
- This product is not intended for use where fail-safe operation is required. As with any product (for example, automobile, computer, toaster), there is the possibility of technical issues that may require the repair or replacement of parts, or the product itself. If the possibility of such failure and the associated time it may take to rectify could in any way inconvenience the user, business, or employee, or financially affect the user, business, or employee, then the product is not suitable for your requirements. This product is not intended for use where incorrect operation or a failure of any kind, including but not limited to, a condition requiring product return, replacement, parts replacement, or service by a technician may cause financial loss, loss of employee time or an inconvenience requiring compensation.
- If this product has been purchased in error when considering the information presented here, contact the retailer directly for details of their returns policy, if required.

