

St George

Australia 1947

Product Information

Product Code: Byron/ST-ZTT-250

*Seat Height (Floor to Top of Seat) :430mm

Product Size:684L x 398W X 507H

Set out:

S Trap: 140mm-260mm

P Trap: 180mm

Applicable Voltage : AC 220-240V/50Hz

Power : 1200W

Working Water Pressure: 250kpa - 500kpa

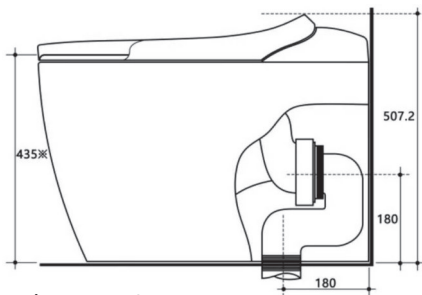

*Seat Height

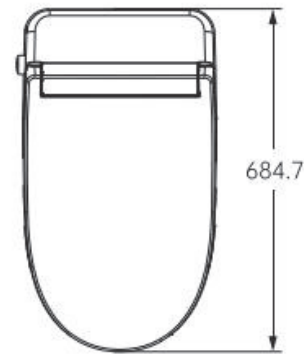

Feature:

Waterfilm™

-Pre-rinses the bowl surface to reduce stains and improve hygiene.

Verticoat™ Ceramic Shield

-An enhanced ultra-smooth glaze that minimizes surface friction, reducing build-up and maintaining a cleaner bowl with less effort.

Built-in Tank

-Integrated water tank ensures stable flushing even with low pressure.

Antibacterial Surface

-Special surface treatment helps inhibit bacterial growth.

Automatic Flush

-Hands-free automatic flushing for improved hygiene.

Rear Cleansing

-Comfortable rear wash with adjustable water pressure.

Front Cleansing

-Targeted front wash for enhanced personal cleanliness.

Water Pressure Control

-Adjustable water pressure to suit individual preferences.

Heated Seat

Night Light

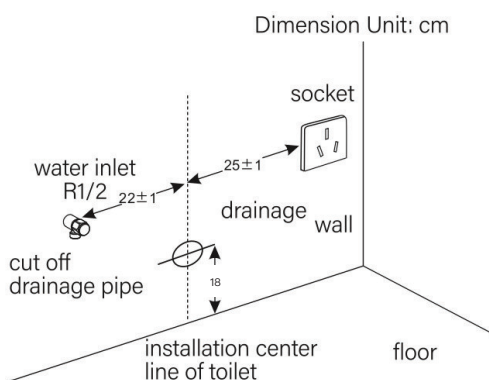

Remark: It is recommended to install water and electricity according to the dimensions shown in the diagram, otherwise it may cause the risk of pipe bending.

*Toilet complies with WMTS-051 and features an integrated Atmospheric Vacuum Breaker (AVB) that satisfies the high-hazard back-flow prevention criteria of AS/NZ 3500.1 without the use of an RPZ valve.

*Installation shall be in accordance with the AS/NZS 3500 series of standards.

*Portable water only. DO NOT USE seawater OR recycled water.

*Min water requirement 5L/ 15 second and water pressure at least 200 KPA stable. Maximum water pressure capacity 500 KPA.

*All rights reserved by Bravat Global Pty Ltd. Specifications and sizes are subject to change without notice

*Warranty: 3 years parts and labor for seat, 20 years ceramic pan.

