

# St George

Australia 1947

## Product Information

Product Code: Brighton/ST-ZTT-400

\*Seat Height (Floor to Top of Seat) :435mm

Product Size: 683L x 403W X 480H

Set out:

S Trap: 140mm-260mm

P Trap: 180mm

Applicable Voltage : AC 220-240V/50Hz

Power: 1200w

Working Water Pressure: 250kpa - 500kpa

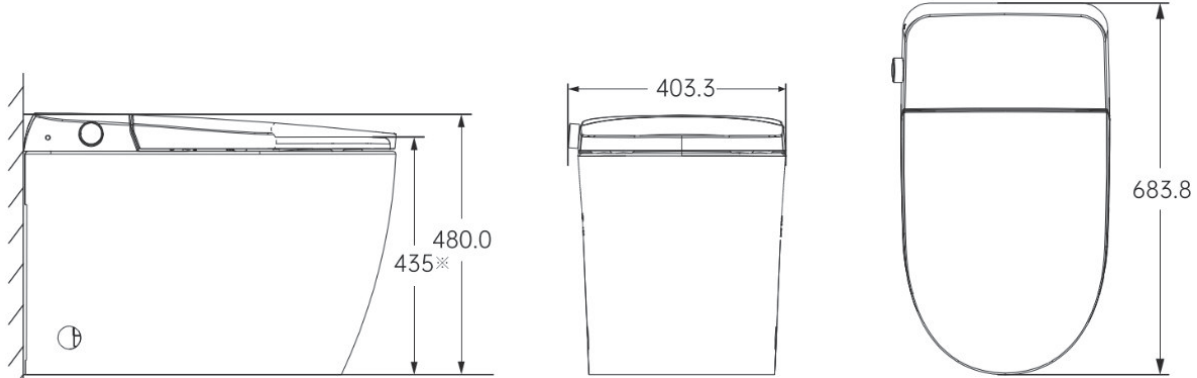

\*Seat Height



## Feature:

### Waterfilm™

–Pre-rinses the bowl surface to reduce stains and improve hygiene.

### Verticoat™ Ceramic Shield

–An enhanced ultra-smooth glaze that minimizes surface friction, reducing build-up and maintaining a cleaner bowl with less effort.

### Built-in Tank

–Integrated water tank ensures stable flushing even with low pressure.

### Antibacterial Surface

–Special surface treatment helps inhibit bacterial growth.

### Automatic Flush

–Hands-free automatic flushing for improved hygiene.

### Pulsating Cleansing

–Pulsating water spray for a massage-like cleansing effect.

### Female Soft Cleansing

### Deodorizer

–Automatic deodorising system keeps the bathroom fresh.

### Heater Seat

### Dryer

### Night Light

### Energy Saving

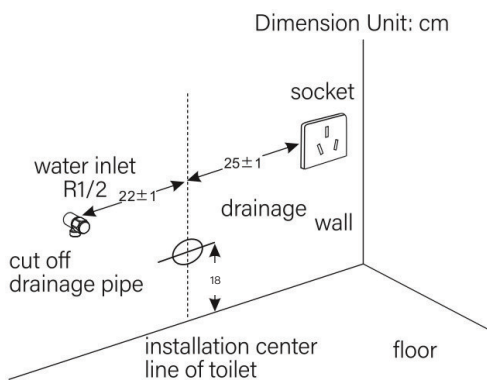

Remark: It is recommended to install water and electricity according to the dimensions shown in the diagram, otherwise it may cause the risk of pipe bending.

\*Toilet complies with WMTS-051 and features an integrated Atmospheric Vacuum Breaker (AVB) that satisfies the high-hazard back-flow prevention criteria of AS/NZ 3500.1 without the use of an RPZ valve.

\*Installation shall be in accordance with the AS/NZS 3500 series of standards.

\*Portable water only. DO NOT USE seawater OR recycled water.

\*Min water requirement 5L/ 15 second and water pressure at least 200 KPA stable. Maximum water pressure capacity 500 KPA.

\*All rights reserved by Bravat Global Pty Ltd. Specifications and sizes are subject to change without notice

\*Warranty: 3 years parts and labor for seat, 20 years ceramic pan.

