

# UNIMAC<sup>®</sup>

ACM-700c

**BELT DRIVEN  
OIL AIR COMPRESSOR**



## User Manual

[Revision 2.0]

READ THIS MANUAL CAREFULLY BEFORE USE – FAILURE TO DO SO MAY RESULT IN INJURY, PROPERTY DAMAGE AND MAY VOID WARRANTY. • KEEP THIS MANUAL FOR FUTURE REFERENCE. • Products covered by this manual may vary in appearance, assembly, inclusions, specifications, description, and packaging.

The product is NOT supplied with oil, although traces of oil from the manufacturing process may be present. It is essential to add adequate oil of the correct type before use. Failure to add oil will void the product warranty.

# Safety

Safety messages are designed to alert you to possible dangers or hazards that could cause death, injury or equipment or property damage if not understood or followed. Safety messages have the following symbols:



You **WILL** be **KILLED** or **SERIOUSLY INJURED** if you do not follow instructions.



You **CAN** be **KILLED** or **SERIOUSLY INJURED** if you do not follow instructions.



You **CAN** be **INJURED** if you do not follow instructions or equipment damage may occur.

It is vital that you read and understand this user manual before using the product, including safety warnings, and any assembly and operating instructions. Keep the manual for future reference.

Safety precautions and recommendations detailed here must be fully understood and followed to reduce the risk of injury, fire, explosion, electrical hazard, and/or property damage.

Safety information presented here is generic in nature – some advice may not be applicable to every product. The term "equipment" refers to the product, be it electrical mains powered, battery powered or combustion engine powered.

- **Before Use** - If you are not familiar with the safe operation/handling of the equipment or are in any way unsure of any aspect of suitability or correct use for your application, you should complete training conducted by a person or organization qualified in safe use and operation of this equipment, including fuel/electrical handling and safety.
- Do NOT operate the equipment in flammable or explosive environments, such as in the presence of flammable liquids, gases, or dust. The equipment may create sparks or heat that may ignite flammable substances.
- Keep clear of moving parts.
- Equipment may be a potential source of electric shock or injury if misused.
- Do NOT operate the equipment if it is damaged, malfunctioning or is in an excessively worn state.
- Do NOT allow others to use the equipment unless they have read this manual and are adequately trained.
- Keep packaging away from children - risk of suffocation! Operators must use the equipment correctly. When using the equipment, consider conditions and pay due care to persons and property.

## General Work Area Safety

- Work areas should be clean and well lit.
- Do not operate the equipment if bystanders, animals etc are within operating range of the equipment or the general work area.
- If devices are provided for connecting dust extraction / collection facilities, ensure these are connected and used properly. Dust collection can reduce dust-related hazards.

## General Personal Safety

- Wear appropriate protective equipment when operating, servicing, or when in the operating area of the equipment to help protect from eye and ear injury, poisoning, burns, cutting and crush injuries. Protective equipment such as safety goggles, respirators, non-slip safety footwear, hard hat, hearing protection etc should be used for appropriate equipment / conditions. Other people nearby should also wear appropriate personal protective equipment. Do not wear loose clothing or jewellery, which can be caught in moving parts. Keep hair and clothing away from the equipment.
- Stay alert and use common sense when operating the equipment. Do not over-reach. Always maintain secure footing and balance.
- Do not use the equipment if tired or under the influence of drugs, alcohol, or medication.
- This equipment is not intended for use by persons with reduced physical, sensory, or mental capabilities.

## General Fuel Safety

- Petrol/fuel/gasoline is extremely flammable – keep clear of naked flames or other ignition sources.
- Do not spill fuel. If you spill fuel, wipe it off the equipment immediately – if fuel gets on your clothing, change clothing.
- Do NOT smoke near fuel or when refuelling.
- Always shut off the engine before refuelling.
- Do NOT refuel a hot engine.
- Open the fuel cap carefully to allow any pressure build-up in the tank to release slowly.
- Always refuel in well-ventilated areas.
- Always check for fuel leakage. If fuel leakage is found, do not start, or run the engine until all leaks are fixed.

## General Carbon-Monoxide Safety

- Using a combustion engine indoors **CAN KILL IN MINUTES**. Engine exhaust contains carbon-monoxide – a poison you cannot smell or see.
- Use combustion engines **OUTSIDE** only, and far away from windows, doors, and vents.

## General Equipment Use and Care

- Keep packaging away from children and pets, potential risk of suffocation or choking.
- The equipment is designed for domestic use only.
- Handle the equipment safely and carefully.
- Before use, inspect the equipment for misalignment or binding of moving parts, loose components, damage, or any other condition that may affect its operation. If damaged, have the equipment repaired by an authorised service centre or technician before use.
- Prevent unintentional starting of the equipment - ensure equipment and power switches are in the OFF position before connecting or moving equipment. Do not carry equipment with hands or fingers touching any controls. Remove any tools or other items that are not a part of the equipment from it before starting or switching on.
- Do not force the equipment. Use the correct equipment for your application. Equipment will perform better and be safer when used within its design and usage parameters.
- Use the equipment and accessories etc. in accordance with these instructions, considering working conditions and the work to be performed. Using the equipment for operations different from those intended could result in hazardous situations.
- Always keep equipment components (engines, hoses, handles, controls, frames, housings, guards etc) and accessories (cutting tools, nozzles, bits etc) properly maintained. Keep the equipment clean and, where applicable, properly lubricated.
- Store the equipment out of reach of children or untrained persons. To avoid burns or fire hazards, let the equipment cool completely before transporting or storing. Never place or store the equipment near flammable materials, combustible gases, or liquids etc.
- The equipment is not weather-proof, and should not be stored in direct sunlight, at high ambient temperatures or locations that are damp or humid.
- Do not clean equipment with solvents, flammable liquids, or harsh abrasives.
- For specific equipment safety use and care, see Equipment Safety.

**General Electrical Safety**

- Inspect electrical equipment, extension cords, power bars, and electrical fittings for damage or wear before each use. Repair or replace damaged equipment immediately.
- Ensure all power sources conform to equipment voltage requirements and are disconnected before connecting or disconnecting equipment.
- When wiring electrically powered equipment, follow all electrical and safety codes.
- Always use a Residual Current Device (RCD) (GFCI) / Earth Leakage Circuit Breaker / Safety Switch when operating this item (electrical items only).
- High voltage / high current power lines may be present. Use extreme caution to avoid contact or interference with power lines. Electrical shock can be fatal.

**General Electrical Safety**

- Electrically grounded equipment must have an approved cord and plug and be connected to a grounded electrical outlet.
- Do NOT bypass the ON/OFF switch and operate equipment by connecting and disconnecting the electrical cord.
- Do NOT use equipment that has exposed wiring, damaged switches, covers or guards.
- Do NOT use electrical equipment in wet conditions or in damp locations.
- Do NOT use electrical cords to lift, move or carry equipment.
- Do NOT coil or knot electrical cords, and ensure electrical cords are not trip hazards.

**General Service Information**

- The equipment must be serviced or repaired at authorised service centres by qualified personnel only.
- Replacement parts must be original equipment manufacturer (OEM) to ensure equipment safety is maintained.
- Do NOT attempt any maintenance or repair work not described in this manual.
- After use, the equipment and components may still be hot – allow the equipment to cool and disconnect spark plugs and/or electrical power sources and/or batteries from it before adjusting, changing accessories, or performing repair or maintenance.
- Do NOT adjust while the equipment is running.
- Perform service-related activities in suitable conditions, such as a workshop.
- Replace worn, damaged or missing warning/safety labels immediately.

**Child Choking Hazard!**



**• WARNING: CHOKING HAZARD - CHILDREN UNDER 8 YRS. CAN CHOKE OR SUFFOCATE ON SMALL PARTS. ADULT SUPERVISION REQUIRED.**

- Carefully inspect anything a baby or child could gain access to, including this product & packaging.
- Dangers include anything of a size that could become stuck or lodged in a baby or child's airway.
- Dangers include things like raw, hard fruit and vegetable pieces, large pieces of meat, bones or sausage skins, popcorn, nuts, hard lollies and corn chips, small magnets and batteries, coins, beads, marbles and small uninflated balloons, broken toys and smaller toys, buttons, keys, and coins. But there are also many more.
- Pay particular attention to accessories, nuts, bolts, screws, washers, caps, covers, loose parts, parts that could be removed or break off, pieces of packaging, staples, tape etc.
- In the case of any doubt, secure the item of concern in an appropriate manner, or completely remove the possibility of access by a baby or child.

**Air Compressor Safety**

- Understand all operating procedures, safety precautions and warnings before operation.
- Most accidents occur as a result of failure to observe basic safety rules and precautions.
- Accidents can often be avoided by recognising potentially hazardous situations before they occur.
- Hazards that can potentially cause injury or damage to the compressor are identified by warning labels on the compressor and in this manual.
- Never use the compressor in a manner or for purposes that it has not been designed for or recommended by the manufacturer.
- Recommendations are made specifically regarding the workplace in addition to what is provided in this manual.
- Note - Refer to recommended instructions and precautionary measures to facilitate maintenance and special procedures.
- Specialised Personnel - Refer to operations that should be carried out by authorised service agents only.
- Service & Spare Parts - Use only original spare parts from your dealer or authorised service agent. Failure to do so may void your warranty and/or cause damage to your compressor.
- Read the instruction manual prior to use, ensure all operators are trained and experienced in the operation of the compressor and have read the instruction manual.
- Learn how to operate all controls and how to stop the compressor in case of emergency.
- Before commencing any service, routine maintenance, or inspection, ensure that your compressor is turned off, the power supply is disconnected, and all pressure has been released from the tank.
- After all maintenance operations ensure that all components have been fitted correctly.
- Ensure compressor is assembled according to the manufacturer's instructions.
- Always wear correct safety gear when operating the compressor (hearing protection, safety glasses, dust masks).
- Do not wear loose clothing or jewellery and keep long hair tied back or in a hair net when operating compressor.
- Do not allow infants, animals or anyone who is not authorised by you to operate or be in the operating area of your compressor.
- Avoid electrocution! Never use your compressor if the electrical cord or electrical components are frayed or damaged in any manner. Inspect all cords regularly.
- Never spray paint in confined areas or near naked flames.
- Do not touch the cylinder heads, cooling fins and feed pipes during operation. They will be hot and may cause burns. Even when your compressor has been turned off these parts retain heat for some time.
- Do not leave flammable or plastic objects near your compressor.
- Never move your compressor with pressure still in the tank.

## ACM-700c Belt Driven Oil Air Compressor

- Seek assistance if required when moving compressor.
- Never direct pressurised air at any person or animal.
- Never allow any person to operate your compressor unless they have read and understand this manual.
- Keep hands and loose objects clear of moving parts.
- Never operate your compressor without air filters.
- Never operate your compressor without the correct guards on moving parts and covers on electrical components.
- Never tamper with or attempt to adjust the pressure safety valve or valves.
- Never connect to your compressor an airline or hose that cannot withstand the air flow rate and pressure that your compressor can deliver.

### Transport and Handling - Unpacking

- Your compressor will be packed on a wooden pallet with a cardboard cover or in a cardboard box. All packaging is marked showing the correct way up and the weight of the compressor. Always ensure that the compressor is the correct way up before unpacking.
- If you store your compressor before unpacking it, ensure it is kept in a dry place with a surrounding temperature between 0-35 degrees Celsius. If your compressor is stored for long periods, it is recommended that the oil be replaced prior to commissioning.
- Ensure to wear safety glasses when cutting packaging straps. After removing the cardboard cover or open the top of the box, lift it out of the box with adequate assistance (use a suitable mechanical lifting device if the compressor is too heavy, ensure the lifting device is operated by qualified personnel). Secure the wheels, vibration dampers and or rubber pads.
- Compressors with tanks exceeding 100 litres capacity can be awkward to handle. Ensure that you keep the compressor well balanced at all times.

### Disposal of Packaging

- We recommend that you retain the packaging material for at least the warranty period. If disposing the packaging, please do so in a correct manner that is friendly to the environment.

### Positioning

- Your compressor should be placed on a level surface. Inclines greater than 15 degrees will cause damage. Your compressor requires ventilation. Ensure that all flywheels, fans, and cooling grills are unobstructed by any obstacles that may prevent air flow. Ensure that your compressor is in an environment that has clean air with a surrounding temperature between 5 -30 degrees Celsius.

### Commissioning

All compressors are pretested prior to delivery. To ensure that your compressor performs to the level that it was designed to follow hereinafter instructions:

- Check the oil level; check through the sight glass on the side of the compressor's pump or use the crankcase dipstick. Oil should be up to MAX level.
- After the first 50 hours of running replace the oil.
- Check the label on the electric motor and ensure that your mains power supply is adequate and correct. Mains power should be provided through a plug that is connected via fuses and an earth connection.
- Single phase models are supplied with a 10amp or 15amp three pin plug. The plug wall socket or power point should not be used as an ON/OFF switch.
- Check that the drain plug on the underside of the tank is closed.

### Operation Warnings

Before attempting to operate this compressor, the following basic safety precautions should always be taken to reduce the risk of fire, electric shock, and personal injury. It is important to read the instruction manual to understand the application, limitations and potential hazards associated with any tool. They are designed for the safety of yourself and others, ensuring a long and trouble-free service life from your machine.

#### WORK AREA

- Workbenches should be kept tidy because cluttered benches and work areas invite accidents. Floors should be kept clean and free from rubbish. Special care should be taken if the floor is slippery due to sawdust or wax.

#### WORK ENVIRONMENT

- Keep the work area well lit. Do not use compressor in areas where there is a risk of explosion or fire from combustible materials, flammable liquids, e.g., paint, varnish, petrol etc or flammable gases and dust of an explosive nature.

#### GUARD AGAINST ELECTRIC SHOCK

- Do not expose your compressor to rain or use in damp or wet locations.

#### BEWARE CHILDREN AND PETS

- Children and pets should be kept out of the work area.

#### USE THE RIGHT TOOL

- Select the right tool for the job. Do not use a tool for a job for which it was not designed. Do not force a small tool to do the job of a heavy-duty tool.

#### PERSONAL SAFETY CLOTHING

- Do not wear loose clothing, jewellery or anything that could get caught in moving machinery.

#### HAIR

- Long hair should be tied back or contained in a protective covering.

## ACM-700c Belt Driven Oil Air Compressor

### EYE PROTECTION

- Always use protective safety goggles or safety glasses.

### EAR PROTECTION

- Ear protection is advised during periods of extended operation.

### FOOTWEAR

- Where there is a risk of heavy objects damaging feet or if there is a risk of slipping on wet or slippery floors suitable non-slip safety footwear should be worn.

### SECURE THE WORK PIECE

- Wherever possible secure the work piece using clamps or a vice. It is safer than using your hand and leaves both hands free to control the air tool.

### DO NOT OVER-REACH

- Do not over-reach, keep proper footing and maintain your balance at all times.

### MAINTAIN TOOLS WITH CARE

- Keep cutting tools sharp and clean for better and safer performance. Follow the instructions for lubricating and changing accessories. Check the tool power cord periodically and if damaged have it replaced by an authorized service facility. Keep handles dry, clean and free from oil and grease. Ensure that ventilation slots are kept clean and free from dust at all times. Blocked ventilation slots can cause overheating and damage to the motor.

### STAY ALERT

- Watch what you are doing, use common sense, and do not operate the air tool when you are tired or have taken medication that causes drowsiness, consumed alcohol or drugs.

## General Warnings for Compressors

- Do not attempt to modify the compressor in any way.
- The use of any tools or accessory other than those designed for use with compressed air could result in injury to the operator.
- The output pressure of the compressor should be adjusted to the design pressure of the air tool or accessory being used.
- Always check that the output of the compressor does not exceed the maximum pressure for any attached tool or accessory.
- Repairs should only be carried out by qualified persons using original spare parts. Failure to do so may result in considerable danger to the user.

### BREATHABLE AIR WARNING

- This compressor/pump is not equipped for and should not be used to supply breathing quality air for any application of air for human consumption.

### OVERLOAD PROTECTION

- This compressor is fitted with an overload protection device. In the event that the motor becomes too hot, a thermal protection device will cut the mains supply to the motor. When the motor temperature returns to normal the mains supply will be restored automatically.

### EXTENSION CORDS AND REELS

- In general, it is not recommended to use an extension lead. A longer airline is recommended as voltage drop on extension leads may lead to motor damage and will void warranty. If an extension cord must be used, for lengths up to 5 metres, an approved 10 amp rated cord must be used.

### DO NOT ABUSE THE POWER CORD

- Never yank or pull on the power cord to disconnect it from the mains supply socket.
- Never carry or drag your compressor by its power cord. Keep the power cord away from heat, oil, solvents and sharp edges. If the power cord becomes damaged, have it replaced by an authorized service facility.

### CHECK FOR DAMAGED PARTS

- Before using the compressor, it should be carefully checked to determine that it will operate properly and perform its intended function. Check for the correct alignment of moving parts ensuring they do not bind. Check for broken or missing parts and have them replaced or repaired at an authorized service centre.
- Check any other condition that may affect the operation of the compressor. A guard or any other part of the compressor that is damaged should be properly repaired or replaced by an authorized service centre.

### DISCONNECT COMPRESSOR

- Ensure that the compressor is disconnected from the mains supply and the tank is empty when not in use, before servicing, lubricating, or making adjustments to air lines, and when changing accessories such as blades, bits, nails and cutters on air tools.

### AVOID UNINTENTIONAL STARTING





















- Ensure that the switch is in the OFF position before plugging the compressor into the mains supply.













### TURNING THE COMPRESSOR ON AND OFF

- Use the red knob on top of the pressure switch to turn the unit on and off. Pull the knob up to turn the compressor on and push the knob in to turn it off. Turning the unit on and off from the mains supply only will result in damage to the motor and void warranty as the pressure switch has an additional function to purge the air trapped in the delivery pipe when the motor is turned off. This minimises the load on the motor when it is next started.

# Safety Symbols

The product may have safety warning labels attached to it, explained below. Understand the symbols on your product and their meanings. If any stickers become unreadable, unattached etc., replace them.

 <p><b>Flammable Material Hazard</b> Flammable liquids, gases, or substances etc may present. Avoid ignition sources and open flames. Danger of fire.</p>	 <p><b>Read User Manual</b> Read and fully understand product safety warnings, operation, procedures etc before using the product.</p>	 <p><b>Use Hand Protection</b> Wear appropriate hand protection and take due care as the product or use of the product may present hand hazards.</p>	 <p><b>Carbon-Monoxide Hazard</b> Do not use the product in confined areas or without adequate ventilation. Carbon-monoxide poisoning can be fatal.</p>
 <p><b>Electrocution / Electrical Shock Hazard</b> High voltage or high current electricity may be present or required by the product. Take due care when handling electrical products, cables, plugs and leads. Electrical shock can be fatal.</p>	 <p><b>Toxic Fumes / Dust Hazard</b> Using the product or by-products from use may produce fumes, smoke or particles that could be harmful if inhaled. Wear appropriate breathing protection and have adequate ventilation.</p>	 <p><b>Explosive Material Hazard</b> Combustible liquids, gases, or substances etc may be present. Avoid ignition sources and open flames. Danger of explosion.</p>	 <p><b>Cutting / Amputation Hazard</b> The product may have blades, edges or mechanical devices that can cause severe cut injury to fingers, limbs etc. Take due care when handling and using the product.</p>
 <p><b>Crush Hazard</b> The product may have blades, edges or mechanical devices that can cause severe crush injury to fingers, limbs etc. Take due care when handling and using the product.</p>	 <p><b>Single Operator Only</b> The product must be operated by a single person only. More than one person operating the product may introduce additional hazards.</p>	 <p><b>Use Face Protection</b> Wear appropriate full-face protection and take due care as the product or use of the product may present face and eye hazards.</p>	 <p><b>Use Foot Protection</b> Wear appropriate foot protection and take due care as the product or use of the product may present foot hazards.</p>
 <p><b>Use Eye / Ear / Head Protection</b> Wear appropriate eye and / or ear and / or head protection and take due care as the product or use of the product may present eye, hearing, and head hazards.</p>	 <p><b>Running Hazard</b> Do not run on or near the product as doing so may present a fall hazard.</p>	 <p><b>Diving Hazard</b> Do not dive into the product as doing so may present a neck / head injury hazard.</p>	 <p><b>Adult Supervision Required</b> Always supervise children and other users of a product to prevent drowning or injury.</p>
 <p><b>Skin Penetration / Puncture Hazard</b> The product may produce pressure, emit liquids or objects that can cause severe injury to fingers, limbs, blood etc. Take due care when handling and using the product.</p>	 <p><b>Hot Surface Hazard</b> Be aware that the product may produce high temperatures and hot surfaces that can cause burn injuries.</p>	 <p><b>Flying Debris Hazard</b> Be aware that the product or use of the product may present hazards produced by flying debris. Wear appropriate clothing and protective devices.</p>	 <p><b>Moving Parts Hazard</b> Be aware that the product contains or uses mechanical devices that move or rotate. Always wait for moving parts to stop fully before handling the product, adjusting, maintenance etc.</p>

 <p><b>Carbon-Monoxide Hazard</b> Do not use the product in confined areas or without adequate ventilation. Carbon-monoxide poisoning can be fatal.</p>	 <p><b>Pull Hazard</b> Be aware that the product contains or uses mechanical devices that can pull in objects and can cause severe injury to fingers, limbs etc. Take due care when handling and using the product.</p>	 <p><b>Slope / Fall Injury Hazard</b> Be aware that using the product on sloping surfaces or in slippery conditions may present additional dangers from falls and contact with blades, moving parts, hot surfaces etc.</p>	 <p><b>"Slam Dunk" Warning</b> Do NOT attempt "slam dunk" manoeuvres as this may result in severe injury due to falling, product breakage or collapse etc.</p>
 <p><b>Electrocution / Electrical Shock Hazard - Outdoor</b> High voltage or high current electricity may be present or required by the product. Do NOT use in rain, damp, or wet conditions. Electrical shock can be fatal.</p>	 <p><b>Electrocution / Electrical Shock Hazard - Disconnect</b> High voltage or high current electricity may be present or required by the product. Always disconnect the product from the electrical supply before handling the product, adjusting, maintenance etc.</p>	 <p><b>Power Line Electrocution Hazard</b> High voltage / high current power lines may be present. Use extreme caution to avoid contact or interference with power lines. Electrical shock can be fatal.</p>	 <p><b>"Kick-Back" Hazard</b> High level of "kick-back" hazard that can cause the machine to suddenly rotate towards operator. Kick-back injury can be fatal.</p>
 <p><b>Winch Operator Position Hazard</b> Do NOT stand between winch and load. Do NOT use winch to move people.</p>	 <p><b>Winch Lift Hazard</b> Do NOT LIFT load vertically. Use machine to PULL only.</p>	 <p><b>Cable Hazard</b> Ensure that load bearing cable is not kinked or knotted.</p>	 <p><b>Winch Cable Hazard</b> Ensure that there is a minimum number of cable coils on winching mechanism.</p>
 <p><b>Winch Hook Hazard</b> Carry hook to load – do NOT throw or run.</p>	 <p><b>Flash / Blinding Hazard</b> Wear appropriate eye protection for welding. Direct exposure to weld arcs may cause permanent eye injury.</p>	 <p><b>Laser Hazard</b> Laser may be in use – do NOT look directly at laser or allow others to.</p>	 <p><b>Choking Hazard</b> Children under 8 yrs. Can choke or suffocate on small parts. Adult supervision required.</p>



# Table of Contents

<b>Safety</b> .....	<b>2</b>
Safety Symbols .....	6
<b>Parts Identification</b> .....	<b>9</b>
Compressor .....	9
BH65 Pump Head .....	11
<b>Preparations Before Use</b> .....	<b>13</b>
<b>Operation</b> .....	<b>14</b>
Designed Usage .....	14
Starting .....	14
Stopping .....	14
Overload Cut Out .....	15
How to Adjust Working Pressure .....	15
Pneumatic Connections .....	15
<b>Maintenance</b> .....	<b>16</b>
First 50 Working Hours .....	16
Weekly Operations .....	17
Check Oil .....	17
Drain Tank .....	17
Monthly Operations .....	18
Every 6 Months .....	18
Check Oil .....	18
General Cleaning .....	19
Check Belt Tension .....	20
Operations to be Carried Out Every 2 Years .....	20
Valve Check .....	20
Maintenance Table .....	21
Recommended Oils .....	21
<b>Troubleshooting</b> .....	<b>22</b>
<b>Specifications</b> .....	<b>23</b>

# Parts Identification

## Compressor

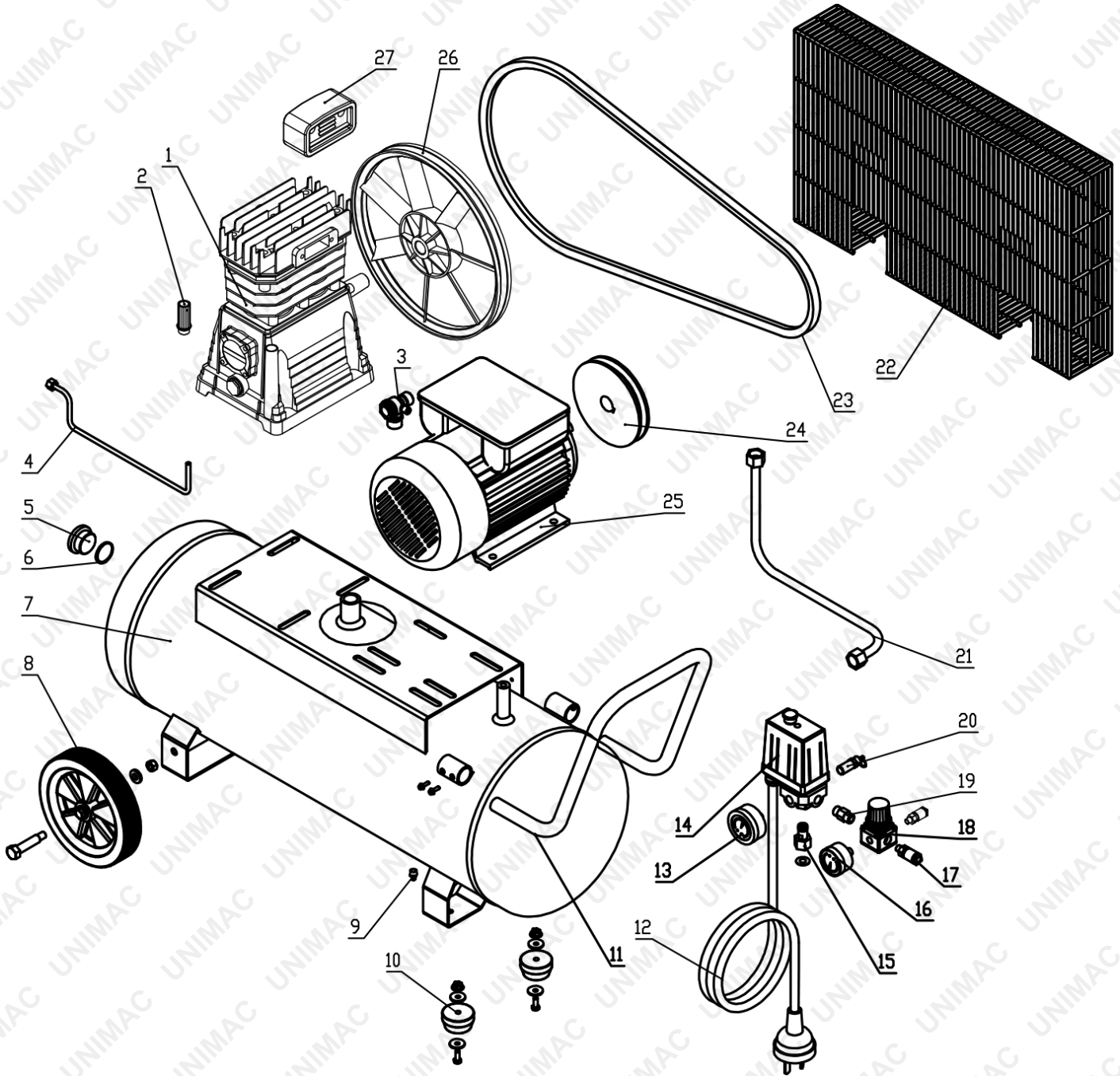

No	Description	Unit	Qty
1	BH65 pump Head	SET	1
2	Oil breather	SET	1
3	Check Valve	SET	1
4	Release pipe	PC	1

ACM-700c Belt Driven Oil Air Compressor

No	Description	Unit	Qty
5	Tank Plug	PC	1
6	O-ring for tank	PC	1
7	Tank	PC	1
8	Wheel	SET	2
9	Drain Valve	SET	1
10	Foot pad	SET	2
11	Handle	PC	1
12	Power Cord	PC	1
13	Pressure Gauge 50	PC	1
14	Pressure Switch	PC	1
15	PS Connector	SET	1
16	Pressure Gauge 40	PC	1
17	Quick coupler	PC	2
18	Regulator	SET	1
19	1/4 Connector	PC	1
20	Safety Valve	SET	1
21	Discharge Pipe	PC	1
22	Belt cover	SET	1
23	Belt	PC	1
24	Motor Pully	PC	1
25	Motor	PC	1
26	Pump pully	SET	1
27	Air Filter	PC	1
28	Capacitor Start (not shown)	PC	1
29	Capacitor Run (not shown)	PC	1

# BH65 Pump Head

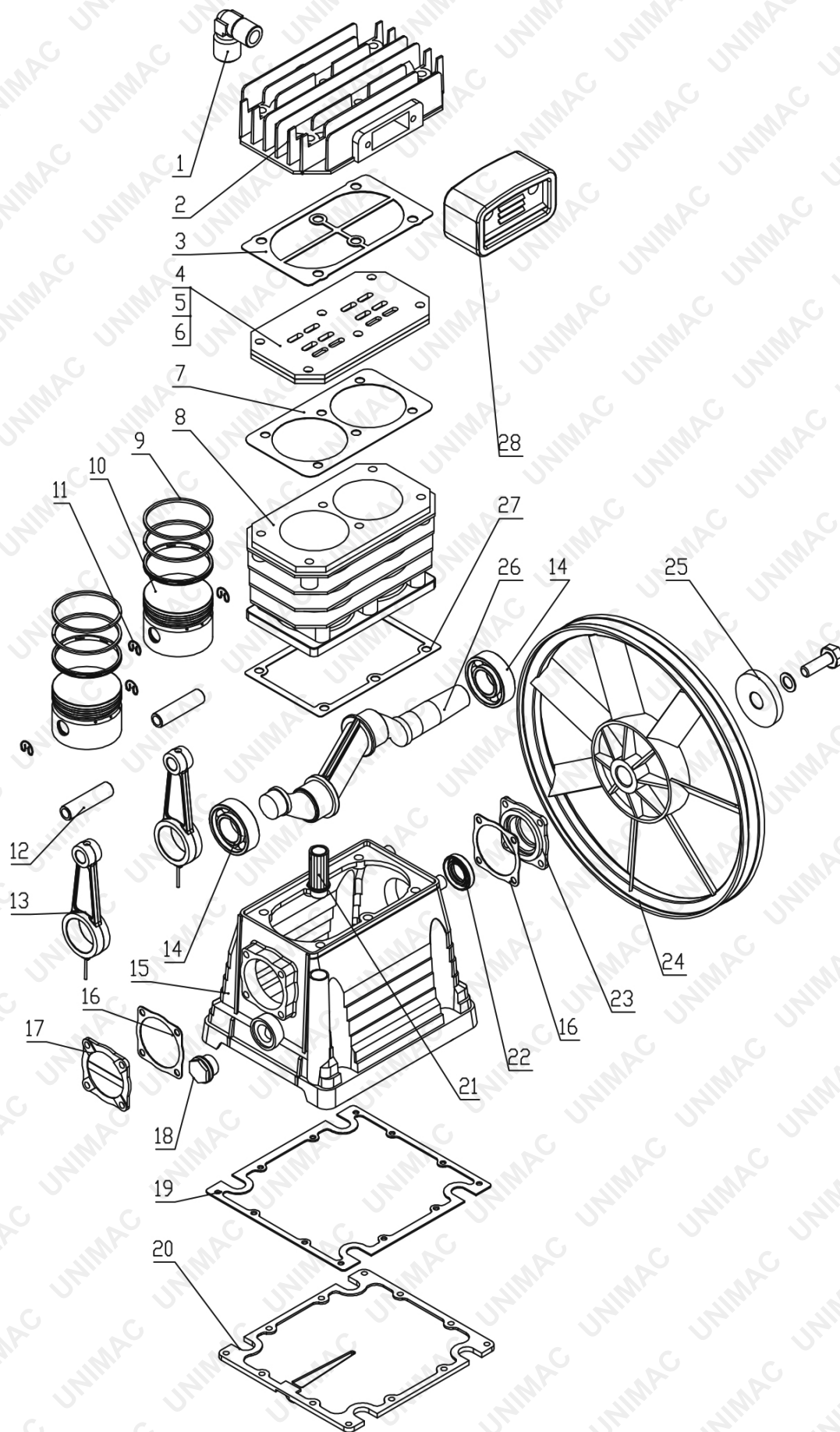

No	Description	Unit	Qty
1	Elbow Connector	PC	1
2	Cylinder head	PC	1
3	Cylinder head gasket	PC	1
4	Valve Plate	SET	1
5	Valve Slice	SET	1
6	Copper Seal	PC	1
7	Valve Gasket	PC	1
8	Cylinder	PC	1
9	Piston Ring 65	Set	2
10	Piston 65	PC	2
11	Hole Clip	PC	4
12	Piston Pin	PC	2
13	Connect rod	PC	2
14	Bearing 6205	PC	2
15	Crankcase	PC	1
16	Crank Cover Gasket	PC	2
17	Crank Cover	PC	2
18	Oil Glass	SET	2
19	Bottom Seal	PC	1
20	Bottom Plate	PC	1
21	Oil Breather	PC	1
22	Oil Seal	PC	1
23	Bearing Support	PC	1
24	Pump Pully	PC	1
25	Pully Blocker	PC	1
26	Crank Shaft	PC	1
27	Cylinder Seal	PC	1
28	Air Filter	SET	1

## Preparations Before Use

Before using your Compressor, follow these steps:

1. Remove all packing materials and any protective plastic bags, zip-tie labels or tags from the compressor cylinder head or oil plug.
2. Be sure the air filter is attached to the cylinder head.
3. Make sure the drain valve under the air tank is closed.
4. **ADD OIL TO THE CRANKCASE.** Oil has NOT been supplied in your air compressor. The oil level should be in the centre of the oil sight gauge on the pump. Use proper compressor oil only. See figure 1.
5. Connect to the power supply using the chord provided. Do not use and extension lead.

**NOTE: The machine should never be run without the correct level of oil in the sump of the pump. The oil provides lubrication to the cylinder rings which deliver the compressed air. Severe damage to the internal moving parts can occur if there is not adequate oil flow. Check the oil level frequently and change the oil on a regular schedule.**

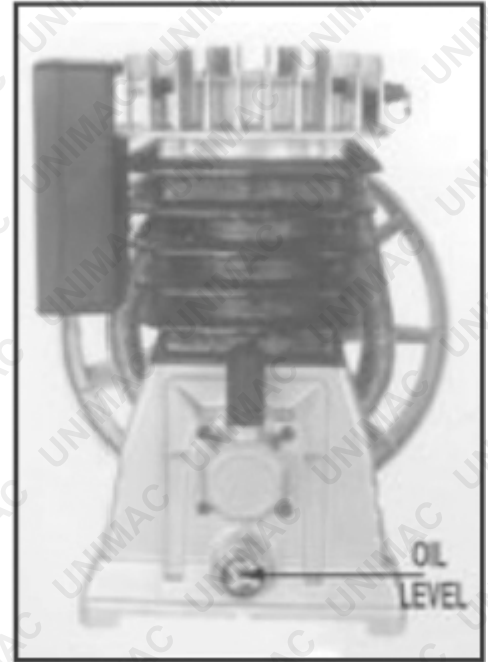

Fig.1 Oil level indicator

# Operation

## Designed Usage

Your compressor is designed to operate a variety of pneumatic tools & equipment. Such tools require different air volumes and pressures to operate correctly. Technical data of pneumatic tools and equipment should be provided by the manufacturer. Your dealer will assist you in making the correct choice or give you the correct advice if you are uncertain. Compressor pumps are designed for intermittent duty applications.

It is recommended that your compressor duty cycle never exceed 50%. This means that for a given time period such as a working day, your compressor should not operate for more than half of that time. It is also recommended that within that time period your compressor should not run continuously for more than 15 minutes.

Leaking air lines or poor installation may cause your compressor to run excessively. Always check for leaks. Your compressor should be switched off when unattended or not in use.

## Starting

After completing the installation, your compressor is ready to work.

1. Make sure the main switch is in position "OFF" (Fig. 2). Plug in the equipment.
2. Start up the compressor by turning the pressure switch Fig. 2 to position "ON" (Fig. 2).
3. When starting the compressor for the first time, leave it running for about 10 minutes with air cocks (A) completely open (Fig. 3).
4. After 10 minutes, close cock (A) and make sure that pressure in the tank is properly delivered. The compressor stops automatically when the max pressure is reached as shown on the gauge (B).

**NOTE: The pressure switch (C) (Fig. 2) stops the motor at Fig. 3 the max pressure setting and makes the compressor start again when pressure goes below the minimum threshold (i.e. about 2 bar less than the max pressure).**

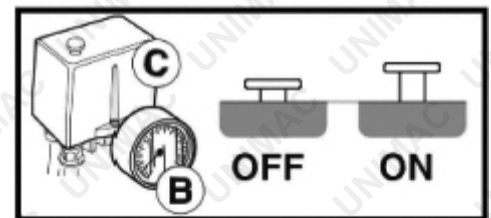

Fig. 2

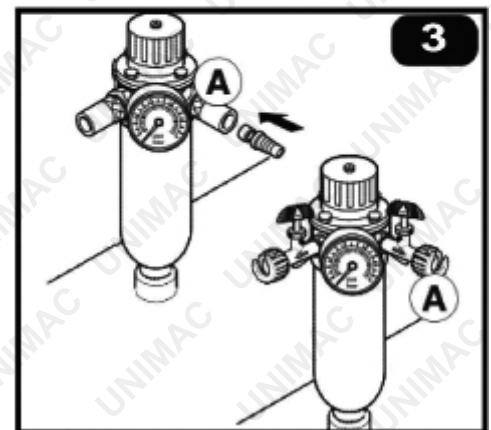

Fig. 3

## Stopping

Never stop the compressor by unplugging it; rather turn OFF the switch located on the pressure switch (Fig. 2). The compressed air inside the compressor head will flow out and will make the re-start easier.

When the compressor runs correctly, you should note if:

1. A whistle of compressed air whenever the motor stops,
2. A protracted whistle (about 20-30 seconds) whenever you start the compressor with no pressure in the tank (single-phase model). If either of these occur, then there is an air leak. Operating the compressor with an air leak will overwork the motor because it will keep running until the max pressure is reached. Overworking the motor will cause early failure and voids warranty.

## Overload Cut Out

SINGLE-PHASE compressors are equipped with an overload cut out (E) (Fig. 4) which operates as a safety device to protect the motor. When the motor overheats because of any fault arisen, the overload cut out automatically releases and cuts off power, thus preventing motor from being damaged. Wait a few minutes (about 5) before resetting the device, then start working again. If you restart the compressor and the overload cut out releases again, turn the main switch to position "0" OFF, unplug the equipment, and contact the place of purchase.

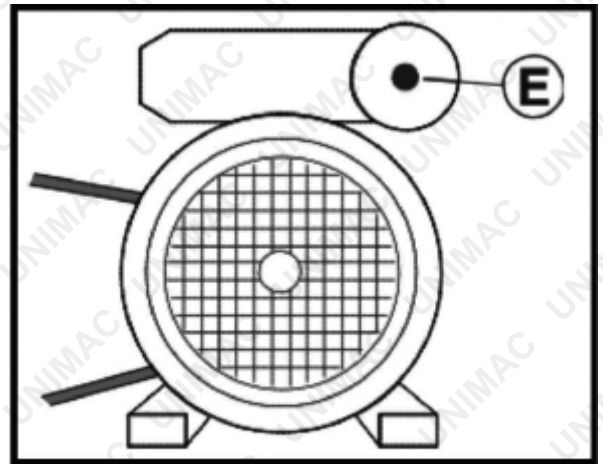

Fig. 4

## How to Adjust Working Pressure

To use all accessories at their best, see the manual for the rated pressure value need for the accessory you are going to use.

1. Use of the pressure reducer (D) to adjust delivery compressed air pressure.
2. Turn the knob clockwise to increase pressure and anticlockwise to reduce it. The pressure setting will appear on the gauge (E).
3. After having used your compressor, set pressure to zero, to avoid damaging the pressure reducer.

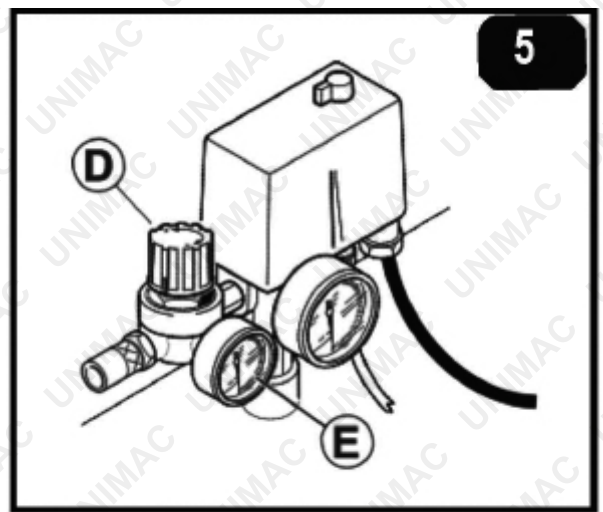

Fig. 5

## Pneumatic Connections

Always use air pipe, hose couplings and fittings that are designed to withstand the maximum pressure that your compressor can deliver. If you are unsure check with your dealer. Never repair faulty pneumatic connections.

# Maintenance

**ATTENTION:** Surface corrosion will occur on metal surfaces over time and the rate of oxidation depends on factors such as proximity to the ocean and humidity or condensation of water vapour on metal surfaces. To mitigate this, WD40 can be used to remove surface corrosion then, when applied periodically, it will prevent rust from forming.

**WARNING!** In order to keep your compressor in good working conditions we recommend you perform periodical servicing operations. Before performing any maintenance operation, switch off the compressor, remove the power supply and release all air in the tank.

## First 50 Working Hours

1. Ensure the compressor has been commissioned.
2. Check that all bolts are properly tight, paying special care to the head and crank case (Fig.6). Refer to the table below for recommended torque settings for cylinder head bolts.
3. Top up the compressor oil.

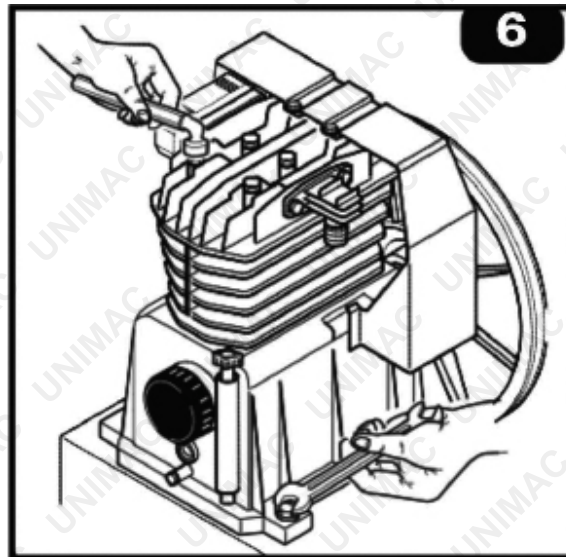

Fig. 6

### Torque Ranges for Tightening Head Bolts

Bolt Size	Min Torque	Max Torque
M8	22.45Nm	27.43Nm
M10	45.28Nm	55.34Nm
M12	77.10Nm	94.23Nm
M14	123.00Nm	150.37Nm

**WARNING! NEVER MIX DIFFERENT OILS TOGETHER!** Do not use non-detergent oils, recycled oil or low-quality oils as they have very poor lubricating properties.

**NOTE:** Do not pour oil down the drain. Contact your local council for correct disposal procedures.

## Weekly Operations

### Check Oil

Check the oil level and if necessary, top up. Do not exceed the mark corresponding to the max level (Fig. 7). Otherwise, make sure the oil does not drop below the minimum, to avoid any damage or seizure.

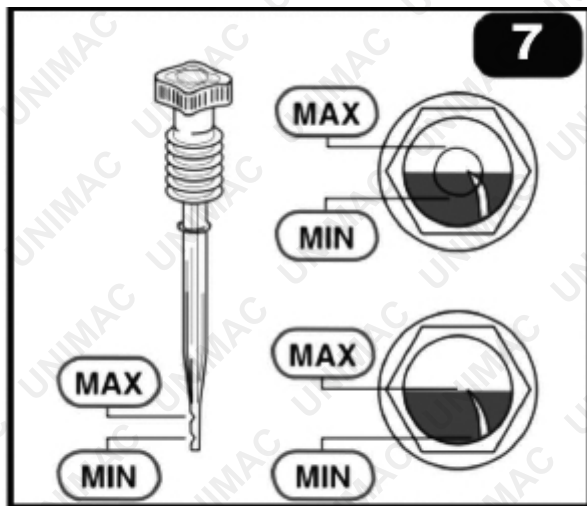

**Fig. 7**

### Drain Tank

Drain the tank condensation by opening the drain valve under the tank (Fig. 8), allow all the water to empty. Once empty, close the drain valve.

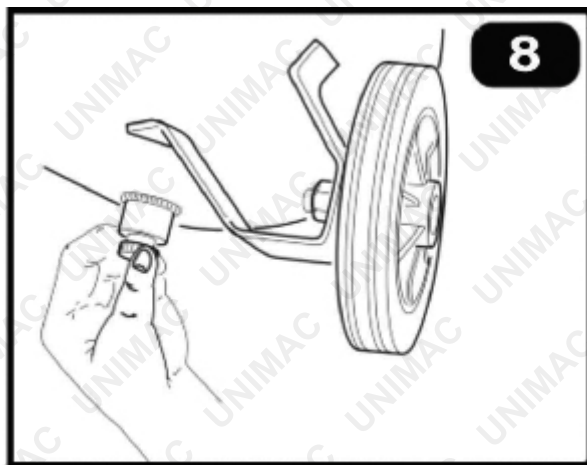

**Fig. 8**

## Monthly Operations

- Clean air intake (or more frequently, if the compressor operates in very dusty areas)
- Clean the Intake filter as follows (Fig. 9):
- Remove the air filter and clean or change the filter element as required.
- SPONGE ELEMENT: wash in a solution containing normal detergent, rinse and dry completely before refitting.

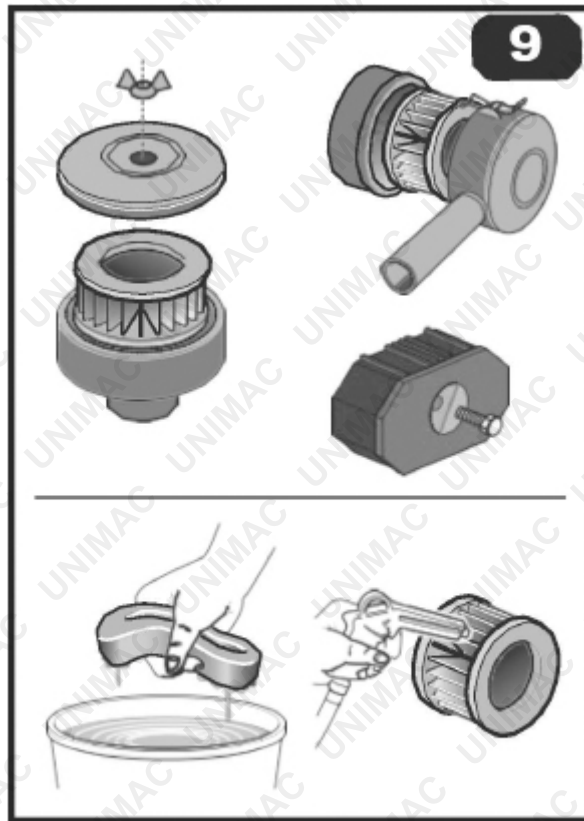

Fig. 9

**NOTE:** Appearance of air filter assembly may vary between models.

## Every 6 Months

### Check Oil

To change the oil, remove the dipstick/plug and unscrew the screw (A) (Fig.10), then collect the oil into a container. The oil change should be done when the compressor is hot, so the oil sump drains rapidly and completely. Once drained, replace the screw (A) in its housing and refill with fresh oil up to the max. level (for proper quantity, see the oil table enclosed to the instructions book).

**NOTE:** Do not pour oil down the drain. Contact your local council for correct disposal procedures.



Fig. 10

## General Cleaning

It is advisable to clean all the finned parts of your compressor to keep the cooling system efficient (Fig. 11). Wipe down the compressor using a damp cloth and air dry. Keeping the compressor clean ensures a long work life.

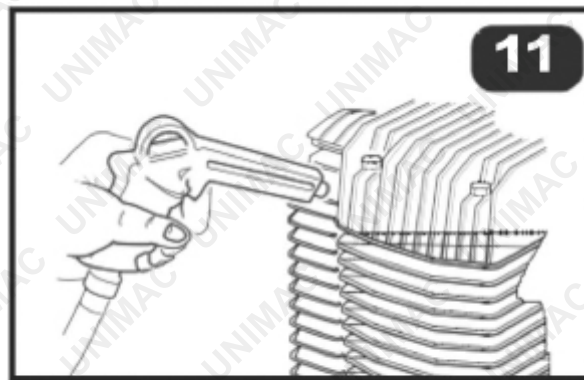

Fig. 11

## Check Belt Tension

Hang a weight of about 3 kg at the midpoint of the belt (fig. 12). The belt flexion should be about 10mm. If the belt flexion is more than 10mm, the belt needs to be tightened by adjusting the position of the motor. With the compressor off and unplugged, loosen the bolts holding the motor to the saddle and gently slide it further away from the pump. Re-tighten the bolts and check the tension.

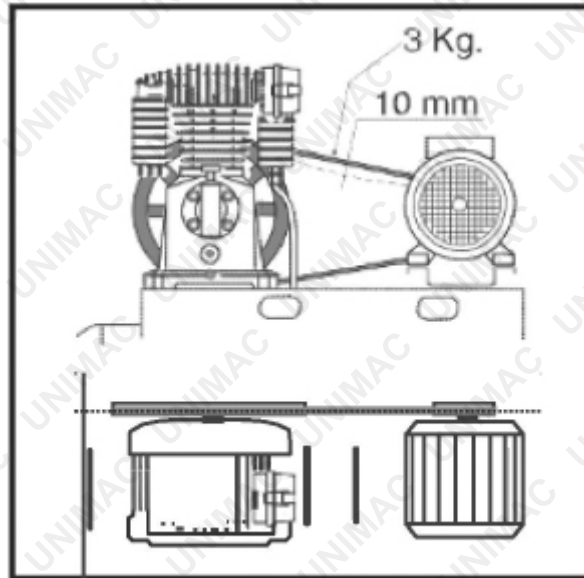

Fig. 12

**WARNING!** Take care not to disturb the pulley to flywheel adjustment. If there is still slack in the belt or it needs to be replaced, please contact the place of purchase.

## Operations to be Carried Out Every 2 Years

### Valve Check

Check the non-return valve and if necessary, replace the seal (D) (Fig. 13). Check intake and delivery valves.

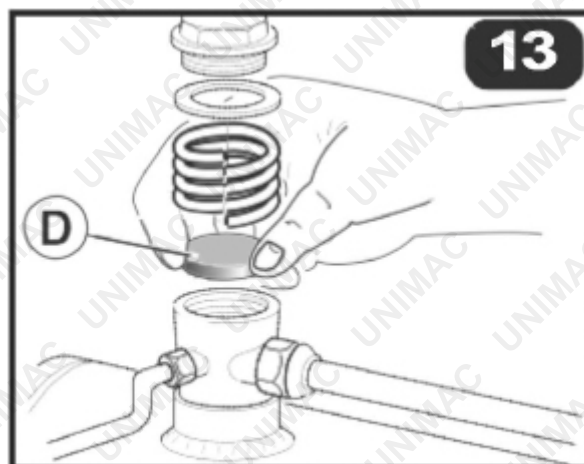

Fig. 13

## Maintenance Table

Maintenance Operations	Every Week	Every Month	6 Months	2 Years
Checking the Oil Level	✓			
Draining the Condensation	✓			
Cleaning the Intake Filter		✓		
General Cleaning of Compressor			✓	
Replacing the Oil			✓	
Check Belt Tension			✓	
Check/Cleaning Valves				✓

Standardised to DIN 51506 and ISO/DP6521.3

## Recommended Oils

- Room temperature below +5°C: ISO 68
- Room temperature above +6°C: ISO 100
- Room temperature above +25°C: ISO 150

AGIP	DICREA100	MOBIL	RARUS 427
BP	ENERGOL CS100	FINA	EOLAN AC 100
SHELL	COREMA OIL H10	CASTROL	AIRCOL PD100
ESSO	EXXC OLUB H150	TOTAL	CORTUSA 100
FUCHX	RENOLIN 104L VG 100	API	CM-8X
IP	CALATIA OIL ISO 100		

(Suitable for room temperature ranging from +5°C to +25°C)

# Troubleshooting

Fault	Cause	Remedy
<b>Pressure drops in the tank.</b>	Air leaks at connections	Make the compressor get to maximum pressure. Switch it off and brush a soapy water solution onto all connections. Look carefully for air bubbles flowing out. Tighten those connections where leaks are present.
<b>The pressure switch valve leaks when the compressor is idle.</b>	Non-return valve seal defective.	Make air in the tank flow out. Then remove the non-return valve plug and clean the seat. If necessary, replace the seal D, then mount again all components (Fig. 13).
<b>The pressure switch valve leaks when the compressor has been running for more than 1 minute.</b>	Failure of the empty-start valve.	Replace the valve.
<b>The compressor stopped and does not start.</b>	<ul style="list-style-type: none"> <li>▪ Overload cut out tripped (SINGLE-PHASE).</li> <li>▪ Heat relay tripped (THREE-PHASE)</li> <li>▪ Low oil level.</li> </ul>	Power off through the pressure switch, then press the restart button (fig. 4). If the overload cut out or the relay trip again, contact a specialised technician. Top up with oil.
<b>The compressor stopped and does not start.</b>	Winding burnt out.	Contact a specialised technician.
<b>The compressor does not stop even though the max pressure allowed has been reached; the safety valve operates.</b>	Wrong operation or pressure switch broken.	Contact a specialised technician.
<b>Compressor does not hold regular speed.</b>	Belt is slipping.	Tension up.
<b>The compressor does not get to the set pressure and overheats too much.</b>	Compressor head gasket broken or valve faulty.	Stop the compressor and contact a specialised technician.
<b>The compressor is noisy with metallic clangs.</b>	Bearing or bush seizure.	Stop the compressor and contact a specialised technician.

# Specifications

<b>Receiver Capacity</b>	70L
<b>Input Voltage</b>	240V
<b>Motor Input</b>	230~240V 50Hz
<b>Air Displacement</b>	280L/Min (9.9 CFM)
<b>Free Air Delivery</b>	200L/Min (7.0 CFM)
<b>Working Pressure</b>	116PSI (8bar)
<b>Restart Pressure</b>	86PSI (6bar)
<b>IP Rating</b>	IP20
<b>Power Rating</b>	2.2kW
<b>Power Plug</b>	Standard 10A (SAA Approved)

*Note: No assembly is required*



**Some experts believe that the incorrect or prolonged use of almost any product may cause serious injury or death. To help reduce your risk of serious injury or death, refer to the information below. For more information, see [www.datastreamserver.com/safety](http://www.datastreamserver.com/safety)**

- Consult all documentation, packaging, and product labelling before use. Note that some products feature documentation available online. It is recommended to print and retain the documentation.
- Before each use, check the product for loose/broken/damaged/missing parts, wear, or leaks (if applicable). Never use a product with loose/broken/damaged/missing parts, wear, or leaks.
- Products must be inspected and serviced (if applicable) by a qualified technician every 6 months. This is based on average residential use by persons of average size and strength, and on a property of average metropolitan size. Use beyond these recommendations may require more frequent inspections/servicing.
- Ensure that all users of the product have completed a suitable industry recognised training course before being allowed access to the product.
- The product has been supplied by a general merchandise retailer that may not be familiar with your specific application or description of application. Be sure to attain third-party approval from a qualified specialist for your application before use, regardless of any assurances from the retailer or its representatives.
- This product is not intended for use where fail-safe operation is required. As with any product (for example, automobile, computer, toaster), there is the possibility of technical issues that may require the repair or replacement of parts, or the product itself. If the possibility of such failure and the associated time it may take to rectify could in any way inconvenience the user, business, or employee, or financially affect the user, business, or employee, then the product is not suitable for your requirements. This product is not intended for use where incorrect operation or a failure of any kind, including but not limited to, a condition requiring product return, replacement, parts replacement, or service by a technician may cause financial loss, loss of employee time or an inconvenience requiring compensation.
- If this product has been purchased in error when considering the information presented here, contact the retailer directly for details of their returns policy, if required.

